

**ESKOM HOLDINGS SOC LIMITED**

**MEDUPI POWER STATION  
NORTHERN ASH & GYPSUM DISPOSAL FACILITY  
CONCEPT DESIGN REPORT**

Report No.: JW158/17/G145 – Rev 1

November 2017





**Jones & Wagener**

Engineering & Environmental Consultants  
Internet presence: [www.jaws.co.za](http://www.jaws.co.za)

## **DOCUMENT APPROVAL RECORD**

Report No.: JW158/17/G145 – Rev 1

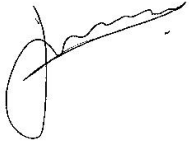
<b>ACTION</b>	<b>FUNCTION</b>	<b>NAME</b>	<b>DATE</b>	<b>SIGNATURE</b>
Prepared	Engineer	Jennifer Sandham Caroline Bladen Silke Louw Aubrey de Beer	2017/10/06	
Reviewed	Project Manager	Charl Cilliers	2017/11/14	
Approved	Technical Director	Michael Palmer Jonathan Shamrock	2017/11/23	

## **RECORD OF REVISIONS AND ISSUES REGISTER**

<b>Date</b>	<b>Revision</b>	<b>Description</b>	<b>Issued to</b>	<b>Issue Format</b>	<b>No. Copies</b>
2017/10/06	A	Draft	DWS	Hard copy	1
2017/11/14	B	Initial draft submission	Eskom	Soft copy (PDF)	1
2017/11/23	0	Final	Eskom	Hard copy & PDF	1
2017/11/30	1	Inclusion of Eskom Comments	Eskom	Hard copy & PDF	1

## SYNOPSIS

The Medupi Power Station is one of two new coal fired power stations being constructed by Eskom to meet the growing power needs of South Africa. An integral part of the power station is the ash disposal facility that will store the residue of the coal combustion process for the life of the power station.

Medupi features new super critical boilers which operate at higher temperatures and pressures than older boilers providing better efficiency. The power station will also incorporate wet limestone flue gas desulphurisation (FGD) technology which will be retrofitted after 6 years of commissioning. The FGD plant will produce gypsum as a by-product which needs to be disposed of in an environmentally sustainable manner.

Previously the ash was considered to be hazardous and thus the 0 to 2 year area was designed according to the Minimum Requirements and a H:h liner system installed. However, regulations have been promulgated by the DEA in terms of NEM:WA on the 23rd August 2013.

The ash and gypsum now classify as Type 3 wastes and require to be disposed of on a Class C lining system. This liner will be implemented at the facility from the 2 to 4 year area onwards. It is proposed that the gypsum from the FGD plant will also be disposed of on the ash facility.

The final landform of the ash and gypsum facility has side slopes at 1:5 slope and a plateau that has a long fall of 1:300. The final height of the facility goes up to 72 m above ground, storing a volume of 193 315 105 m<sup>3</sup> which converts to a total life of 19.2 years. The additional height is necessary to counter the reduction of liner footprint due to the 1000 m buffer of the Sandloop Spruit which is located to the south west of the facility.

A daily water balance was conducted to ensure that the pollution control dams associated with the extension of the facility are adequately sized, to ensure a risk of spill of less than 2% in any given year over the life of the facility. Storm water management is divided into clean and contaminated management and includes berms, geocell lined trenches and the pollution control dams.

On-going rehabilitation occurs behind the advancing face as the facility develops. This ensures only a relatively small window of ash is exposed to the environment. On-going placement of topsoil reduces storm water contamination, dust blow and erosion of the ash.

The conceptual design of all the above mentioned elements are discussed in this report.

# ESKOM HOLDINGS SOC LIMITED

MEDUPI POWER STATION  
NORTHERN ASH & GYPSUM DISPOSAL FACILITY  
CONCEPT DESIGN REPORT

REPORT NO: JW158/17/G145 – Rev 1

<u>CONTENTS</u>	<u>PAGE</u>
1. INTRODUCTION	1
1.1 Background.....	1
1.2 Reference Documents.....	1
1.3 Definitions and abbreviations .....	4
1.4 Terms of Reference.....	5
2. BORROW PIT INVESTIGATION	6
2.1 Site Locality.....	6
2.2 Geology.....	6
2.3 Site Drainage .....	8
2.4 Methodology.....	9
2.5 Site Stratigraphy.....	10
2.6 Laboratory Results .....	11
2.7 Geotechnical Considerations.....	14
2.8 Borrow Pit Quantities.....	15
2.9 Borrow Pit Investigation Conclusion .....	15
3. CONCEPT DESIGN	15
3.1 Geometric design .....	16
3.2 Liner design .....	20
3.3 Interaction of the Northern Ash & Gypsum Disposal Facility and the Excess Coal Stockyard .....	22
3.4 Geomembrane Protection Against Elevated Temperatures .....	23
3.5 Stability Analysis .....	25
4. CONSTRUCTION QUALITY ASSURANCE	29
4.1 Geomembrane .....	29
4.2 Geotextiles .....	29
4.3 BES layers .....	29
4.4 Stone and sand Drainage Layers and Protection Layers .....	29
4.5 HDPE Pipe.....	29
5. DESCRIPTION OF THE BASELINE HYDROLOGY	30
5.1 Regional Climate.....	30
5.2 Catchment and Topography Description .....	30
5.3 Rainfall and Evaporation .....	33
6. WATER BALANCE	37
6.1 Modelling Approach.....	37
6.2 Inputs, Assumptions and Limitations .....	37
6.3 Water balance analysis and results .....	44
6.4 Conclusions and Recommendations .....	53
7. STORM WATER MANAGEMENT PLAN	53
7.1 Storm Water Management Philosophy .....	53
7.2 Storm Water Management Plan Objectives.....	54

7.3	Design Criteria .....	54
7.4	Existing Storm Water Management Infrastructure .....	55
7.5	Proposed Contaminated Storm Water Management System.....	57
7.6	Proposed Clean Storm Water Management System .....	58
7.7	Approach and Methodology.....	60
7.8	Assumptions.....	60
7.9	Catchment Delineation and Characterisation.....	61
7.10	Storm Water Collection and Drainage Infrastructure Sizing .....	62
7.11	Water Quality Management (Desilting).....	73
7.12	Erosion Protection.....	73
7.13	Access to the NAGDF Footprint .....	73
8.	ASH GROWTH PLAN	73
8.1	Assumptions.....	73
8.2	Growth plan.....	74
8.3	Topsoil management.....	78
9.	LIFE CYCLE COST ESTIMATE	78
9.1	Assumptions.....	78
10.	NORTHERN ASH & GYPSUM DISPOSAL FACILITY INFRASTRUCTURE	80
10.1	Material handling.....	80
10.2	Access roads.....	81
10.3	Fencing .....	81
10.4	Perimeter lighting .....	81
10.5	Other infrastructure .....	82
11.	ISSUES TO BE ADDRESSED IN THE DETAILED DESIGN	82

APPENDICES

Appendix A	LABORATORY TEST RESULTS
Appendix B	J&W NOTE: LINER SERVICE LIFE
Appendix C	GROWTH PLAN
Appendix D	LIFE CYCLE COST ESTIMATE
Appendix E	MINUTES FROM DWS MEETING

LIST OF TABLES

Table 2-1: Site Stratigraphy depths within the proposed Borrow Pit.....	10
Table 2-2: Summary of the Laboratory test results .....	11
Table 2-3: Compaction results.....	13
Table 2-4: Summary of the Falling head permeability.....	13
Table 3-1: Capacity of NAGDF alternative geometries .....	18
Table 3-2: Total life of NAGDF alternative geometries.....	18
Table 3-3: Estimated times for three stages of degradation and resulting service lives (Rowe, 2005).....	24
Table 3-4: Material properties used in stability analysis.....	26
Table 3-5: Height increase of NAGDF effect on the conveyor.....	27
Table 3-6: Height increase of NAGDF effect on the number of shifts.....	27
Table 3-7: Financial impact of increase in the number of shifts.....	28

Table 3-8: Height increase of NAGDF effect on dozing costs .....	28
Table 5-1: South African rainfall stations characteristics closest to Medupi NAGDF (Smithers and Schulze, 2002) .....	33
Table 5-2: Design Rainfall Depths for SAWS Station No. 0674429 W, Sterkfontein Station (Smithers and Schulze, 2002) .....	35
Table 6-1: Key data for the Sterkfontein (0674207W) rainfall station .....	38
Table 6-2: Average monthly rainfall and evaporation depths (from WR2012) .....	40
Table 6-3: Runoff factors .....	41
Table 6-4: Existing dam capacities .....	46
Table 6-5: Proposed dam capacities .....	47
Table 6-6: Required dam abstraction rates for dust suppression and irrigation.....	52
Table 6-7: Required dam capacities based on a reduced abstraction rate from the dams .....	52
Table 7-1: Summary of contaminated storm water trenches existing at 0 to 4 year area of the NAGDF.....	55
Table 7-2: Sub-catchment surface characteristics .....	62
Table 7-3: Phased contaminated storm water management works.....	66
Table 8-1: Unit commission dates and associated volumes generated.....	74
Table 8-2: Details of 4 year lined areas .....	77
Table 8-3: Commencement of construction of 4 year lined areas .....	78
Table 9-1: Operational and rehabilitation costs for facility.....	79

## LIST OF FIGURES

Figure 2-1: Site Locality.....	7
Figure 2-2: Regional Geology.....	8
Figure 2-3: Test pit Layout.....	10
Figure 2-4: Site Stratigraphy.....	11
Figure 2-5: Grading Curves, Plasticity & Heaving Chart of the Material Tested .....	12
Figure 3-1: Original NADF geometry .....	16
Figure 3-2: Alternative 1 – extend footprint into north western corner .....	17
Figure 3-3: Original, Alternative 2 & 3 NAGDF geometries considering the 500mm and 1000 mm buffers .....	17
Figure 3-4: New footprint of NAGDF (in 4 year areas) .....	19
Figure 3-5: Final landform of NAGDF (dotted lines indicate shifts).....	19
Figure 3-6: Typical Class C Landfill barrier system.....	20
Figure 3-7: Typical liner detail in NAGDF.....	21
Figure 3-8: Typical liner detail in PCDs.....	22
Figure 3-9: Typical detail for liner tie-in between ECSY and NAGDF (Class C to Class C).....	23
Figure 3-10: Typical layout of temperature monitoring system.....	25
Figure 3-11: Safe Edge Distance.....	27
Figure 5-1: Eskom Medupi ADF in relation to quaternary catchment A42J .....	31
Figure 5-2: Topography and Location of Tributaries Relative to Eskom Medupi ADF .....	32
Figure 5-3: Eskom Medupi ADF in Relation to Mean Annual Precipitation Zones .....	34
Figure 5-4: Eskom Medupi ADF in relation to Mean Annual Evaporation Zones .....	36
Figure 6-1: Daily rainfall record for Sterkfontein (0674207W) rainfall station.....	38
Figure 6-2: Rainfall mass plot for Sterkfontein (0674207W) rainfall station .....	39
Figure 6-3: Monthly rainfall and evaporation for the Medupi NAGDF .....	40
Figure 6-4: Catchment areas for each four year area .....	42
Figure 6-5: Schematic flow diagram for the Medupi NAGDF.....	45
Figure 6-6: Dam D1 dam volume over time plot.....	47
Figure 6-7: Dam D2 dam volume over time plot.....	48
Figure 6-8: Dam D2B dam volume over time plot .....	48
Figure 6-9: Dam D3 extension dam volume over time plot.....	49

Figure 6-10: Dam D3B dam volume over time plot .....	49
Figure 6-11: ECSY PCD D4 dam volume over time plot .....	50
Figure 6-12: ECSY PCD D5 dam volume over time plot .....	50
Figure 6-13: ECSY PCD D6, D7 and D8 dam volume over time plot .....	51
Figure 6-14: ECSY PCD D6 only volume over time plot .....	51
Figure 7-1: Existing Storm Water Management Infrastructure .....	56
Figure 7-2: 4 to 8 Year Storm Water Management Plan .....	70
Figure 7-3: 8 to 12 Year Storm Water Management Plan .....	71
Figure 7-4: 12 to 20 Year Storm Water Management Plan .....	72
Figure 8-1: Growth plan – Time vs. Chainage.....	75
Figure 8-2: Growth plan – Volume vs. Time.....	76
Figure 8-3: Growth plan – Volume vs. Chainage .....	76
Figure 8-4: Topsoil – Resources vs. Requirements .....	78
Figure 9-1: Life cycle cost estimate – Expenditure vs. Time .....	80



# Jones & Wagener

Engineering & Environmental Consultants  
59 Bevan Road PO Box 1434 Rivonia 2128 South Africa  
tel: 00 27 11 519 0200 www.jaws.co.za email: post@jaws.co.za



## ESKOM HOLDINGS SOC LIMITED

MEDUPI POWER STATION  
NORTHERN ASH & GYPSUM DISPOSAL FACILITY  
CONCEPT DESIGN REPORT

REPORT NO: JW158/17/G145 – Rev 1

## 1. INTRODUCTION

### 1.1 Background

Eskom's Medupi Power Station is a six (6) unit dry cooled, coal fired power plant that produces a total of 4 788 MW of energy, and came into operation in 2015. Exxaro's Grootegeluk mine is located within 5 km from Medupi and is likely to supply power station coal to Medupi over its expected 50 year life time.

Medupi features new super critical boilers which operate at higher temperatures and pressures than older boilers providing better efficiency. The power station will also incorporate wet limestone flue gas desulphurisation (FGD) technology which will be retrofitted after 6 years of commissioning. The FGD plant will produce gypsum as a by-product which needs to be disposed of in an environmentally sustainable manner.

Ash is formed from the coal burning process and is transported to the Northern Ash Disposal Facility (NADF) to the west of the Power Station by means of conveyor systems. It is proposed that the gypsum from the FGD plant will also be disposed of on the NADF and therefore will be referred to as the Northern Ash & Gypsum Disposal Facility (NAGDF). The facility forms an integral part of the power station's infrastructure and requires continuous monitoring and management. The operation of the facility involves controlling the geometry of the facility and managing storm water and concurrent rehabilitation on it, while ensuring that adverse effects on the environment are minimised. The NAGDF is currently in its first four years of operation and is a lined waste management facility.

### 1.2 Reference Documents

#### 1.2.1 Provided information

The following information was provided by Eskom and was used to carry out the concept design:

- 84CIVL011-Dirty Water and Clean Water Dams;
- 84CIVL036-Stormwater Design Criteria;
- 240-53113685 Design review procedure;
- 240-57127951 Standard for the execution of site investigations;
- 240-57127955 Geotechnical and foundation engineering standard;
- 240-86973501 Engineering Drawing Standards - Common requirements;
- Surface Water Impact Assessment and Baseline Draft Report for Medupi Power Station. Report number 1415879-310165-2, Golder Associates Africa (Pty) Ltd, 2017.

**JONES & WAGENER (PTY) LTD** REG NO. 1993/002655/07 VAT No. 4410136685

**DIRECTORS:** GR Wardle (Chairman) PrEng MSc(Eng) FSAICE **JP van der Berg (CEO)** PrEng PhD MEng FSAICE **JE Glendinning** PrSciNat MSc(Env Geochem) MSAIEG **M Rust** PrEng PhD MSAICE  
**TM Ramabulana** BA(Social Sciences) **A Oosthuizen (Alternate)** PrEng BEng(Hons) MSAICE  
**TECHNICAL DIRECTORS:** **D Brink** PrEng BEng(Hons) MSAICE **PG Gage** PrEng CEng BSc(Eng) GDE MSAICE A1StructE **JR Shamrock** PrEng MSc(Eng) MSAICE MIWMSA **NJ Vermeulen** PrEng PhD MEng MSAICE  
**HR Aschenborn** PrEng BEng(Hons) MSAICE **M van Zyl** PrSciNat BSc(Hons) MIWMSA **MW Palmer** PrEng MSc(Eng) MSAICE **TG le Roux** PrEng MEng MSAICE **AJ Bain** PrEng BEng MSAICE  
**GB Simpson** PrEng MEng MSAIAE MSAICE **JS Msiza** PrEng BEng(Hons) MSAICE MIWMSA **G Harli** PrEng MEng MSAICE **JS Hex** PrSciNat MSc(Env Man) EAPASA **PJJ Smit** PrEng BEng(Hons) MSAICE  
**ASSOCIATES:** **M van Biljon** PrSciNat MSc(Hydrogeology) **RA Nortjé** PrEng MSc(Eng) MSAICE MIWMSA **C Cilliers** PrEng BEng(Hons) MSAICE **NW Nxumalo** PrEng MSc(Eng) MSAICE  
**J Breyl** PrEng BEng(Hons) MSAICE **F Hoertkorn** PrEng Dr-Ing MSAICE  
**CONSULTANTS:** **PW Day** PrEng DEng HonFSAICE **JA Kempe** PrEng BSc(Eng) GDE MSAICE A1StructE **BR Antrobus** PrSciNat BSc(Hons) MSAIEG **CESA** **ISO9001** **NOSA**  
**FINANCIAL MANAGER:** **CJ Ford** BCompt ACMA CGMA



- Technical memorandum for Medupi FGD Integrated Environmental from Sharon Meyer, Zitholele Consulting dated 19 August 2016 entitled “Information required from Eskom Engineering for purposes of the Integrated Environmental Authorisation Process”
- Waste Classification Methodology and Report: 200-150873\_Zitholele Consulting, Waste assessment of ash and Flue Gas Desulphurisation wastes for the Medupi Power Station
- A Wetland Assessment for the Ash Disposal Facility at Medupi power Station – Lephalele, Limpopo. Report number 2112, Natural Scientific Services CC, 2016.
- Minutes from DWS meeting to discuss Medupi FGD waste disposal: 12949-11-Min-001-DWS disposal meeting-Rev0
- Lidar Survey of the site (December 2009, September 2016 and February 2017)

### 1.2.2 Regulations

The following regulations were referenced during the concept design:

- Best Practice Guidelines for Water Resource Protection in the SA Mining Industry, Series A: Best Practice Guideline A4: Pollution Control Dams, August 2007
- Best Practice Guidelines for Water Resource Protection in the SA Mining Industry, Series G: Best Practice Guideline G1: Storm Water Management, August 2006
- Best Practice Guidelines for Water Resource Protection in the SA Mining Industry, Series G: Best Practice Guideline G2: Water and Salt Balances, August 2006
- Department of Water Affairs and Forestry. 1998. Waste Series. *Minimum Requirements for Waste Disposal by Landfill*. 2nd ed. Formeset Printers, Cape.
- Department: Water Affairs and Forestry. 2007. *Best Practice Guideline A4: Pollution control dams*.
- Department of Water Affairs and Forestry. *Regulations on use of water for mining and related activities aimed at the protection of water resources*. DWAF. Government Notice No. 704, National Water Act, 1998 (Act No. 36 of 1998).
- Department of Water Affairs and Forestry. 1998. National Water Act (No. 36 of 1998).
- Department of Water Affairs. 2012. *Regulations regarding the safety of dams in terms of section 123(1) of the National Water Act, 1998*. Government Notice No. 139, National Water Act of 1998.
- Department of Environmental Affairs. 2013. *National Norms and Standards for the Assessment of Waste for Landfill Disposal*. Government Notice No. R. 635, National Environmental Management: Water Act, 2008 (Act No. 59 of 2008).
- Department of Environmental Affairs. 2013. *National Norms and Standards for Disposal of Waste to Landfill*. Government Notice No. R. 636, National Environmental Management: Water Act, 2008 (Act No. 59 of 2008).
- Government Notice (GN) 704 of 4 June 1999: Regulation on use of water for mining and related activities aimed at the protection of water resources (hereafter referred to as GN704).

- South African National Committee on Large Dams. 1990. *Guidelines for Freeboard for Dams, Safety Evaluation of Dams*. SANCOLD. Report No 3.
- South African National Committee on Large Dams. 2011. *Guidelines on Freeboard for Dams, Safety Evaluation of Dams, Volume 2*. SANCOLD. Report No 1759/2/11.
- South African National Roads Agency Limited. 2007. *Drainage Manual*. 5<sup>th</sup> ed. SANRAL. Pretoria.

### 1.2.3 Design standards and literature

The following design standards and related literature was referenced in the concept design:

- Adamson, P. T. 1981. *Southern African storm rainfall*. Technical Report, TR 102. Department of Water Affairs, Pretoria, South Africa.
- da Silva, T. 2013. *Temperature considerations in geomembrane lined ash deposition facilities*. Landfill 2013.
- Drainage Manual, 5<sup>th</sup> Edition, 2007. South African National Roads Agency Ltd.
- Koerner, R.M. 1998. *Designing with Geosynthetics*. 4th ed. New Jersey: Prentice-Hall, Inc.
- Koerner, G.R. Narejo, D. 2005. *Direct Shear Database of Geosynthetic-to-Geosynthetic and Geosynthetic-to-Soil Interfaces*. Geosynthetic Research Institute. GRI Report 30.
- Needham, A. & Knox, K. 2007. *A review of basal landfill temperatures and their effects on geomembrane liner longevity*, Proceedings of Sardinia 2007, Eleventh International Waste Management and Landfill Symposium, S. Margherita di Pula, Cagliari, Italy.
- Rowe R. Kerry, Quigley R.M., Brachman R.W.I., Booker J.R. 2004. *Barrier Systems for Waste Disposal Facilities*. 2<sup>nd</sup> ed. Spon Press.
- Rowe, R. K. 2005. *Long-term performance of contaminant barrier systems*. 45th Rankine Lecture. Geotechnique 55, No. 9, 631–678.
- Rowe, R., Hoor, A. & Pollard, A. 2010. Numerical examination of a method for reducing the temperature of Municipal Solid Waste Landfill Liners. Journal of Environmental Engineering, 136, pp. 794-803.
- Schmidt, E. J. and Schulze, R. E., 1987. *Flood Volume and Peak Discharge from Small Catchments in Southern Africa, based on the SCS Technique*. WRC Project No. 155, TT 31/87, Water Research Commission, Pretoria, RSA.
- Smithers, J. C. and Schulze, R. E., 2003. *Design Rainfall and Flood Estimation in South Africa*. WRC Report 1060/1/03, Water Research Commission, Pretoria, RSA, 156 pp.

#### 1.2.4 Jones & Wagener reports

The following reports were referenced in the concept design:

- Jones and Wagener. 2008. *Medupi Power Station Ash Dump Geotechnical Investigation*. Jones and Wagener. J&W Report number JW133/08/B729.
- Jones and Wagener note. 2013. Service life of 1.5mm HDPE geomembrane that meets the GRI GM 13 specification

#### 1.3 Definitions and abbreviations

ADF	Ash Disposal Facility
BAR	Basic Assessment Report
BES	Bentonite Enhanced Soil
bgl	Below ground level
CP	Collapse Potential
DEA	Department of Environmental Affairs
DWA	Department of Water Affairs
DWS	Department of Water & Sanitation
EA	Environmental Authorisation
ECSY	Excess Coal Stockyard
EIA	Environmental Impact Assessment
EMPR	Environmental Management Programme Report
FGD	Flue Gas Desulphurisation
FOS	Factor of Safety
GM	Geomembrane
HDPE	High density polyethylene
IECSY	Integrated Excess Coal Stockyard
J&W	Jones & Wagener
LCS	Leachate collection system
MAE	Mean annual evaporation
MAP	Mean annual precipitation
msl	metres above mean sea level
NAGDF	Northern Ash and Gypsum Disposal Facility
NGL	Natural Ground Level
PCD	Pollution Control Dam
PC	Pollution Control
RDD	Recommended Design Discharge
RDF	Recommended Design Flood

SANCOLD	South African National Committee on Large Dams
SED	Safety Evaluation Discharge
SEF	Safety Evaluation Flood
TM	Team Medupi
VWP	Vibrating Wire Piezometers

Asperity Height : The height of individual texture elements on a textured geomembrane.

#### 1.4 Terms of Reference

Jones & Wagener (Pty) Ltd was appointed by Eskom in April 2017 to develop the concept design for the lined northern ash and gypsum facility extension (from the 4 year footprint where only ash was stored to the end of the facility) and PCDs, including storm water management assessment, stability assessment and design authority approval for the disposal facility. This information is required to feed into the EIA and WULA, required for the remaining disposal facility to store gypsum and ash.

The scope of work entails a concept design for the remaining footprint of the Medupi Power Station Northern Ash & Gypsum Disposal Facility and pollution control dams as shown below:

- Borrow Pit Investigation
- Finalise the liner design specification based on review of waste classification;
- Chemical compatibility literature study;
- Assessment of temperature on liner integrity;
- Stability analysis;
- Review the Northern Ash & Gypsum Disposal Facility geometric design (including 2 alternatives and comparison);
- Interaction between the Northern Ash & Gypsum Facility and the excess coal stockyard;
- Finalise the Northern Ash & Gypsum Disposal Facility Stormwater Management Plan and philosophy;
- Review the existing PCD designs, dirty and clean water canals, dams and silt traps location and geometry including dam liner design (including assessment of use as rehabilitation runoff holding dams);
- Finalise new PCD design and rehabilitation storage dams, dirty and clean water canals and silt traps location and geometry including dam liner design;
- Final Northern Ash & Gypsum Disposal Facility main & standby system growth plan;
- Dust suppression – confirm current system is sufficient;
- Northern Ash & Gypsum Disposal Facility infrastructure requirements including material handling, fencing, roads, perimeter lighting and fencing;
- Northern Ash & Gypsum Disposal Facility rehabilitation concept design;
- Preparation of a concept design report,
- Preparation of life cycle cost estimate including post power station operations.

- Works Information including project specifications.
- Construction Quality Assurance Plan.
- Operating & Maintenance Manual revision for the Northern Ash & Gypsum Disposal Facility & civil works.
- Design submissions to Authorities for approval.

## 2. **BORROW PIT INVESTIGATION**

Jones & Wagener conducted a borrow investigation to determine whether there is a sufficient amount of hillwash sand for liner requirements. It is proposed to treat the sands with a 4% to 6% bentonite mix to improve the material permeability. The investigation falls within the footprint of the proposed ash and gypsum disposal facility which is formed from three main development sections: the 4 to 8 year footprint (959 550m<sup>2</sup>), the 8 to 12 year footprint (1 045 892 m<sup>2</sup>) and the 12 to 20 footprint (214 624m<sup>2</sup>) - a total of 222 ha.

Although it is assumed that the Excess Coal Stockyard will be completely lined by the time the NAGDF reaches its footprint, the footprint of the ECSY was considered in the borrow pit investigation to ensure that sufficient quantities are available for its lining. The extent of its footprint that still required lining at the time of the investigation is 968 800m<sup>2</sup>. Similarly, the 2 to 4 year footprint was being constructed at the time and its footprint of 607 500m<sup>2</sup> was included. Therefore, an additional 157 ha was considered. This brought the total to 380 ha which was rounded to 400 ha to material for lining the PCDs.

The conceptual liner system is shown in Figure 3.7. A total of 300mm thickness is required for the bentonite enhanced sand layers. Over a total footprint of 400ha, an estimated 1,2 million m<sup>3</sup> of hillwash is required for the liner design.

### 2.1 **Site Locality**

The site is located west of the Medupi Power Station near Lephalale in the Limpopo Province. The NAGDF, located on the farm Eenzaamheid 687 LQ, is currently in operation and will expand to the west. The locality of the site is indicated in Figure 2-1.

### 2.2 **Geology**

Medupi Power Station is situated in the Limpopo Province and forms part of the Ellisras basin of the Karoo Supergroup. The basin consists of sandstone and siltstone which fall within the Swartrant Formation.

Geologically the region has been subjected to numerous periods of faulting and folding. Two major faults strike through the area, the Eenzaamheid fault and the Daarby fault. The Eenzaamheid fault in particular has resulted in an upliftment of the older (Mokolian Era) Waterberg Group formations to surface. The Eenzaamheid fault is of the normal type with a northward dipping fault plane. Displacement along it in the vicinity of the ash site is about 250 m.

The northern boundary of the ash site is almost defined by the Eenzaamheid fault and the ash site is therefore underlain by the Mogalakwena Formation (Waterberg Group). The Mogalakwena Formation forms part of the Kransberg Subgroup (formally Upper Waterberg) near the top of this succession and consists predominantly of coarse grained sandstones with inter-bedded rounded pebble conglomerate layers and minor basic volcanic rocks near the base of the stratum. The purple and pink ferruginous laminae are characteristic of the Waterberg sandstones and are clearly visible in road cuttings on the

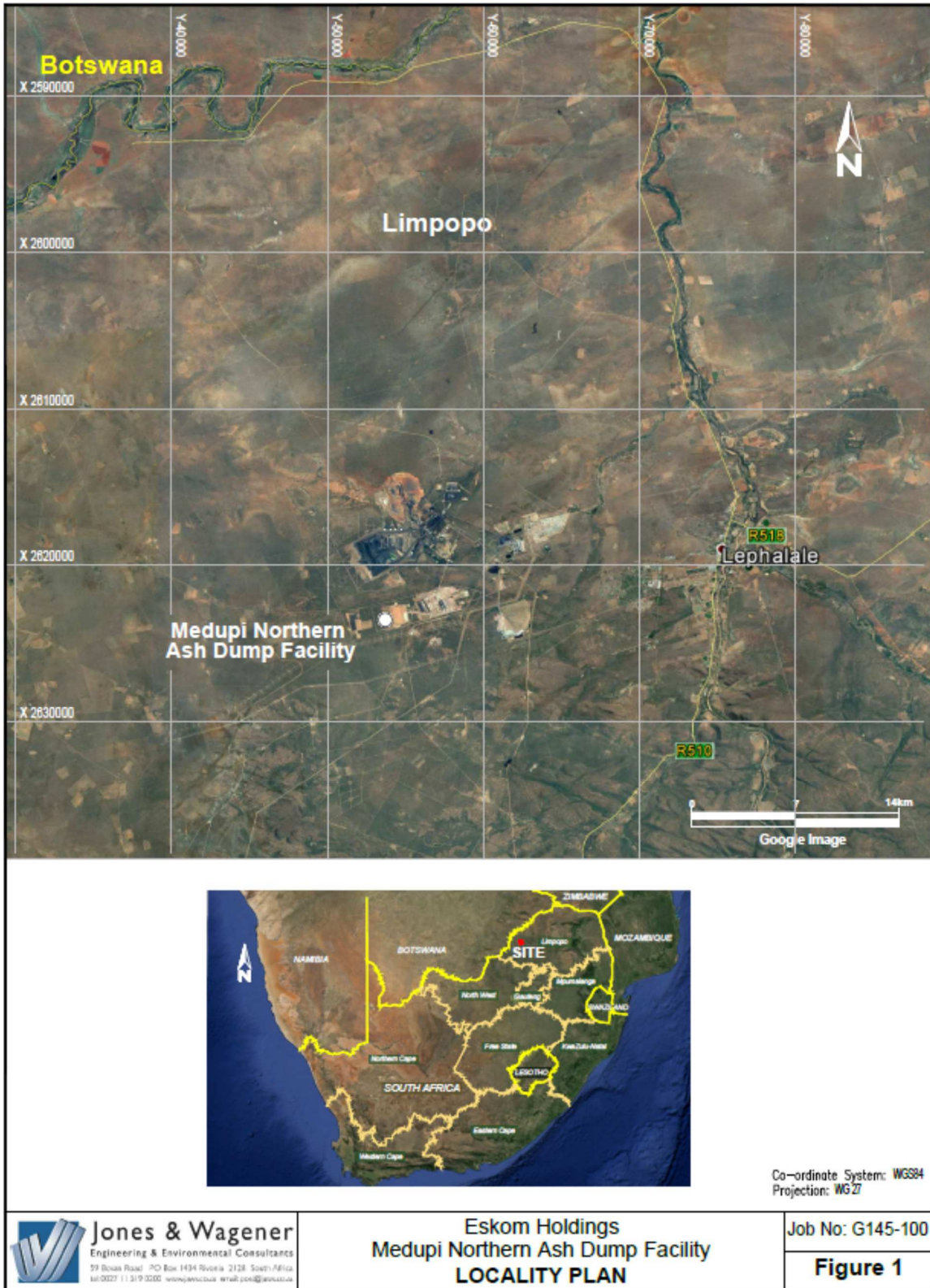

Figure 2-1: Site Locality

R518 from Vaalwater to Lephalale. The Waterberg rocks are extensively intruded by dykes and sills of pre-Karoo diabase with only minor post-Karoo dolerite intrusions.

Bedrock is covered by surficial Quaternary windblown Kalahari sands. These were derived from the arid terrain to the west and have been spread eastwards by interior winds. These aeolian sands can be porous/voided and prone to a collapsible fabric.

Potentially expansive soils may be derived from the weathering of the volcanic intrusions, or as sediment in river and stream courses. The geology of the site is indicated in Figure 2-2.

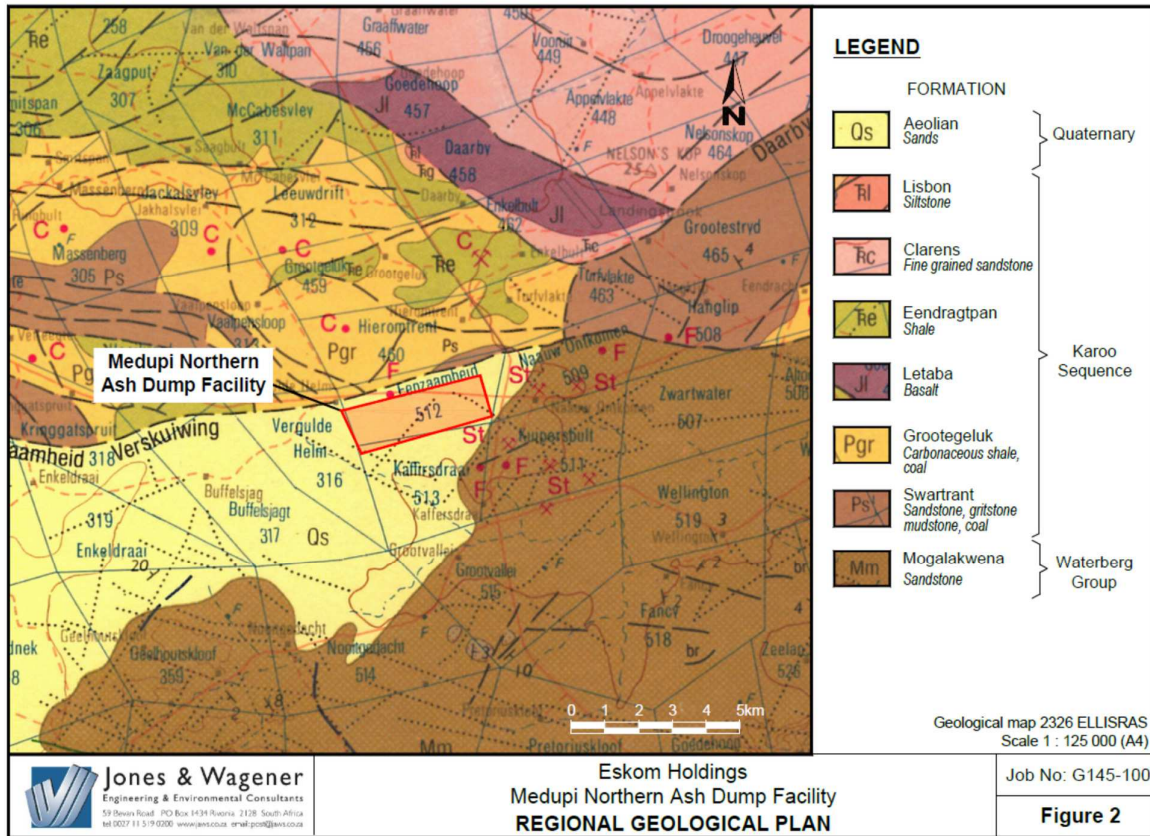

Figure 2-2: Regional Geology

### 2.3 Site Drainage

The site has an ephemeral drainage environment where poorly developed streams flow after heavy rains and periods of flooding. Due to the thick sand cover, most of the water flow occurs below natural ground surface unless in periods of large floods. These streams flow in a dendritic pattern south where they connect to more prominent intermittent streams which eventually drain into the Sandloop River located south of Medupi Power Station. Alluvial deposits have been encountered during the test pitting.

## 2.4 Methodology

### 2.4.1 Desk Study

The desk study entailed a review of existing geotechnical reports conducted within or next to the surrounding disposal facility. A report from Jones & Wagener, number JW133/08/B729 was able to provide the following information:

- 9 test pits excavated in 2008.

### 2.4.2 Site Investigation

The fieldwork was conducted from 25<sup>th</sup> to 27<sup>th</sup> April 2017, assisted by WBHO who provided a New Holland TLB 590B for excavating test pits. The fieldwork entailed the following:

- Excavation of 25 test pits within the proposed borrow pit
- Soil profiling of the various soil horizons encountered
- Sampling of the various soil horizons

The test pit locations are indicated in Figure 2-3.

### 2.4.3 Laboratory Testing

The following soil testing was conducted for the borrow investigations:

- Soil properties which entails
  - Grading analysis
  - Hydrometer tests
  - Atterberg Limits
- Compaction characteristics
  - CBR strength
  - Mod AASHTO
  - Standard proctor tests
- Falling head permeabilities

The laboratory results are attached in Appendix A.



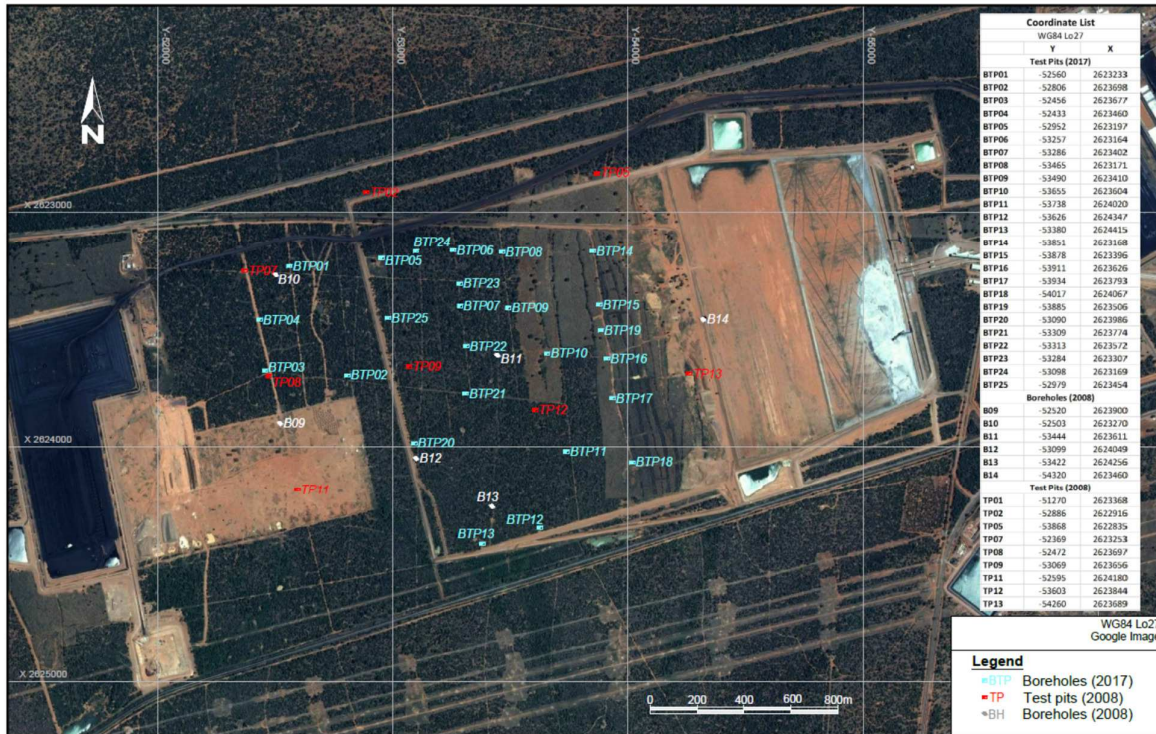

Figure 2-3: Test pit Layout

## 2.5 Site Stratigraphy

The site generally consists of 6 soil horizons. The stratigraphy depths are summarised in Table 2-1 while Figure 2-4 summarises the various horizons.

Table 2-1: Site Stratigraphy depths within the proposed Borrow Pit.

Soil Horizon	Road Fill Layer			Topsoil			Hillwash			Alluvium			Pebble Marker			Residual Sandstone					
	From	To	Thickness	From	To	Thickness	From	To	Thickness	From	To	Thickness	From	To	Thickness	From	To	Thickness			
Total of points out of 33	2			33			33			18			27			7					
Maximum	0.50			0.50			1.30			2.80			2.40			1.80			2.10		
Average	0.30			0.02			0.32			0.31			0.33			1.30			0.97		
Minimum	0.10			0.10			NGL			0.15			0.15			0.10			0.50		
Consistency	Loose to medium dense			Loose			Loose to medium dense			Firm and occasionally stiff			Dense to Very dense			Very dense					
Texture	Silty SAND			Silty SAND			Silty SAND			Sandy SILT to sandy CLAY			Clast supported with silty SAND Matrix and calcareous			silty coarse SAND					
Structure	-			Pinholed			Pinholed			Pinholed			Relatively closely packed gravel								

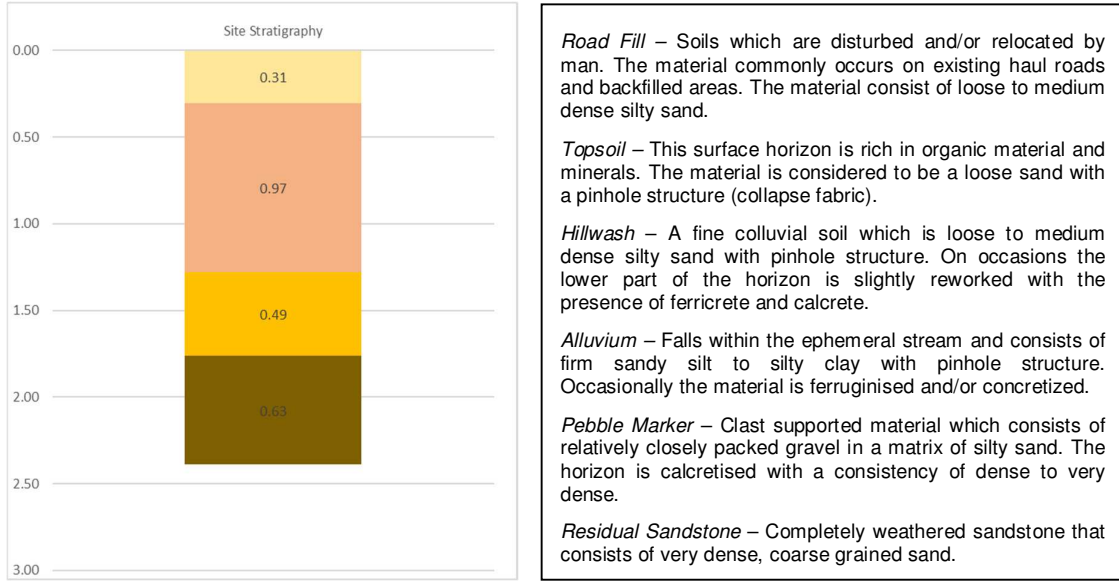

**Figure 2-4: Site Stratigraphy**

## 2.6 Laboratory Results

### 2.6.1 Soil Properties

Representative soil samples were taken from the test pits to determine the geotechnical soil properties of the hillwash and alluvium. Figure 2-5 below summarises the grading, plasticity and heave potential of various horizons.

Table 2-2 below summarises the results of laboratory tests. The results are attached in Appendix A.

**Table 2-2: Summary of the Laboratory test results**

	Hillwash			Alluvium			Stockpile, Coarse ash
	7 test values			2 test values			1 test value
	Minimum	Average	Maximum	Minimum	Average	Maximum	
<b>Grading Analysis</b>							
Grading modulus	1.01	1.13	1.30	0.74		0.95	0.6
% Gravel	1	3	4	2		3	1
% Sand	63	72	79	48		68	62
% Silt	8	10	14	10		14	35
% Clay	9	15	25	16		39	2
% Fines	18	25	34	30		49	37
<b>Atterberg Limits</b>							
LL	21	24	27	29		34	NP
PI	4	9	13	12		16	
<b>Moisture</b>							
NMC	5	8	14	15		17	No Value
<b>Matrix</b>	SAND <sup>(2)</sup> , silty SAND <sup>(3)</sup> to Clayey SAND <sup>(2)</sup>			Silty SAND <sup>(1)</sup> to Sandy Clay <sup>(1)</sup>			Silty SAND <sup>(1)</sup>
<b>Unified</b>	SM <sup>(3)</sup> to SC <sup>(4)</sup>			SC <sup>(1)</sup> to CL <sup>(1)</sup>			ML/OL <sup>(1)</sup>

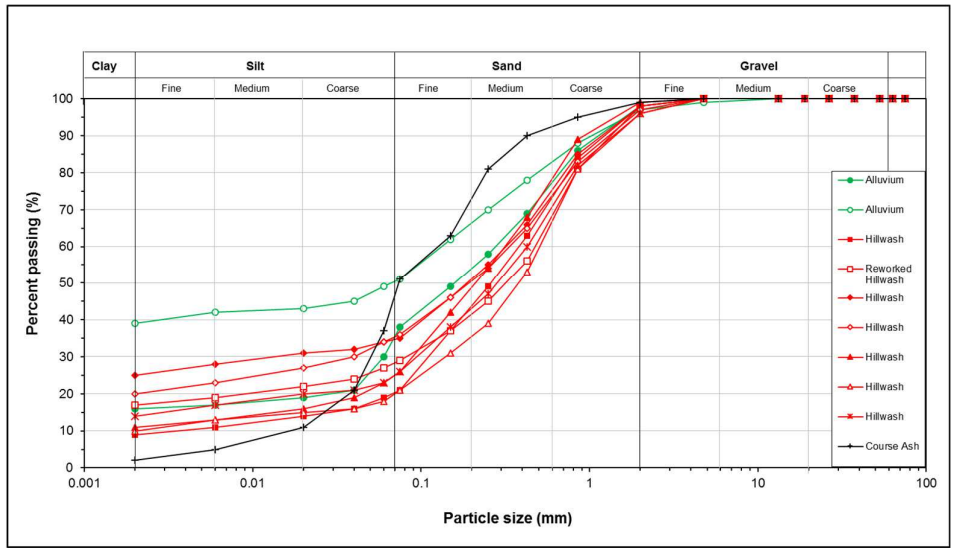

CASAGRANDE CHART

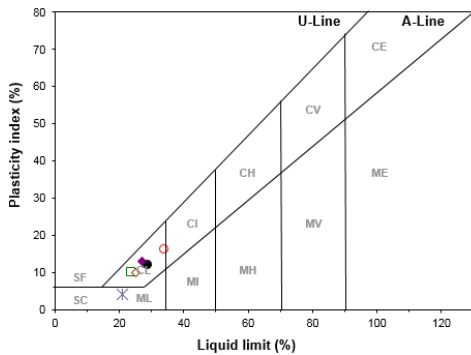

HEAVE CHART

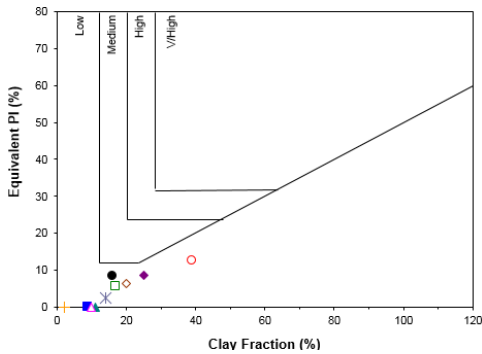

Figure 2-5: Grading Curves, Plasticity & Heaving Chart of the Material Tested

The material has the following characteristics:

**Hillwash:** The material classifies as sandy clay with a high sand content ranging from 63% to 79%. The grading of the material is very uniform across the site and is considered to have low plasticity and heave potential.

**Alluvium:** The material classifies as a sandy clay with a clay content that varies from 16% to 39%. The material is considered to have low heaving potential and plasticity.

**Coarse Ash:** The ash is considered as non-plastic with a high silt and sand content. The material is classified as silty sand. The material has a low plasticity and heaving potential.

### 2.6.2 Compaction Characteristics

Various compaction tests were conducted on the hillwash and coarse ash. Table 2-3 summarises the test results.

The hillwash TRH14 classification range from G7 to G10. The reason for the G7 classification could be a result to the presence of calcrete powder within the hillwash

matrix. However, this material will occur localised in relict stream beds. The predominant hillwash material will likely classify as G10. The maximum dry densities of the material vary from 2073 kg/m<sup>3</sup> to 2165 kg/m<sup>3</sup> with optimum moisture content ranging from 7% to 9%.

The coarse ash sampled from the boiler was tested according to the Mod AASHTO standards and has maximum dry density of 1032 kg/m<sup>3</sup> with an optimum moisture content of 17%. No CBR strength test were conducted on the ash material.

**Table 2-3: Compaction results**

	Hillwash			Stockpile, Coarse ash
	5 test values			1 test value
	Minimum	Average	Maximum	
<b>Densities</b>				
<i>Proctor</i>	2073	2084	2104	No Test
<i>Mod AASHTO</i>	2141	2154	2165	1032
<b>Moisture</b>				
<i>OMC</i>	7	8	9	17
<b>Swell @ 100%</b>	0.00	0.10	0.20	No Test
<b>CBR Strenghts</b>				
95%	12	18	22	No Test
93%	8	12	17	
<b>Classification</b>	G7 to G10			-

#### Permeability

Table 2-4 summarises the laboratory results of the falling head permeability test. The test results are attached in Appendix A.

**Table 2-4: Summary of the Falling head permeability**

Average Falling head permeability (cm/s)	Material Treatment		
	Untreated	4% Bentonite	6% Bentonite
<i>Remoulded to Proctor 98% @OMC +1 - 3%</i>			
	<b>Hillwash</b>		
<i>BTP04</i>	1.40E-05	7.80E-08	3.40E-08
<i>BTP06</i>	1.10E-07		1.60E-08
<i>BTP14</i>	3.40E-07	1.80E-08	
<i>Remoulded to 95% Mod AASHO @OMC +1 - 3% (Material Screened below 4,75mm)</i>			
<i>Coarse Ash</i>	1.90E-04	Not Tested	
<i>Hillwash</i>	2.90E-05		

The falling head tests were conducted under the following instructions:

- Remoulded samples to 98% proctor at 1% to 3% OMC.

- The hillwash exhibited permeabilities from 3,4E-07 cm/s to 1,4E-05 cm/s.
- Hillwash samples remoulded with a 4% to 6% bentonite mix at 98% proctor (1% to 3% OMC).
  - The 4% bentonite mix exhibit permeabilities from 7,8E-08 cm/s to 1,8E-08 cm/s.
  - The 6% bentonite mix exhibit permeabilities from 3,4E-08 cm/s to 1,6E-08 cm/s.
- Two samples were remoulded to a density which was equivalent to the energy exerted by the ash stack. The energy applied during stacking is similar to 95% Mod AASHTO.
  - Coarse Ash exhibited a permeability of 1,9E-04 cm/s.
  - Hillwash has a permeability of 2,9E-05 cm/s.

## 2.7 Geotechnical Considerations

### 2.7.1 Problem Soils

The site consists of silty sand which exhibits pinhole voided structures. This is usually associated with collapse. The collapse fabric is encountered within the topsoil, hillwash and alluvial horizons which extend from natural ground level to a maximum depth of 2,8 m.

No heaving clays or dispersive material has been encountered on site.

### 2.7.2 Excavatability

Soft excavation is expected within the hillwash, alluvium and pebble marker.

Test pits were terminated at depths ranging from 1,4 m to 3,4 m. Slow progressive refusal with the TLB occurred within 15 test pits. The majority of slow excavation was encountered in the dense to very dense pebble marker and residual sandstone. These depths have been recorded ranging from 1,6 m to 2,2 m below ground level.

From past experience the consistency of the residual sandstone is expected to increase with depth. Refusal on soft to medium hard rock were not determined during the investigation.

### 2.7.3 Material Use

The hillwash has high permeability which is not suitable for liner requirements ( $1 \times 10^{-7}$  cm/s). However, when the sands were mixed with 4% to 6% bentonite the permeability of the material increased from  $10^{-5}$  cm/s to  $10^{-8}$  cm/s. Thus treating the sands with bentonite will increase the permeability and make it more suitable for requirements. It is recommended that during construction the material handling be monitored and frequently tested to ensure that the material is compliant with the proposed liner design.

The hillwash classifies as a G10 according to the TRH14 classification and localised pockets of G7 hillwash could occur depending on the degree of calcrete cementation of the material.

From past experiences the hillwash has the capability of providing a good terrace platform. However, great care must be taken on the compaction method practised during construction. It is recommended that the Kalahari sands be compacted using impact rollers.

## 2.8 Borrow Pit Quantities

A total area of 400 ha will be borrowed within the disposal facility. A total volume of 1,2 million m<sup>3</sup> of hillwash sand is required for the liner requirements. These sands will be treated with bentonite to increase the permeability of the material.

The site is covered with an average of 0,9 m of hillwash sands which is overlain by 300 mm of topsoil. A total of 3,8 million m<sup>3</sup> of hillwash is available for borrow and is enough to satisfy the quantity required for the liner requirements.

## 2.9 Borrow Pit Investigation Conclusion

The purpose of the investigation was to determine if there is a sufficient volume of hillwash which could be utilised for liner requirements. The hillwash will be treated with a bentonite mix to increase the material permeability.

The investigation entailed test pitting with a light backhoe (TLB) and soil sampling for laboratory testing.

The material encountered was topsoil (0,3 m thick), hillwash (0,9 m thick), alluvium (0,5 m thick) and pebble marker (0,6 m thick). The TLB progressively refused on dense to very dense pebble marker and residual sandstone.

The hillwash classified as G10 to G7 material according to the TRH14. The G7 material will be encountered in localised pockets along the ephemeral streams on site.

The hillwash has permeability ranging for 10<sup>-5</sup> cm/s to 10<sup>-7</sup> cm/s and is not suitable for liner requirements (1 x 10<sup>-7</sup> cm/s). However, treating the material with a 4% to 6% bentonite mix the material permeability decreases to 10<sup>-8</sup> cm/s which satisfies the liner designs.

An average thickness of 0,9 m of hillwash exist within the proposed facility. A total volume of 3,8 million m<sup>3</sup> of hillwash is available in-situ to be used for liner requirements.

## 3. CONCEPT DESIGN

The following was assessed during the conceptual design stage:

- Review the Northern Ash & Gypsum Disposal Facility geometric design (including alternatives and comparison);
- Finalise the liner design specification based on review of waste classification;
- Chemical compatibility literature study;
- Assessment of liner temperature;
- Stability analysis;
- Interaction between the Northern Ash & Gypsum Disposal Facility and the excess coal stockyard;
- Final Northern Ash & Gypsum Disposal Facility main & standby system growth plan;
- Northern Ash & Gypsum Disposal Facility infrastructure requirements including material handling, fencing, roads, perimeter lighting and fencing;
- Northern Ash & Gypsum Disposal Facility rehabilitation concept design;
- Preparation of life cycle cost estimate including post power station operations.

### 3.1 Geometric design

The aim of the geometric modelling will be to contain 16 years of ash and gypsum capacity at the Northern Ash & Gypsum Disposal Facility in addition to the existing 4 year ash facility. The concept design will be based on 4 year lined phases until the end of the footprint (alternatives to increase the life of the facility are discussed later).

The original concept model for the NADF shows an extension on the western side in the direction of normal operations. The aim is to have both stackers, which are ashing in a western direction, continue to do so. The following restrictions of the stackers and the conveyors will be applicable:

- The shiftable conveyor's tripper car not being able to travel on slopes steeper than 1:10;
- The stackers not being able to travel and simultaneously stack ash and gypsum while on slopes steeper than 1:20;
- The stacker's not being able to travel while shifting on slopes steeper than 1:10.

The current ash geometry can be seen in Figure 3-1. Three alternative geometries were investigated for the NAGDF with the purpose of increasing its capacity. These alternatives are:

1. Extending the existing NAGDF into the north western corner of the facility (see Figure 3-2).
2. Raising the height of the current facility with 10 m.
3. Raising the height of the current facility with 20 m.

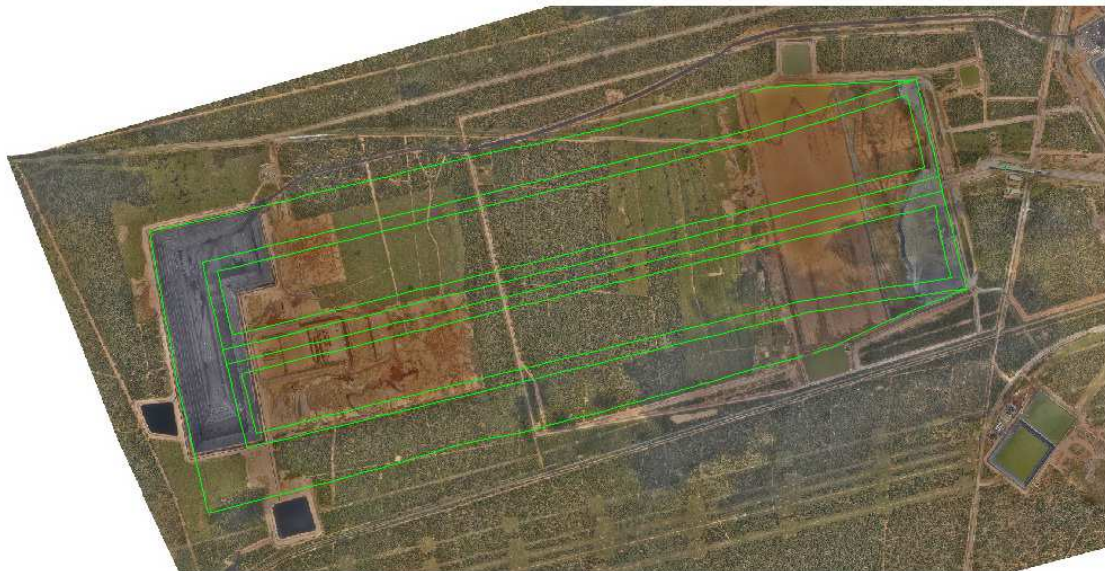

**Figure 3-1: Original NADF geometry**



**Figure 3-2: Alternative 1 – extend footprint into north western corner**

However, environmental specialists' field surveys revealed that a number of small depressions and semi-ephemeral drainage features occur around the NAGDF. Of greatest importance are those wetlands that are situated, and which feed into, the upper reaches of the Sandloop Spruit tributary. It was thus advised that J&W should consider a 500 m and 1000 m buffer to these wetlands in the Sandloop Spruit Tributary.

Figure 3-3 illustrates the impact of the two buffers on the final geometry – the brown line represents the 500 m buffer and the yellow line the 1000 m buffer from the Sandloop. Using the production rate of 136,28 tonnes/hour/unit for ash and 51,33 tonnes/hour/unit for gypsum, the volumes of the various alternatives were calculated and are summarised in Table 3-1. The 2009 survey was used for calculating the volumes as it does not include the coal stockpiles in the ECSY and ash stacks in the 0 to 2 year footprint.

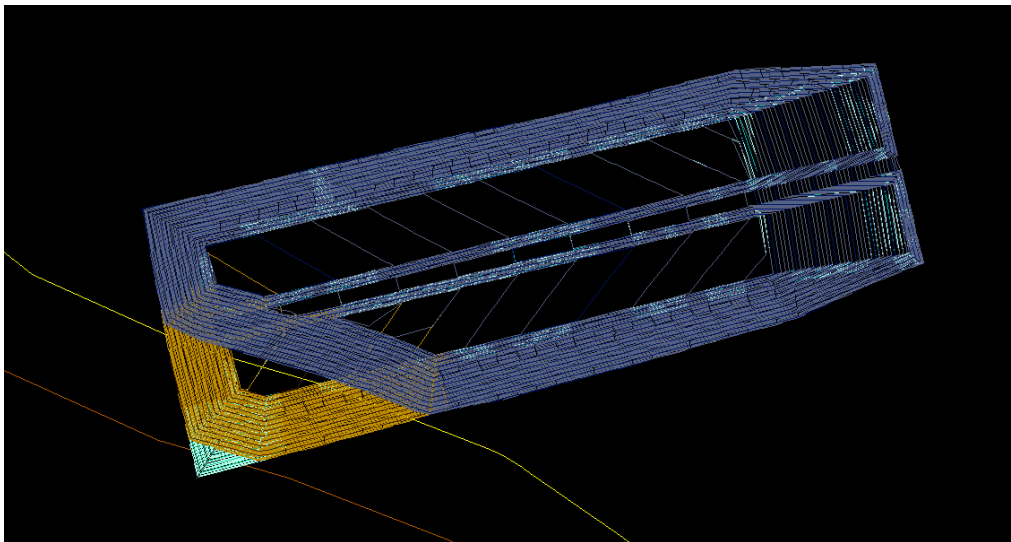

**Figure 3-3: Original, Alternative 2 & 3 NAGDF geometries considering the 500mm and 1000 mm buffers**



**Table 3-1: Capacity of NAGDF alternative geometries**

Design	Total capacity (2009 survey) [m <sup>3</sup> ]		
	No buffer	500 m buffer	1000 m buffer
Original	194 646 495	193 616 621	170 031 857
Alternative 1	224 736 692	223 753 109	196 191 605
Alternative 2	208 364 444	207 439 189	181 859 839
Alternative 3	223 507 084	222 578 354	194 270 178

In Table 3-2, the total life and additional life that will be generated (using the original geometry with no buffer as the comparison base) for each scenario is summarised. The additional life was calculated assuming that the ash deposition rate is 791 452,50 m<sup>3</sup>/month, i.e. including gypsum deposition.

**Table 3-2: Total life of NAGDF alternative geometries**

Design	Total life [y]			Additional life [y]		
	No buffer	500 m buffer	1000 m buffer	No buffer	500 m buffer	1000 m buffer
Original	19.3	19.2	17.1	0.0	-0.1	-2.2
Alternative 1	21.8	21.8	19.3	2.6	2.5	0.1
Alternative 2	20.4	20.3	18.1	1.2	1.1	-1.2
Alternative 3	21.7	21.6	19.2	2.4	2.3	-0.1

Eskom made the decision to stay within the original footprint for the purpose of a waste management license amendment rather than a new license application and to apply the 1 000 m buffer to the Sandloop Spruit Tributary watercourse. Furthermore, the interaction with the ECSY also needed to be considered. Figure 3-4 illustrates the new footprint of the NAGDF – the different coloured blocks are the estimated four year areas and the red line represents the 1 000 m buffer. Note that even though the most southern area of the ECSY overlaps with the 1 000 m buffer, since it is already constructed the impact on the environment has already occurred in this area so there would be no benefit leaving it out of the ash footprint.

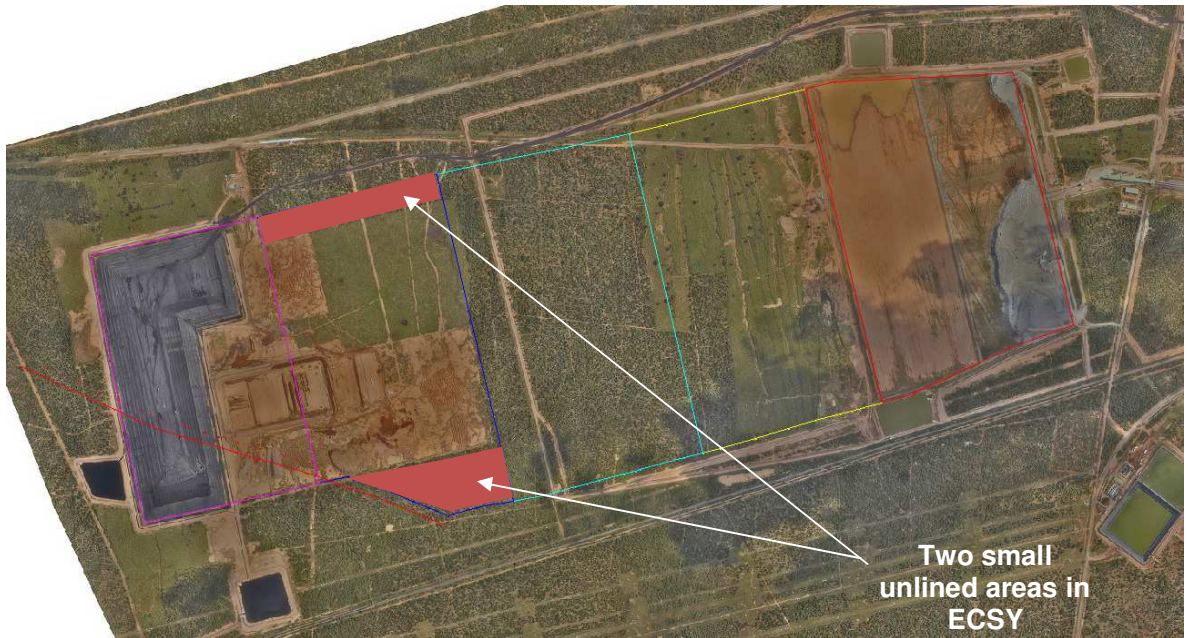

**Figure 3-4: New footprint of NAGDF (in 4 year areas)**

Figure 3-5 illustrates the final landform model which has side slopes at 1:5 slope and a plateau that has a long fall of 1:300. Using this new footprint and the height of 72 m (the height increase of 12m from the original 60m is discussed in Section 3.5.2), the total storage volume comes to 193 315 105 m<sup>3</sup> which converts to a total life of 19.2 years. The original footprint had a total life of 19.3 years.

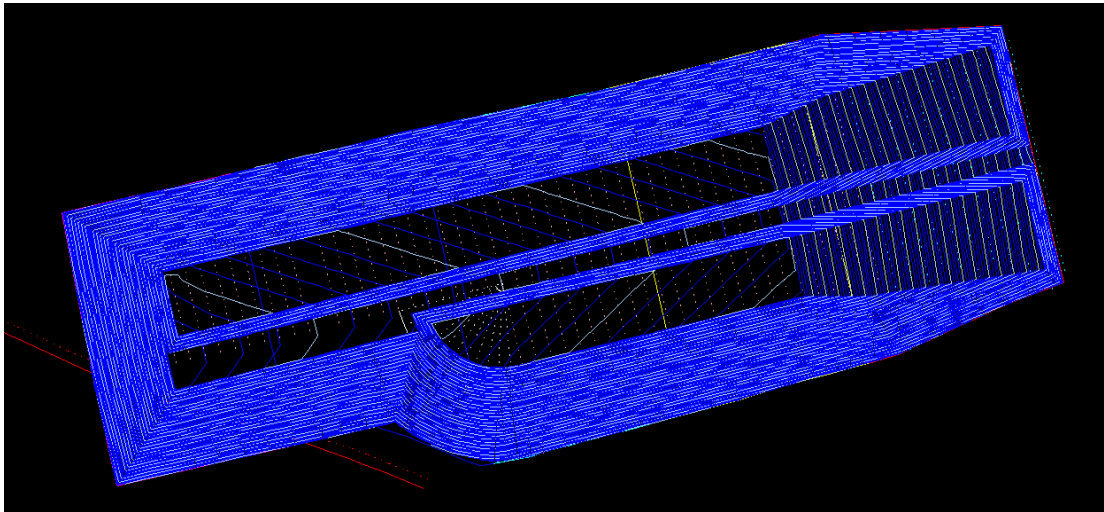

**Figure 3-5: Final landform of NAGDF (dotted lines indicate shifts)**

## 3.2 Liner design

### 3.2.1 Northern Ash & Gypsum Disposal Facility Lining System

The specification of the barrier system is dependent on the waste classification. Regulations have been promulgated by DEA in terms of NEM:WA on the 23rd August 2013, including National Norms and Standards for the Assessment of Waste for Landfill Disposal, Notice No. R. 635, Government Gazette No. 36784, and National Norms and Standards for Disposal of Waste to Landfill, Notice No. R. 636, Government Gazette No. 36784. The ash at Medupi Power Station has been previously classified by Jones & Wagener in January 2015 and is documented in the Waste Classification Methodology and Report: 200-150873. The ash classifies as a Type 3 waste and the proposed gypsum that will be stored has also been classified as a Type 3 waste. Hence, the ash and gypsum can be disposed of together and requires to be disposed of on a Class C lining system.

The aim of the design is to create a barrier from contaminating the surrounding area by means of a composite system of combining bentonite enhanced soil (BES) with a high density polyethylene (HDPE) geomembrane in intimate contact. The intimate contact is to ensure a composite effect which results in a barrier system that is even less permeable than if the two separate elements were to act alone.

Figure 3-6 illustrates the regulatory typical Class C lining system which consists of a 1,5 mm HDPE geomembrane in intimate contact with 2 x 150 mm clay layers that have a maximum permeability of  $1 \times 10^{-7}$  cm/s.

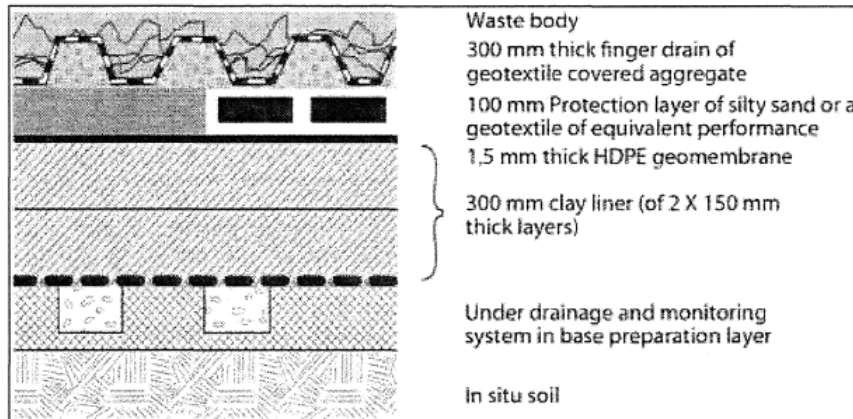

**Figure 3-6: Typical Class C Landfill barrier system**

There is no natural clay available for construction. It has therefore been proposed to use sodium bentonite enriched site sand (BES) in place of natural clay for the compacted clay liner construction. This alternative has been used in the 0 to 4 year area and ECSY. When considering the permeability test results in Section 2.6.2, it is evident that the bentonite enriched site sand will achieve the required permeability of  $1 \times 10^{-7}$  cm/s.

Sodium bentonite has a low permeability when hydrated by deionised water and, hence, dictates the movement of pollutants through the barrier system. However, when exposed to excessive concentrations of divalent cations, such as calcium and magnesium, the monovalent cations, such as sodium and potassium, are replaced by the divalent cations, which greatly increases the permeability of the bentonite.

There is a chance that leachate generated from an ash-gypsum disposal landfill will have an increased risk of affecting the permeability of bentonite due to cation exchange. It is

noted that for the divalent cations to have an impact on the sand bentonite containing layer, there must be defects in the overlying HDPE layer allowing divalent cation containing leachate to seep into the bentonite enhanced site sand layer. It is therefore of utmost importance that the HDPE firstly complies with the required technical performance standards and that, secondly, a high degree of quality control be exercised when the HDPE layer is placed over the bentonite enhanced site sand layer.

Despite the increased risk of an increase in the permeability of the bentonite enhanced site sand layer below the HDPE layer, it is still considered the best option to use a bentonite enhanced site sand layer instead of a Geosynthetic Clay Liner (GCLs). The long-term performance of GCLs are more prone to be significantly impacted by cation exchange due to the limited thickness, while a bentonite enhanced site sand layer of 300 mm will be less prone due to the increased thickness.

The above risks were discussed in the presentation to the Department of Water & Sanitation on 09 October 2017, the minutes of the meeting are attached in Appendix E.

At the 0 to 4 year area and ECSY, a screened insitu hillwash material is used for the leachate collection layer. This would have an effect of increasing hillwash quantities required for the facility by an additional 1.2 million m<sup>3</sup>. While the borrow investigation showed that there is sufficient hillwash material available the coarse ash will be freely available compared to having to excavate the hillwash material. Hence for the 4 to 20 year area of the NAGDF, J&W is suggesting the use of coarse ash as this option has a potential financial savings for Eskom.

Therefore, the final liner at the base of the NAGDF, described from the top of liner to the bottom, consists of:

- Leachate Collection system: Screened coarse ash (<5 mm particle size) of 300 mm thickness with a dual function of protection and drainage. Leachate is drained through a network of perforated HDPE pipes with a filter system from the coarse ash to the pipes is in the following order: site sand, 6 mm filter stone, 13 mm stone and covered with separation geotextile;
- Primary Composite barrier: 1,5 mm double textured HDPE Geomembrane in intimate contact with 2 x 150 mm compacted layers of site sand blended with 5% bentonite by mass.
- In situ preparation by ripping and recompacting the base with under drainage in the form of a HDPE pipe drainage network enclosed by 13 mm stone and wrapped in separation geotextile.

Figure 3-7 below illustrates the layers formerly discussed.

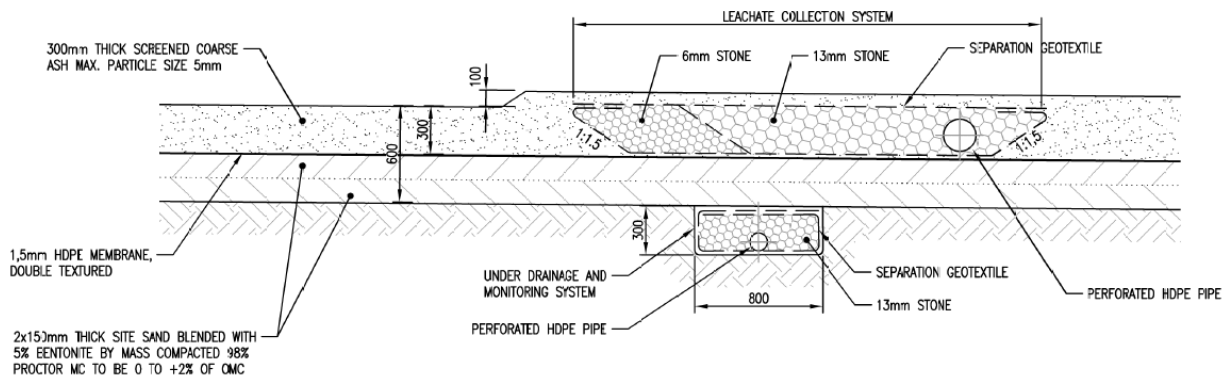

**Figure 3-7: Typical liner detail in NAGDF**

It is important to prevent phreatic head build up on the liner system as this affects the rate of possible through flow of contaminants as well as the stability of the site. The rate of seepage through a barrier increases as the hydraulic head on the barrier increases. Thus, it requires a drainage medium with a hydraulic conductivity (permeability) that will effectively drain away any liquid.

A sample of coarse ash was obtained directly from the boiler and sent for testing to determine its permeability properties. The sample was remoulded to a density which was equivalent to the energy exerted by the ash stack which is similar to 95% Mod AASHTO. When considering the permeability test results in Section 2.6.2, the coarse ash has a permeability of  $1,9 \times 10^{-4}$  cm/s while the hillwash material has a permeability of  $2,9 \times 10^{-5}$  cm/s. Comparing these two values it is clear that there is an order of magnitude difference and hence the coarse ash material has been proposed as it classifies as a better drainage medium.

### 3.2.2 Pollution Control Dams Lining System

The PC dams are lined as follows from the top to the basal earthworks level:

- Ballast Layer: 250 mm thick layer of screened coarse ash (<5 mm particle size) stabilised with cement to attain a minimum strength of 2 MPa.
- Primary Composite barrier: 1,5 mm double textured HDPE Geomembrane in intimate contact with 2 x 150 mm compacted layers of site sand blended with 5% bentonite by mass.
- In situ preparation by ripping and recompacting the base with under drainage in the form of a HDPE pipe drainage network enclosed by 13 mm stone and wrapped in separation geotextile.

Figure 3-8 below illustrates the layers formerly discussed.

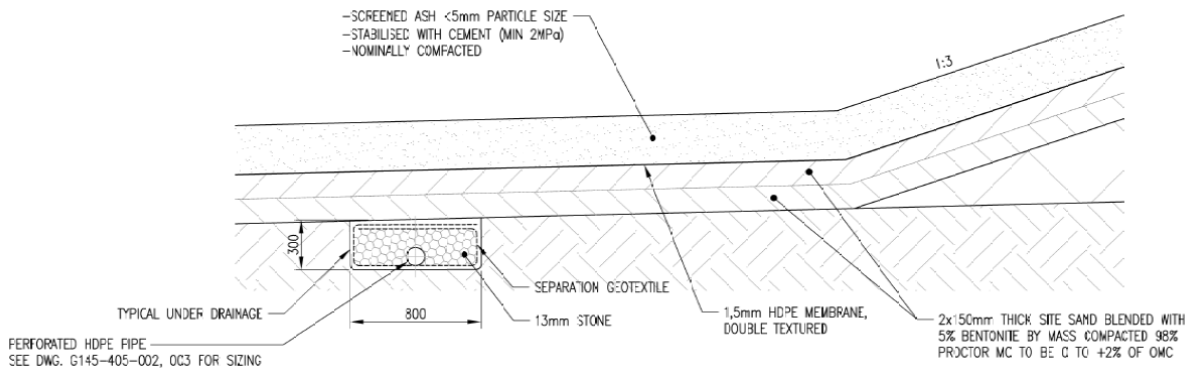
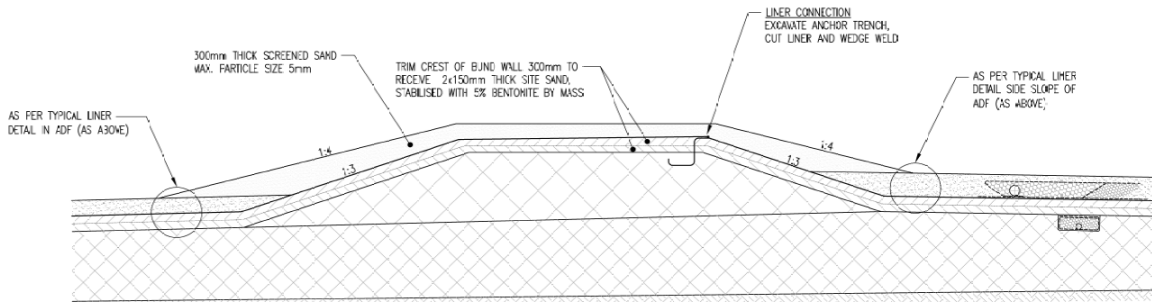

**Figure 3-8: Typical liner detail in PCDs**

### 3.3 Interaction of the Northern Ash & Gypsum Disposal Facility and the Excess Coal Stockyard

The ECSY currently consists of three phases and is located within the footprint of the last eight years of the facility (from 12 to 20 years). It was communicated that the coal will be consumed by the Power Station by the time the facility reaches this position in a letter

from the Medupi Power Station General Manager – for more detail see Section 8.2. The existing ECSY liner system is closely based on the 0 to 2 year ash facility which has a H:h liner system (as per Minimum Requirements) due to the regulations that were applicable at that time. However, since the promulgation of the Norms and Standards both liner designs are currently being changed to a Class C liner hence no liner upgrades will be required at the interface between the NAGDF and the ECSY when the 8 to 12 year area is constructed. Furthermore, it is assumed that entire ECSY area will be available for placement of the ash and gypsum. A typical section of the liner tie-in can be seen in Figure 3-9.



**Figure 3-9: Typical detail for liner tie-in between ECSY and NAGDF (Class C to Class C)**

It is assumed that the full extent of the ECSY will be required and that the gaps between Phases 1, 2 and 3 will be lined to create one uniform lined area. This will occur before the ash reaches the 12 year interface.

On the eastern edge of the ECSY, there is infrastructure that will need to be demolished – the access road, paddock berm and pump sumps. A new HDPE pipe will be installed that will connect all the outlets of these pump sumps and will drain to one of the dams on the southern side of the ECSY. A new HDPE pipe will also be installed in the effluent trench that will tie into the exiting outlet pipes with tee pieces and be backfilled to receive liner above the trench. These details can be seen on drawing G145-405-008.

The extent of the liner in the 12 to 20 year area will be limited to the position of the liner on ECSY Phase 1, 2 and 3 on the northern, western and southern outer berms respectively. However, as per Figure 3-4 there will be two new areas to be lined on the south east corner and northern portion of ECSY Phase 3 and the extend of liner will be along these new outer berms.

### 3.4 Geomembrane Protection Against Elevated Temperatures

Rowe (2005) discussed the effects of temperature on a geomembrane's service life. In the manufacturing process of geomembranes, antioxidants are added to the material to act as the sacrificial component in terms of oxidation. This means that for a certain time period the antioxidants prevent the geomembrane from getting oxidised, which has the result of increasing the material's durability and service life. The time required to deplete the antioxidants in the geomembrane depended on its exposure rate. In Appendix B a note has been included which details the three stages of degradation and the service life of 1,5 mm HDPE geomembrane that meets the GRI GM13 specification. The results in Table 3-3 show a clear indication of the effect of temperature on the service life of an HDPE geomembrane. The estimated service life of a geomembrane is 190 years at 35 °C and decreases to 20 years at a temperature of 60 °C. Considering Table 3-3, the unadjusted service life predictions are relevant to the NAGDF because there is a low leachate

generating potential. It is important to note that the above antioxidant depletion times and service lives were calculated assuming a constant temperature throughout the entire life. However, temperature of the liner is likely to vary with time.

**Table 3-3: Estimated times for three stages of degradation and resulting service lives (Rowe, 2005)**

(1) Temp: °C	(2) Stage 1: years Simulated,* $t_{siml}$	(3) Stage 2: years Base,† $t_V$	(4) Stage 2: years Adjusted,‡ $t_{Va}$	(5) Stage 3: years Base,§ $t_B$	(6) Stage 3: years Adjusted,¶ $t_{Ba}$	(7) Service life: years Unadjusted,** $t_{SL}$	(8) Service life: years Adjusted,†† $t_{SLa}$
10	280	50	30	2445	1380	2775	1690
20	115	15	10	765	440	900	565
30	50	6	4	260	150	315	205
35	35	4	2	155	90	190	130
40	25	2	1	95	55	120	80
50	10	1	0.6	35	20	50	35
60	6	0.4	0.3	15	9	20	15

\*Based on simulated liner antioxidant depletion tests (Table 5).

†Calculated using data from Viebke *et al.* (1994) for 2.1 mm wall thickness pipe with water inside and air outside.

‡As per previous note, but adjusted for possible effect of leachate using equation (35) and data from Table 5.

§Calculated using activation energy from Viebke *et al.* (1994) for 2.1 mm wall thickness pipe with water inside and air outside and half-life of 90 days at 115°C from Bonaparte *et al.* (2002).

¶As per previous note, but adjusted for possible effect of leachate using equation (36) and data from Table 5.

\*\* $t_{SL} = t_{siml} + t_V + t_B$ .

†† $t_{SLa} = t_{siml} + t_{Va} + t_{Ba}$ .

A thermal investigation was carried out by Jeffares and Green at the existing Matimba ADF (Geotechnical assessment and thermal investigation at the Matimba Power Station Ash Disposal Facility, Lephalale, Limpopo Province, 2015). The maximum recorded temperature occurred at the basal lining system reaching a temperature of 48 °C. It is estimated that a maximum temperature of 50 °C will be reached in the first year after ash placement, after which point it is expected that temperatures will reduce to the region of 30 to 40 °C.

It is expected that the temperature measurements obtained at Matimba ADF are representative of the conditions at Medupi's NAGDF and hence a conservative effective service life of geosynthetic components at 40 °C is predicted to be 120 years. To confirm this, it is recommended that a temperature monitoring system be installed when the next 2 year area is constructed (4 to 6 year). This will enable 4 years of temperature monitoring to have taken place and thus an informed decision can be made whether to continue the installation of the temperature monitoring system every 2 years or at another specified time interval.

Although thermocouples have predominantly been used in the field of temperature monitoring, J&W is recommending the use of the vibrating wire piezometers (VWP). This instrument is more robust and measures temperature with higher accuracy and has the added benefit of measuring pore water pressures. Needham and Knox (2007) used VWP to measure the temperature of the basal liner of a municipal solid waste landfill in the UK. The VWP was fitted with a NTC type thermistor with an accuracy of  $\pm 0.5^\circ\text{C}$ .

It is suggested that four VWPs be installed and these should be placed directly on top of the liner in the screened coarse ash leachate collection layer. Their location should be close to the facility's centre so that the maximum effect of the ash and gypsum (height of 72 m) deposited over the VWPs can be measured. These VWPs should also be equidistant from the main leachate collection pipe and the herringbone drains to ensure that the atmospheric temperature in the pipes do not influence the temperature reading on the liner. This is illustrated in Figure 3-10 below.

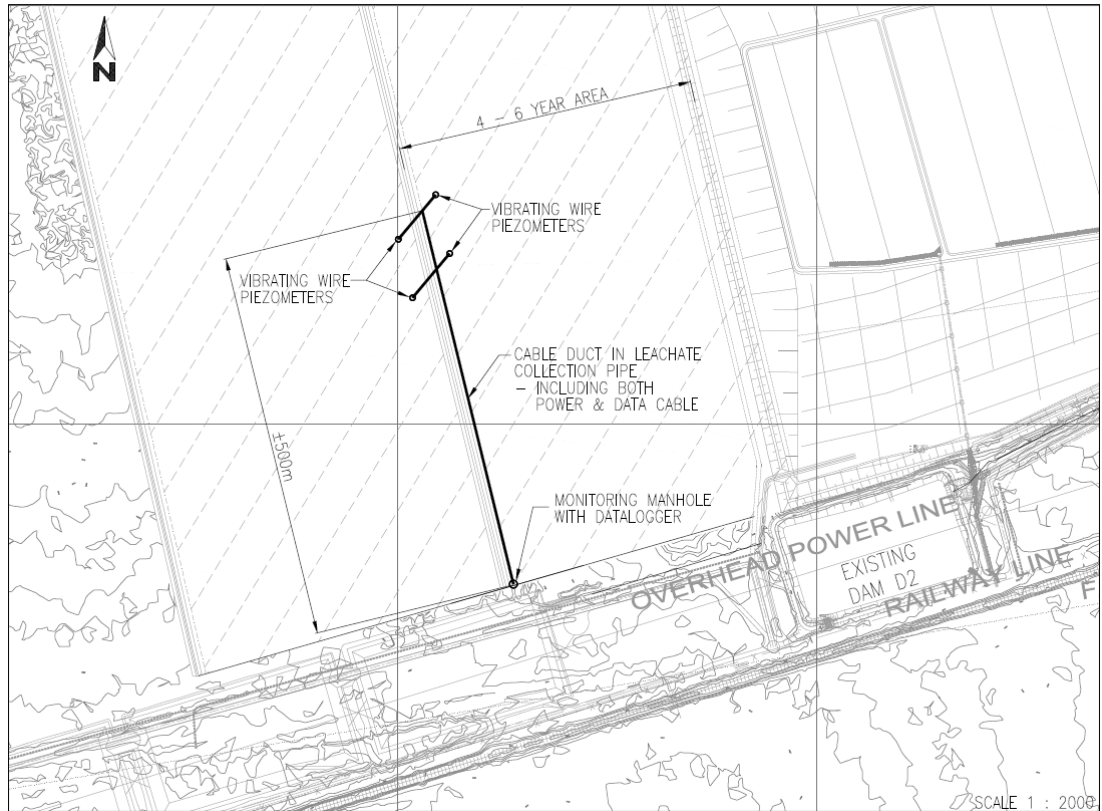

**Figure 3-10: Typical layout of temperature monitoring system**

The VWP should be connected to a datalogger via a cable where the excitation supply cable is separate from the signal cable. J&W suggests the use of Lapp 4 Core Polyvinyl Chloride PVC Sheath Actuator/Sensor Cable, as it is one cable with all four cables individually insulated. The recommended datalogger is a 5 channel instrument from Worldensing which is a wireless data acquisition system for sensor networks based on radio communications. The wireless network is powered by batteries and has a long range providing the means to automatically collect data from the VWPs. This datalogger will be kept secure in a monitoring manhole, which will be constructed in the edge berm, with a lockable manhole cover.

An alternative to using VWPs could be using fibre optic cable where the cable acts as the sensor to thermal activity. In order for this alternative to be cost effective, it would need to be linked to a service provider that would have the instrumentation (DTS box) to take readings from the fibre optic cable.

### 3.5 Stability Analysis

Global slope stability calculations assess the stability of the slope under gravitational and seepage forces. The calculation should consider the critical failure surface where sliding/movement is most likely to occur. In the base of the NAGDF, the upper portion of the lining system consists of a geomembrane underlain by bentonite enhanced soil.

The Geo Studio SLOPE/W stability analysis computer program was utilised to carried out limit equilibrium numerical analysis using the Morgenstern-Price method. The analyses were performed and the factors of safety against failure calculated. The factor of safety is defined as the ratio of stabilizing forces to destabilizing forces.



The stability analysis was carried out with the aim of finding the maximum allowable height of the facility extension above the liner while ensuring that the factor of safety against instability is achieved.

### 3.5.1 Material parameters

Table 3-4 below gives the material parameters used in the software that were determined from previous geotechnical investigations.

**Table 3-4: Material properties used in stability analysis**

Material Properties Used				
Material	Unit Weight (kN/m <sup>3</sup> )	Cohesion (kPa)	Friction angle (degrees)	Source
Medupi Ash	10.8	0	34	J&W Lab Testing
Material under geomembrane	Impenetrable			
Double-textured HDPE geomembrane/bentonite enhanced site sand interface	9.143	Shear stress-displacement curve		TRI Lab testing (residual strengths)

These values were obtained by lab testing of the bentonite enhanced site sand and geomembrane interface with the resultant shear stress-displacement curve being selected to describe the shear strength parameters.

### 3.5.2 Analysis and Results

Since the fine ash and gypsum is placed by means of the stacker, the side slopes form at their natural angle of repose. From laboratory testing at Matimba Power Station and a Gypsum sample sourced internationally by Eskom, it has been established that this angle is 34° and hence the cross sections were drawn at this angle. The cross sections analysed includes the original height of 60 m as well as the increased height of 70 and 80 m. It was assumed that there is water present in the fine ash body to an arbitrary height.

The results showed that due to the fine ash being placed at its natural angle of repose, the Factor of Safety (FoS) is 1 regardless of how high the fine ash is placed. The slip circles occur within the fine ash side slope and not through the geomembrane/bentonite enhanced site sand interface. Therefore, it became evident that the slope stability is not governed by a global failure but rather by a specified Safe Edge Distance (SED).

**As the ash is theoretically placed at an angle of repose, the SED is defined as distance between the constructed crest and a crest that would occur if a slip were to take place creating an angle that results in a factor of safety (FOS) of 1.3 – see**

Figure 3-11.

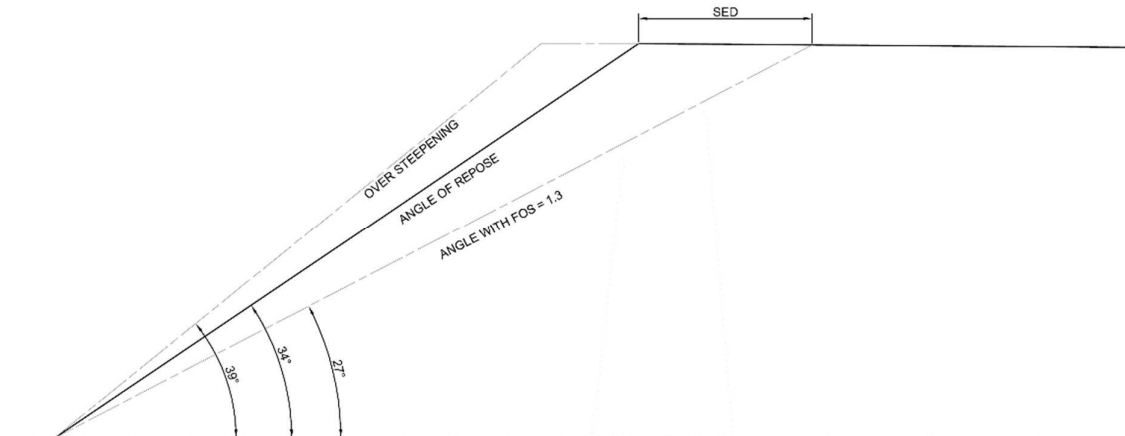

**Figure 3-11: Safe Edge Distance**

J&W took measurements from the February 2017 survey of current ash placed by dozers which was in an oversteepened state (39°) resulting in a greater SED being required. However, it is assumed that once the ash is being placed by the stackers, the angle would resume to the angle of repose (34°). The effect that raising the height has on the facility is that the SED increases as the height increases. To ensure that the stackers and shiftable conveyors are not placed at risk, as the SED increases, the shift width decreases at the same rate. The result of a 10m and 20m increase in height has been summarised in the Table 3-5 and Table 3-6 below. In addition, the details of a 12m increase are shown as this is the final height increase.

**Table 3-5: Height increase of NAGDF effect on the conveyor**

Height increase (m)	Shortening of Shiftable Conveyor		
	Shortening of Conveyor (m)	Conveyor Length (m)	% Shorter
0	0	465.3	
10	32.5	432.8	7%
12	39	426.3	8%
20	65	400.3	14%

**Table 3-6: Height increase of NAGDF effect on the number of shifts**

Height increase (m)	Increase of SED					
	SED req. FOS 1.3 (m)	SED possible (m)	Resulting shift width (m)	Back Stack Width Efficiency	Number of Shifts	% Additional
0	21.6	22.5	66	100%	55	100%
10	26.1	28.5	60	90%	60	111%
12	27	28.5	60	90%	60	111%

20	30.6	34.5	54	79%	67	122%
----	------	------	----	-----	----	------

Table 3-5 also indicates the shortening of the shiftable conveyor that will be required if the height increases. The shortening ranges from 7 to 14% from a height increase of 10 m to 20 m.

If the NAGDF is raised by 10 m, the SED increases to 26,1 m. The concept design is based on the shift width being limited to 6 m intervals due to the extendable conveyor module length. Therefore the next available shift width is 60 m which results in a SED of 28,5 m. However, this 6m restriction is not necessary as the extendable modules can be modified and further optimisation can take place during detail design stage.

This would however make the back-stacking operation 90% efficient as the boom conveyor is not required to slew as much as in the original geometry. This will also result in 5 more shifts overall and will also decrease the amount of time between shifts. In Table 3-7 the financial implication of increasing the number of shifts is summarised.

**Table 3-7: Financial impact of increase in the number of shifts**

		Shift width		
		66 m	60 m	54 m
Number of original shifts		55		
Number of shifts		55	60	66
Number of additional shifts		0	5	11
Average duration between shifts (4-20yr) - Months		4.36	3.96	3.57
Costs of additional shifts		2017		
Cost per shift	Parallel	R 844,739.48	R -	R 4 223 697.40
	Radial	R 591,317.64		R 9 292 134.27

As suggested by Eskom, J&W considered the additional dozing costs that would accompany an increase in height. Table 3-8 presents a summary of the cost and percentage increase in cost for different increases in height.

**Table 3-8: Height increase of NAGDF effect on dozing costs**

Height Increase (m)	Total Height (m)	Total Dozing (length = 2850m), 2 sides Volume (m <sup>3</sup> )	Dozing Costs @ R5.67/m <sup>3</sup>	% of total
0	60	5 745 600	R 32 577 552	
6	66	10 862 775	R 61 591 934	189%
10	70	12 239 325	R 69 396 973	213%
12	72	12 927 600	R 73 299 492	225%
18	78	15 171 975	R 86 025 098	264%
20	80	15 979 950	R 90 606 317	278%

Considering all of the above, it was decided to go with a 12 m height increase. This height increase results in 60 m shift widths and loss of back stack efficiency of 10%. This results in total of 59 shifts required and reduces shift duration from 4,4 months to 4,0 months. Furthermore, additional dozing will be required and the shiftable conveyors will need to be shortened.

#### 4. **CONSTRUCTION QUALITY ASSURANCE**

All construction work to be undertaken will comply with the specifications and will be verified by full time construction supervision by the site monitoring team.

##### 4.1 **Geomembrane**

For the geomembrane, data sheets and conformance tests results from the factory, in compliance with the specifications (GRI GM13) with the following deviations are required:

- Thickness, to be nominal, not -5%, and lowest individual for any of the 10 values is to be -10% as per ASTM D5994
- Minimum Asperity Height 0.9mm as per ASTM D7466 unless otherwise shown on the drawings. If a lower asperity height is offered as an alternative, it may be accepted if laboratory testing is submitted at tender stage to show compliance to the performance specification set out in the specifications.
- Texturing is to be embossed unless otherwise shown on the drawings
- Break elongation to be minimum 250% as per ASTM D6693 Type IV
- Puncture resistance to be minimum 450 N for 1.5mm as per ASTM D4833
- Oven aging requirements to be met for OIT and HP OIT following oven aging

Third Party independent conformance testing to be conducted from samples randomly selected by the resident engineer when the material is delivered to site.

Visual inspections of the liner will be conducted during the installation (and covering with the screened coarse ash), as well as observation of the liner installation, welding and testing. A review of the method statements prior to installation starting will be conducted. A QAC data-pack for the completed installation will be compiled including detailing the panel placement information, tests on trial seams, non-destructive air pressure tests on seams, destructive tests, repair reports and surface approvals. All geomembrane installation is to conform to SANS 10409.

##### 4.2 **Geotextiles**

Polyester geotextiles are not permitted for use due to the high pH environment in which the material will be installed. The geotextiles shall be a non-woven, needle-punched, staple fibre or continuous filament, polypropylene or polyethylene, which complies with the specifications as set out in GRI-GT13 Class 2 (moderate survivability) for separation geotextiles and GRI-GT12a for protection geotextiles.

##### 4.3 **BES layers**

The bentonite shall be approved prior to mixing with the site sand (Hillwash). The blending ratio shall be reviewed. Samples shall be taken during placement for permeability tests. During placement, the thickness, moisture and compacted density shall be verified.

##### 4.4 **Stone and sand Drainage Layers and Protection Layers**

Grading results for the 13mm and filter stone shall be verified. The coarse ash will be sampled and sent for permeability tests. Thickness will be confirmed by survey as the material is placed.

##### 4.5 **HDPE Pipe**

The HDPE pipe quality assurance approval will include a review of the virgin material used to manufacture the pipes, ensuring that the pipe is manufactured from this resin and

a review of the delivery notes and pipe batch numbers on site to ensure that the material data sheets received are for the material delivered to site, as per SANS 4427. The installation approval will consist of a review of the welding report, and pressure testing of solid outlet pipes, as per ISO 21307 and SANS 10268.

## **5. DESCRIPTION OF THE BASELINE HYDROLOGY**

### **5.1 Regional Climate**

The Medupi Power Station is located inside the bushveld climate zone which is classified as a hot, arid climate with mid-summer rainfall. Average maximum temperatures range from 32 °C in January to 23.2 °C in July. On average, there will be 13 days a year where the rainfall will exceed 10 mm depth with the occurrence of hail storms on 2 to 3 days per year. Severe drought conditions have existed in the region 12% of all recorded years. This information is retrieved from the Grootegeluk weather station (0674100). Missing information from Grootegeluk is retrieved from the Ellisras weather station (0674311).

### **5.2 Catchment and Topography Description**

The Medupi Power Station (PS) is situated within the Limpopo Water Management Area and within quaternary subcatchment A42J, of the Mokolo catchment, approximately 22 km from the town of Lephale. The site location relative to the surrounding quaternary sub-catchments is shown in Figure 5-1.

The Sandloop River originates 5 km west of the Medupi NAGDF, and runs from west to east to the south of the NAGDF. It then turns to the north and continues to flow in a north-easterly direction until it enters the Mokolo River, approximately 38 km from its origin. The Mokolo River in turn feeds into the Limpopo River a further 40 km downstream, to the north. Wetlands and minor tributaries have been identified along the Sandloop river. A 1000 m buffer to wetland boundaries has been delineated, (A Wetland Assessment for the Ash Disposal Facility at Medupi power Station – Lephale, Limpopo. Report number 2112, Natural Scientific Services CC, 2016), and the NAGDF operations and storm water management plan (SWMP) will be designed to fall outside of this buffer.

The site has gentle, hilly topography. A ridge with a maximum elevation of 918 msl extends along the northern boundary of the site. The effect of this feature is that there is negligible contributing surface catchment beyond the north of the site. On the eastern side of the ridge is a gradual conical hill which causes drainage to spread in all directions. Otherwise, the drainage is predominantly in a southerly direction at an average slope of 1:100 towards the Sandloop Spruit. There is a low point at the centre of the site, along the southern boundary, and a second low point to the south-west, both with a minimum elevation of 904 msl. Parallel to the site boundary is a railway line, on an embankment at an approximate elevation of 911 msl, cutting across these low points. Existing culverts serve to drain surface flows beneath the railway embankment, but evidence of ponding was observed. The site contours and nearby tributaries are shown in Figure 5-2.

BOTSWANA



### Legend

-  Towns
-  StudyArea
-  Rivers
-  Secondary rivers
-  Impoundments
-  Catchment A42J
-  Primary catchments
-  Secondary catchments
-  Tertiary catchments
-  Quaternary catchments
-  International boundary

Medupi Ash Disposal Facility

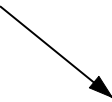

 Water Research Commission **WR 2012**

0 3 6 12 18 24 Kilometers

Coordinate System: GCS Hartebeesthoek 1994

ESKOM - MEDUPI  
Ash Disposal Facility Years 4 to 20 - Storm Water Management Plan  
Eskom Medupi ADF in relation to quaternary catchment A42J

Job No: G145-302











Figure 5-1



### Legend

-  StudyArea
-  River
-  Railway
-  Roads

### 2009 Contour Elevations

-  875
-  875 - 880
-  880 - 885
-  885 - 890
-  890 - 895
-  895 - 900
-  900 - 905
-  905 - 910
-  910 - 915
-  915 - 920

Coordinate System: Hartebeesthoek94 Lo27

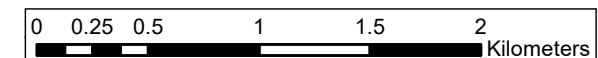

### 5.3 Rainfall and Evaporation

#### 5.3.1 Daily Rainfall Data

The Medupi PS is situated in rainfall zone A4E, an area of Mean Annual Precipitation (MAP) of approximately 400 - 500 mm (WR2012). Table 5-1 below shows the site in relation to the regional MAP and Figure 5-3 shows the rainfall stations close by.

South African Weather Service (SAWS) rainfall stations situated closest to the study area are Grootfontein, Ellisras, Sterkfontein and Tambootivlei. Relevant information for these stations was compared for selection of an appropriate station for use in the hydrological assessment of the site. This data is summarised in Table 5-1 below, and is extracted from Adamson, 1981. Southern African Storm Rainfall. Technical Report TR102, Department of Environment Affairs.

The Sterkfontein rainfall station was selected to best represent the site rainfall, based on its proximity to the site (29 km), long record length of 60 years and MAP of 456 mm, which is within the regional range of 400 - 500 mm.

**Table 5-1: South African rainfall stations characteristics closest to Medupi NAGDF (Smithers and Schulze, 2002)**

Station Name	Station Number	Distance from Site (km)	Direction from site	Latitude (degrees, minutes)	Latitude (degrees, minutes)	Record Length (years)	MAP (mm)	Altitude (msl)
Ellisras (POL)	0674400W	20	E	23° 40'	27° 44'	31	465	820
Grootfontein	0674429W	22	NE	23° 39'	27° 44'	45	440	830
Sterkfontein	0674207W	29	SE	23° 56'	27° 37'	60	456	1060
Tambootivlei	0673636W	22	NW	23° 36'	27° 21'	41	425	865

The rainfall data needed for the SWMP was extracted from the Sterkfontein station rain gauge.













BOTSWANA











Medupi Ash Disposal Facility  
MAP of 400 - 500 mm





### Legend

-  Towns
-  StudyArea
-  Rivers
-  Secondary rivers
-  Impoundments
-  Quaternary catchments
-  International boundary
-  Water Management Areas

### Mean Annual Precipitation

-  0-100 mm
-  100-200 mm
-  200-300 mm
-  300-400 mm
-  400-500 mm
-  500-600 mm
-  600-700 mm
-  700-800 mm
-  800-1000 mm
-  1000-1500 mm
-  >1500 mm

 water & sanitation  
 Department  
 Water and Sanitation  
 REPUBLIC OF SOUTH AFRICA

 Water  
 Research  
 Commission

**WR 2012**

0   4.25   8.5   17   25.5   34  
 Kilometers

### 5.3.2 24-Hour Design Rainfall Depths

The design storm depths are summarised in Table 5-2 below. The 24-hour design storm was used for storm water modelling. The 24-hour rainfall depth is the 1-day depth factored by 1.1. The reason for this is because the maximum storm event could take place over any period of the day and the 1-day rainfall depths only measure rainfall from 8am to 8am the following day. Therefore, if a large rainfall event lasting two hours started at 7am, only half the rainfall event would be attributed to either of the days when it was part of the same rainfall event.

**Table 5-2: Design Rainfall Depths for SAWS Station No. 0674429 W, Sterkfontein Station (Smithers and Schulze, 2002)**

<b>SAWS Station Name:</b>		Sterkfontein					
<b>SAWS Station Number:</b>		0674207 W					
<b>Mean Annual Precipitation (MAP):</b>		456 mm					
<b>Duration</b>	<b>Return Period (years)</b>						
	<b>2</b>	<b>5</b>	<b>10</b>	<b>20</b>	<b>50</b>	<b>100</b>	<b>200</b>
<b>24 hour</b>	64	89	108	128	154	175	197
<b>1 day</b>	58	81	98	116	140	159	179
<b>2 day</b>	70	99	119	140	168	191	215
<b>3 day</b>	78	109	130	152	180	203	226
<b>7 day</b>	97	135	160	185	218	242	268

### 5.3.3 Evaporation Data

Evaporation data for the Medupi PS site was taken from the *WR2012* for Quaternary Catchment A42J which falls into Evaporation Zone 1D. The Mean Annual Evaporation (MAE) (S-pan) in this zone is estimated to be from 1800 – 2000 mm. Refer to Section 6.2.2 of the Water Balance for evaporation data used for the site and Figure 5-4 below for the site location relative to the Mean Annual Evaporation zones.

### 5.3.4 Mean Annual Runoff

The Mean Annual Runoff (MAR) for Quaternary Catchment A42J is estimated to be 10 – 20 mm. Refer to Section 6.2.2 of the Water Balance for evaporation data used for the site and Figure 5-4 below for the site location relative to the Mean Annual Runoff.







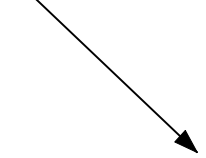



BOTSWANA











Medupi Ash Disposal Facility  
MAE of 1800 - 2000 mm



### Legend

-  Towns
-  StudyArea
-  Water Management Areas
-  Rivers
-  Secondary rivers
-  Impoundments
-  International boundary
-  Quaternary catchments

### Mean Annual Evaporation S-Pan

-  < 1200 mm
-  1200-1300 mm
-  1300-1400 mm
-  1400-1500 mm
-  1500-1600 mm
-  1600-1700 mm
-  1700-1800 mm
-  1800-2000 mm
-  2000-2200 mm
-  2200-2600 mm
-  > 2600 mm

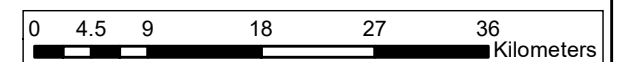

## 6. **WATER BALANCE**

In order to ensure that the PCDs associated with the Medupi NAGDF are adequately sized, to ensure a risk of spill of less than 2% in any given year over the life of the facility, a daily water balance was conducted. This is in accordance with the Best Practice Guidelines (DWAF, 2006). The modelling approach, assumptions and results of the dam sizing water balance are discussed in more detail in the following section.

### 6.1 **Modelling Approach**

Modelling of the dam sizing water balance for the Medupi NAGDF was undertaken using the GoldSim systems modelling package with the use of Microsoft Excel as a database for inputs and outputs. The following existing dams were assessed as part of the GoldSim water balance model, with new dams proposed as the footprint of the NAGDF develops:

- Existing Dam D1 (to the east of the NAGDF).
- Existing Dam D2 (to the south of the NAGDF).
- Existing Dam D2B (to the north of the NAGDF).
- Proposed Dam D3 (to the south of the NAGDF).
- Proposed Dam D3B (to the north of the NAGDF).
- The Excess Coal Stockyard Dams, namely the existing dams PCD D4 and D5 and the proposed PCDs D6, D7 and D8.

Daily rainfall data was used as input to the model, using historical data from the Sterkfontein rainfall station (SAWS station No. 0674207W), see more detail in Section 6.2.1. A daily rainfall-runoff simulation was utilised to generate runoff, evaporation and ingress values. The overall water balance was then modelled on a daily time step.

The surface runoff areas were measured from layout drawings based on the concept design of the Medupi NAGDF with dust suppression and irrigation abstracted from the relevant dams, based on information provided by Eskom. This data was entered into the water balance model in order to size the dams to ensure a 2% or lower risk of spill in any one year. Input data, largely sourced from the J&W design team, is discussed in more detail in the ensuing section.

### 6.2 **Inputs, Assumptions and Limitations**

#### 6.2.1 Rainfall data

The Daily Rainfall Extraction Utility, developed by the Institute for Commercial Forestry Research (ICFR) in conjunction with the School of Bio-resources Engineering and Environmental Hydrology (BEEH) at the University of KwaZulu-Natal, was used to obtain summary data for all rainfall stations within the vicinity of the site. This data was assessed in terms of length of record, completeness of the data set, mean annual precipitation (MAP) and location of the rainfall station with respect to the site and the catchment. The ICFR database contains daily patched rainfall data for all official South African Weather Service (SAWS) stations, and includes data up to August 2000.

The daily rainfall data needed for the dam sizing was extracted from the Sterkfontein Station rain gauge (SAWS station No. 0674207W) using the Daily Rainfall Data Extraction Utility. This station was selected due to its suitability for the site, based on the abovementioned characteristics. The Sterkfontein Station rain gauge has the longest, most reliable record for the stations in the vicinity of the Medupi Power Station. The station is located approximately 29 km from the site. Daily rainfall data extending to

August 1999 was obtained from the Daily Rainfall Data Extraction Utility (2003). A plot of the daily rainfall record (from January 1939 to August 1999) is presented in Figure 6-1.

A mass plot for the Sterkfontein rainfall station is shown in Figure 6-2. This plot shows an acceptable mass plot with some oscillations in the data set. A mass plot is a graph showing the cumulative rainfall depth with time for the full rainfall record. It is good indication of the reliability of the data set. A good mass plot will produce a straight line, with slight oscillations for seasonality. Any changes in the slope indicate a potential problem in the data set. Details of the Sterkfontein (0674207W) rainfall station are shown in Table 6-1 below.

For the purposes of the dam sizing another important factor to consider, when choosing a rainfall station, is that the chosen rainfall data set is representative of extreme events. As is clear from Figure 6-1, the Sterkfontein rainfall data set has an event, of 165 mm falling in one day, in excess of the 1:50 year 1-day event of 140 mm (Smithers and Schulze, 2002) and therefore is suitable for use in the water balance model.

The monthly average rainfall depths, together with the associated monthly evaporation depths as used in the water balance model, are depicted graphically in Figure 6-3 and tabulated in Table 6-2.

**Table 6-1: Key data for the Sterkfontein (0674207W) rainfall station**

Station Name	Station No	Distance (km)	Latitude (°)(')	Longitude (°)(')	Record (Years)	MAP (mm)
Sterkfontein	0674207W	29	23°57'	27°37'	60	456

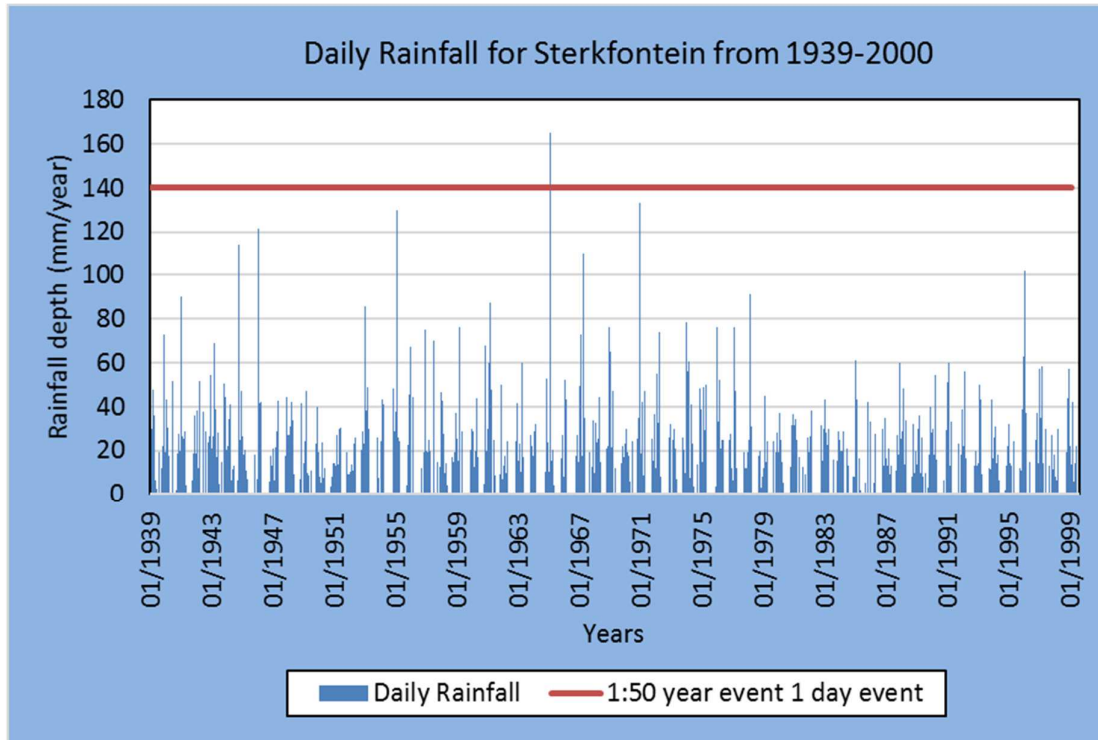

**Figure 6-1: Daily rainfall record for Sterkfontein (0674207W) rainfall station**

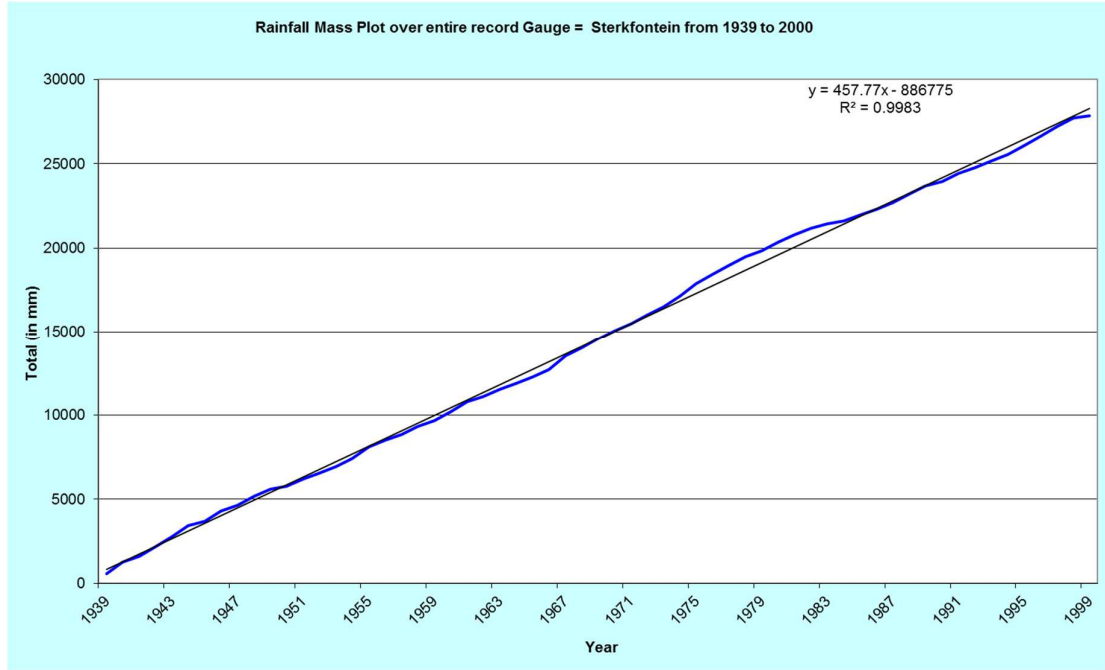

**Figure 6-2: Rainfall mass plot for Sterkfontein (0674207W) rainfall station**

A Monte Carlo simulation was conducted, in GoldSim, utilising the historical rainfall record for Sterkfontein. Monte Carlo simulations randomly select a year from the rainfall record and run the historic rainfall from that year onwards, through the model. This then means that every year in the rainfall record is applied to each year in the facility's life thus facilitating the sizing of the dams to not spill more than once in a fifty year period.

#### 6.2.2 Evaporation data

Evaporation data for the Medupi NAGDF site, as used in the water balance model was taken from "Water Resources of South Africa, 2012" (Water Research Commission, 2012) (WR2012) study, for Quaternary Catchment A42J, which falls into Evaporation Zone 1D. The average monthly evaporation depths are presented in Table 6-2 and Figure 6-3.

**Table 6-2: Average monthly rainfall and evaporation depths (from WR2012)**

Month	Average rainfall (mm)	Average evaporation (mm)
October	36.5	226.1
November	64.0	210.1
December	77.9	210.1
January	84.5	208.9
February	86.8	174.2
March	56.7	164.7
April	25.5	129.2
May	8.8	109.7
June	3.7	90.6
July	2.1	101.9
August	2.6	137.0
September	7.2	186.3
<b>Annual Total</b>	<b>456.3</b>	<b>1949.0</b>

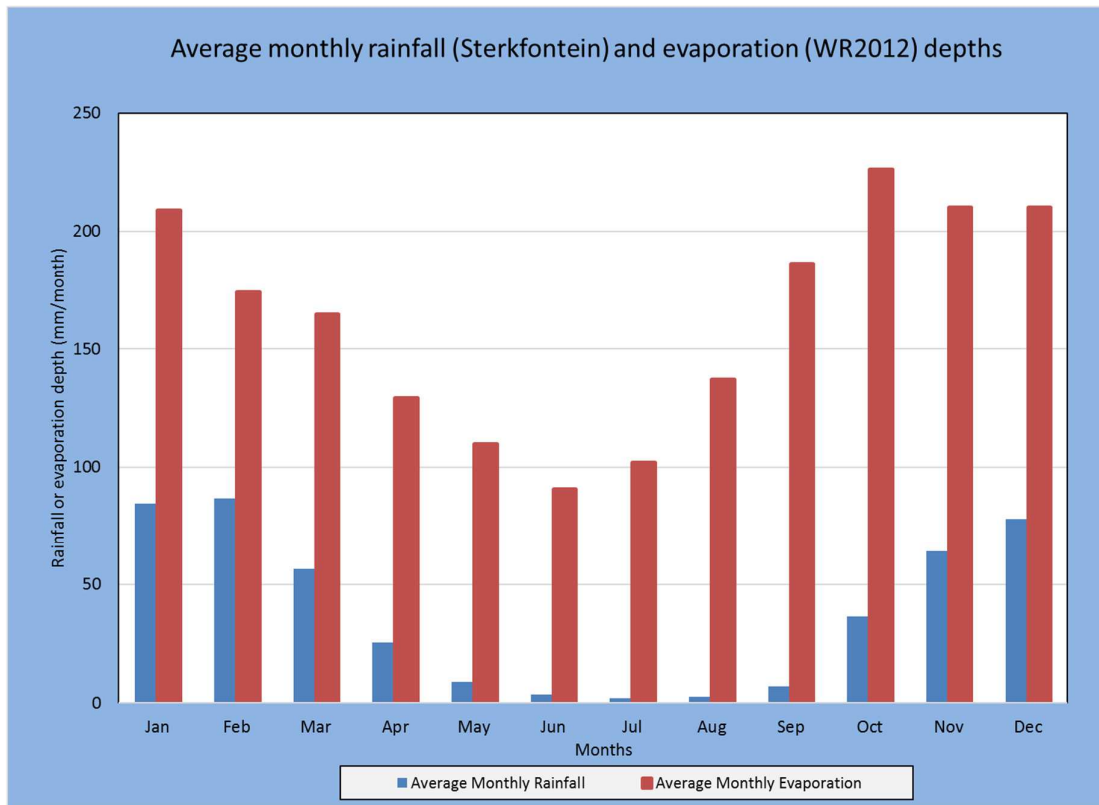

**Figure 6-3: Monthly rainfall and evaporation for the Medupi NAGDF**

### 6.2.3 Runoff modelling

Runoff modelling was undertaken using the Soil Conservation Services (SCS) runoff modelling algorithms, developed for South African conditions by the University of Kwa-Zulu Natal (UKZN). The SCS modelling takes into account 30 day antecedent rainfall and evaporation to account for antecedent soil moisture conditions. Evaporation is factored by pan factors (generic) to account for lake evaporation and crop factors (site specific) to estimate evapotranspiration rates.

An SCS curve number is selected based on the soil and vegetation type for the area. The curve number then varies through the simulation according to antecedent conditions but the range is set by the initial SCS curve number. The higher the curve number the higher the runoff. The modelling is dynamic, as antecedent rainfall, runoff and evaporation all affect the curve number.

Table 6-3 details the runoff factors that were used in the model to calculate runoff from various areas. The runoff was either calculated by means of the SCS method utilising a curve number or as a factor of veld runoff or of rainfall directly (i.e. for the lined areas). For the runoff from the ash the maximum runoff, as a percentage of rainfall, was found to equate to 37% for an event equating to approximately the 1:100 year event.

**Table 6-3: Runoff factors**

Description of area	Curve Number	Fraction of rainfall	Fraction of veld runoff
Ash	60	N/A	N/A
Liner	N/A	1	N/A
Stripped	N/A	N/A	1.2
Veld	68	N/A	1.0

Figure 6-4 provides a schematic of the catchments used in the water balance model for each four year area. Catchments were divided based on the dam to which they drain (as indicated in the figure), as well as their runoff characteristics (i.e. ash, liner, stripped, veld, coal).



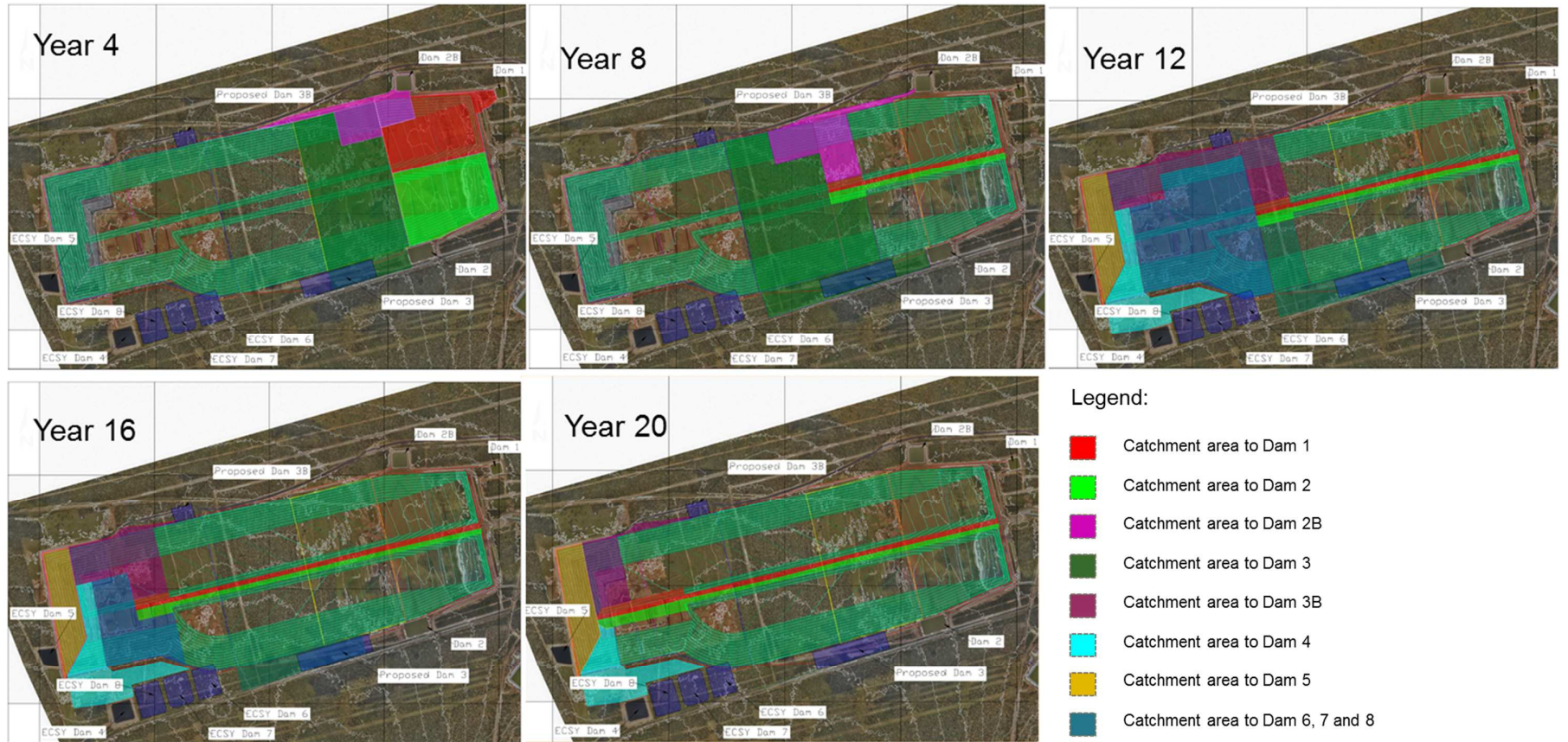

Figure 6-4: Catchment areas for each four year area

#### 6.2.4 Assumptions

The following assumptions were made pertaining to the Medupi NAGDF dam sizing:

- The active ashing area of the NAGDF was limited to 114 m in width.
- Concurrent rehabilitation will take place three shifts behind the active ashing area.
- Shifts were based on a width of 66 m – although this differs from the proposed shifting frequency detailed in Section 8.1, it has a negligible impact on the water balance.
- Areas will be lined in 2 year sections, with the area ahead of the area currently being lined being concurrently stripped in order to prepare for the installation of the liner. These areas are considered dirty due to the potential for the high sediment content of the runoff water emanating from the areas.
- The maximum dirty water area was based on the active ashing area width of 114 m, the three shifts of unrehabilitated ashing area behind the active area and the conveyor route running through the centre of the NAGDF. In addition to the above, the lined and stripped area ahead of the active ashing area also form part of the dirty water catchment that will need to be captured, conveyed and stored in the dams.
- Dust suppression was based on a required spraying depth of 16 mm per day. This is based on zero rainfall on that day. If the rainfall depth is greater than zero then the dust suppression required would be 16 mm less the rainfall depth.
- The area that will require dust suppression equated to the active ashing area and conveyor route. It was assumed that one-fifth of this total area would be sprayed per day (i.e. the entire ash area would be sprayed every week).
- It was assumed that dust suppression will first be sourced from Dam D1 at a maximum rate of 3 300 m<sup>3</sup>/day. This is based on the maximum dust suppression area per day 206 000 m<sup>2</sup> and a rate of 16 mm/day. If there is insufficient water in Dam D1 then water for dust suppression will be sourced from the other dams.
- The area that will require irrigation equated to the three shifts behind the active ashing area (i.e. the area that is in the process of being rehabilitated). It was assumed that the full area would be sprayed every day with a required depth of 6 mm per day. As for dust suppression, this required irrigation depth is based on zero rainfall on that day. If the rainfall depth is greater than zero then the irrigation required would be 6 mm less the rainfall depth.
- It was assumed that water for irrigation will first be sourced from Dam D1 at a maximum rate of 1 600 m<sup>3</sup>/day. This is based on the maximum irrigation area of 264 000 m<sup>2</sup> and a rate of 6 mm/day. If there is insufficient water in Dam D1 then water for irrigation will be sourced from the other dams.
- Currently the ECSY for Medupi lies within the NAGDF's footprint. There are two existing dams associated with the ECSY, namely PCD D4 and D5, with an additional three proposed dams (PCDs D6, D7 and D8) proposed for the ECSY. It has been assumed that these dams will be available for use for the NAGDF once the NAGDF extends to these dams. It should be noted that these dams were sized as part of the ECSY design, refer to technical note E009-00\_TCN-001\_r0\_jmnmmp\_D4\_D5\_Sizing and report JW091/17/E270.
- The following capacities were assumed for the dams associated with ECSY based on the ECSY water balances:

- PCD D4 – 69 000 m<sup>3</sup>
  - PCD D5 – 30 540 m<sup>3</sup>
  - PCD D6 – 138 600 m<sup>3</sup>
  - PCD D7 – 151 700 m<sup>3</sup>
  - PCD D8 - 151 700 m<sup>3</sup>
- A catchment divide runs through the proposed Medupi NAGDF site. The eastern portion of the site will drain to Dams D1, D2 and D2B, as well as the proposed Dams D3 and D3B, while the western portion of the site will drain to the dams associated with the ECSY (i.e. PCDs D4 to D8).
  - It was assumed that by the time that the NAGDF extends to the Year 12 line that the ECSY will no longer be utilised and that all the coal (excluding a nominal layer above the liner) will be removed to cater for the continued extension of the NAGDF.
  - The ECSY dams PCD D6, D7 and D8 were modelled as one dam, as these dams have been designed to overflow to each other before spilling into the environment, and therefore essentially act as a single entity

#### 6.2.5 Limitations

By their nature, models are theoretical estimates of natural phenomena that are too complex to be derived exactly. It is inevitable that there will be variations in the actual flows when compared to the predicted flows. This can only be addressed by the recalibration of modelled data with measured data, from which more reliable estimates of extreme and average water make and runoff volumes can be developed.

### 6.3 **Water balance analysis and results**

Based on the aforementioned assumptions a daily water balance for the Medupi NAGDF was modelled. This water balance was used to size the dams associated with the NAGDF. The results of the water balance are discussed in this section.

#### 6.3.1 Schematic flow diagram

The schematic water balance diagrams are presented in Figure 6-5. This figure shows all the entities that were considered as part of the dam sizing water balance model for the Medupi NAGDF.

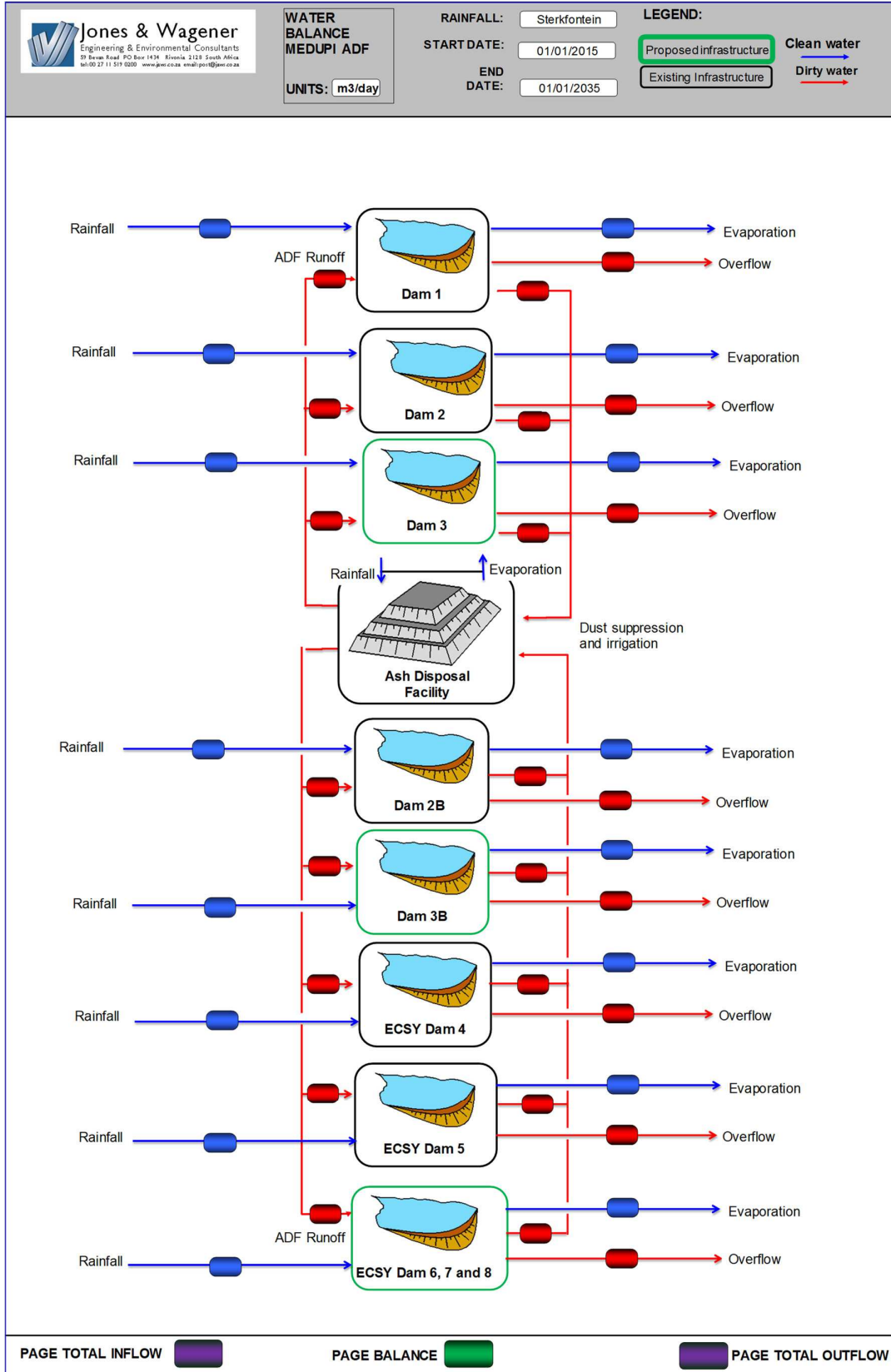

Figure 6-5: Schematic flow diagram for the Medupi NAGDF

### 6.3.2 Dam sizing

Two new PCDs have been proposed as part of the Medupi NAGDF extension from the 4 year to 20 year life. These include:

- The Dam D3
- The Dam D3B

The existing dams associated with NAGDF will continue to be used (i.e. Dam D1, D2 and D2B) together with the existing dams associated with the ECSY (i.e. PCDs D4 and D5) as well as the proposed dams associated with the ECSY (i.e. PCDs D6 to D8).

The details of the existing dams, as well as the proposed dams at the ECSY, in terms of their capacities and Full Supply surface areas are detailed in Table 6-4.

**Table 6-4: Existing dam capacities**

Dam description	Capacity (m <sup>3</sup> )	Full Supply Surface Area (m <sup>2</sup> )
Dam D1	18 300	8 280
Dam D2	48 700	27 000
Dam D2B	45 000	18 500
ECSY PCD D4	69 000	25 000
ECSY PCD D5	30 540	157 700

South African legislation, detailed in Government Notice 704 of 1999 (GN R704), in terms of the National Water Act, Act 36 of 1998 (NWA), stipulates that dirty water needs to be contained for events up to the 1:50 year recurrence interval. The Department of Water and Sanitation (DWS), previously Department of Water Affairs and Forestry (DWAF), Best Practice Guideline for water management defines a spill “event” as a series of spills occurring during a given 30 day period.

When determining storage requirements and a water management strategy for extreme rainfall, it is important to understand that a particular recurrence interval does not refer to a single discrete event. For each recurrence interval there is an infinite number of events, depending on the storm duration considered. It is important to determine the appropriate storm duration to use, based on the assessment being carried out. Typically, for peak flow events, shorter duration events (< 24 hours) are considered, as these are of higher intensity and generate greater flow rates. However, for volumetric assessments (sizing of dirty water containment facilities), the duration used could be months, an entire season, or longer, as two or three months of high rainfall, for example, could raise a dam’s water level to such an extent that a subsequent low recurrence interval storm could cause a spill event. Therefore, a daily water balance model was used for the dam sizing, based on historical rainfall. This approach is also in line with the DWS Best Practice Guidelines.

The risk of spill from a PCD is a function of both dam capacity (for temporary storage of storm water runoff) and the rate at which water can be abstracted from the dam for reuse or safe disposal elsewhere. In order to determine the required dam sizes, the historical rainfall record was utilised and run through the water balance model using Monte Carlo simulations. The critical rainfall sequence, based on the historical rainfall record, was ascertained and the dam was sized such that the dam would not be expected to spill more than once in a 50 year period, in line with GN R704. Table 6-5 summarises the required dam capacities for the proposed dams associated with the Medupi NAGDF,

while Figure 6-6 to Figure 6-8 illustrate the dam volume over time that was used to determine the required dam sizing for the proposed PCDs.

**Table 6-5: Proposed dam capacities**

Dam description	Capacity (m <sup>3</sup> )	Required timing
Dam D3	260 000	Year 4 (i.e. 2019) when lining of Year 4 to 8 commences
Dam D3B	55 000	Year 12 (i.e. 2027)
ECSY PCD D6	138 600	Year 12 (i.e. 2027)
ECSY PCD D7	151 700	Year 12 (i.e. 2027)
ECSY PCD D8	151 700	Year 12 (i.e. 2027)

It should be noted that the proposed dam capacities for the ECSY dams are based on the dam sizing for the ECSY and not for the NAGDF. Therefore, these dams were sized for the ECSY and the associated water management and abstraction parameters associated with the ECSY and not the NAGDF. As can be seen from Figure 6-13 the proposed capacities for the ECSY PCDs D6, D7 and D8 are more than adequate for the purposes of the NAGDF. If only PCD D6 were to be constructed, this would be sufficient to cater for the NAGDF, as is shown in Figure 6-14. Similarly, for the ECSY PCD D4 and PCD D5 these are existing dams sized for the ECSY area. Their existing capacities are more than adequate for the NAGDF catchments that would report to them, as can be seen in Figure 6-11 and Figure 6-12.

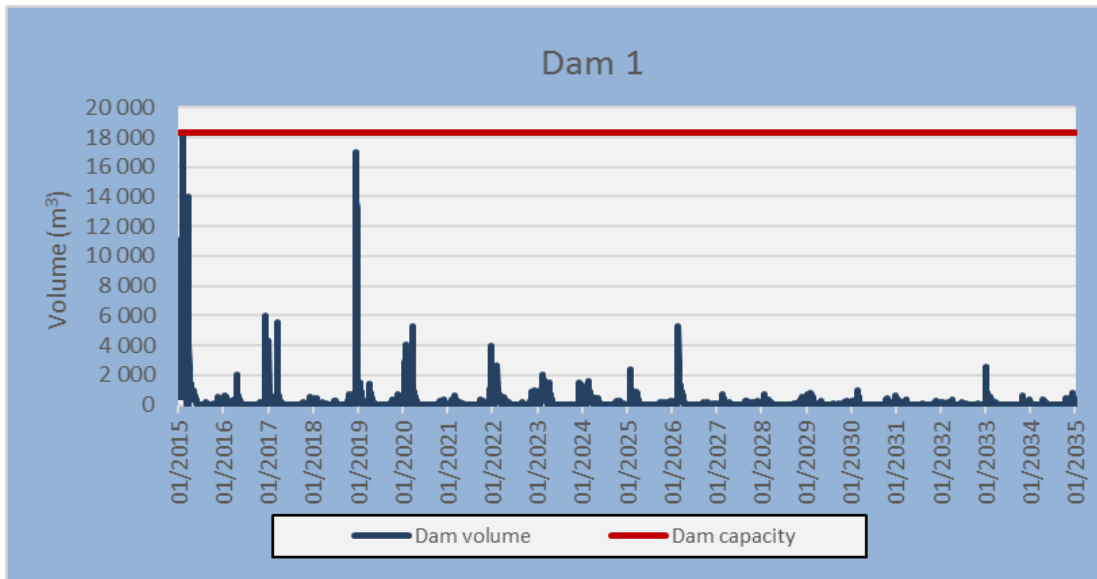

**Figure 6-6: Dam D1 dam volume over time plot**

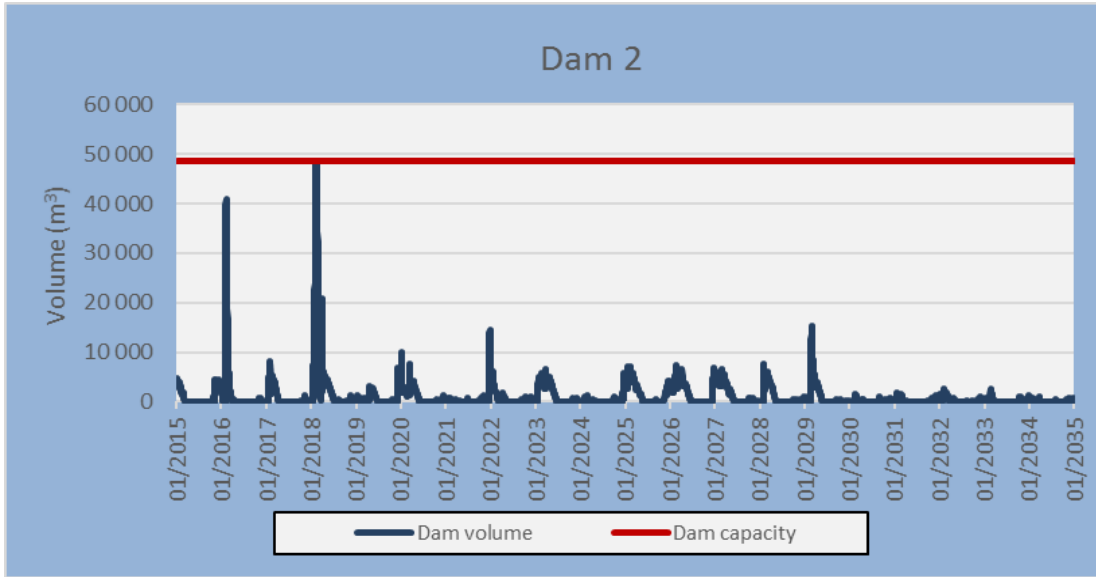

Figure 6-7: Dam D2 dam volume over time plot

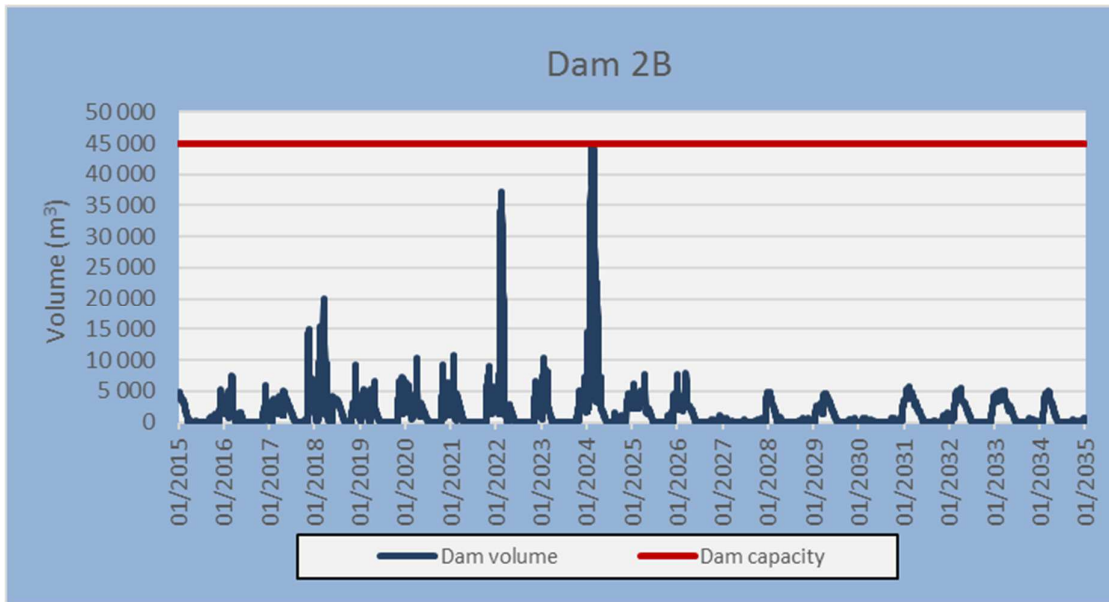

Figure 6-8: Dam D2B dam volume over time plot

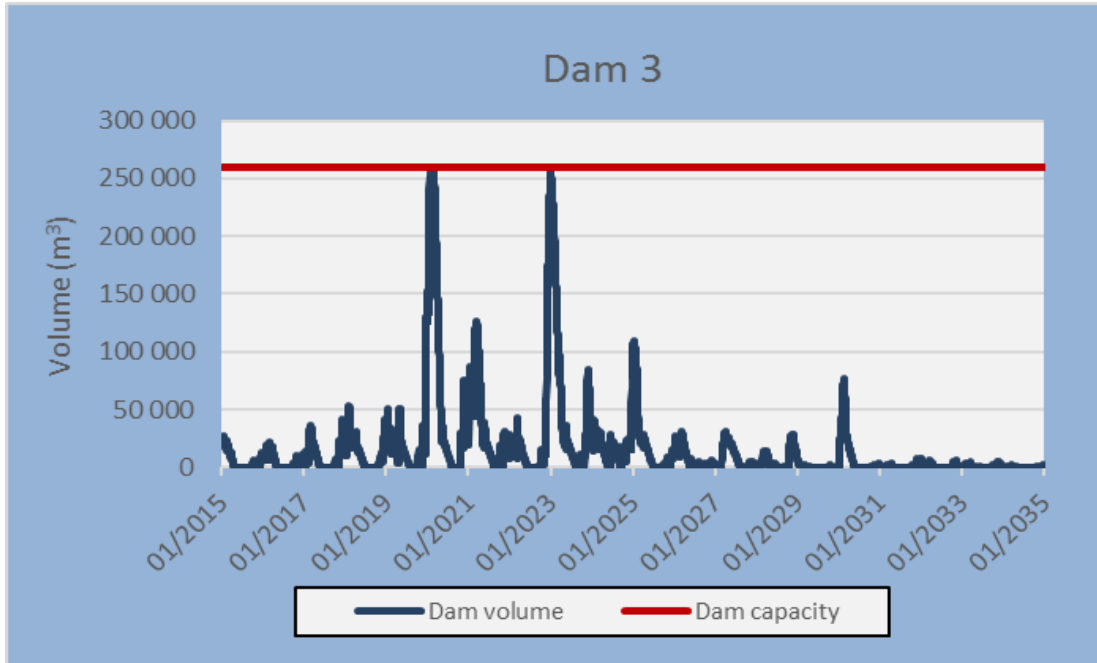

Figure 6-9: Dam D3 extension dam volume over time plot

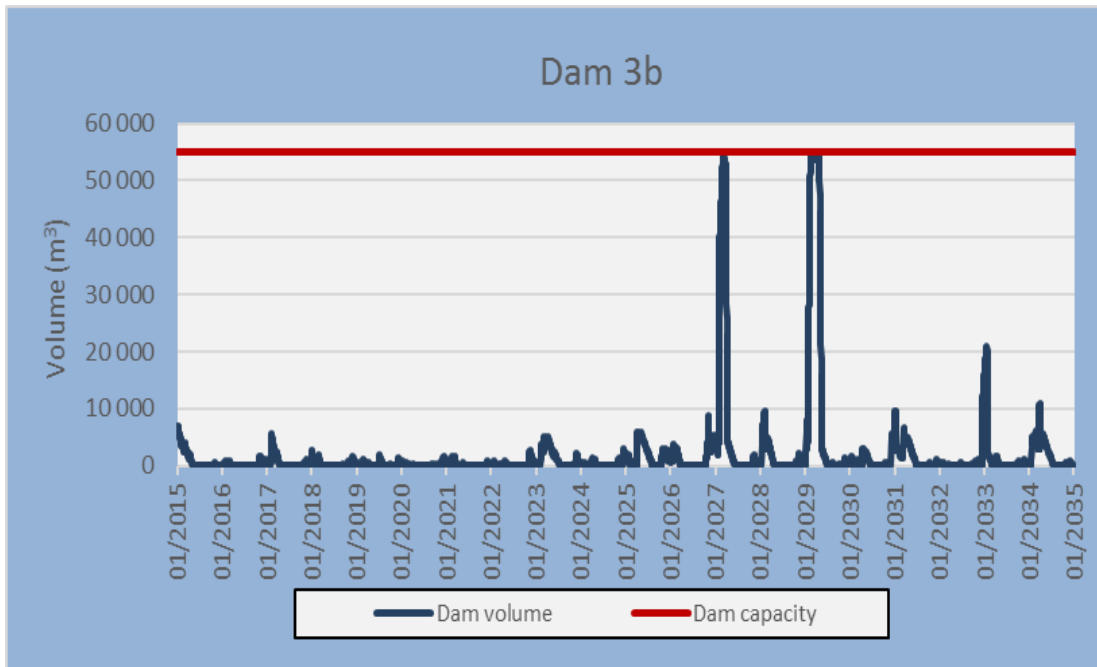

Figure 6-10: Dam D3B dam volume over time plot



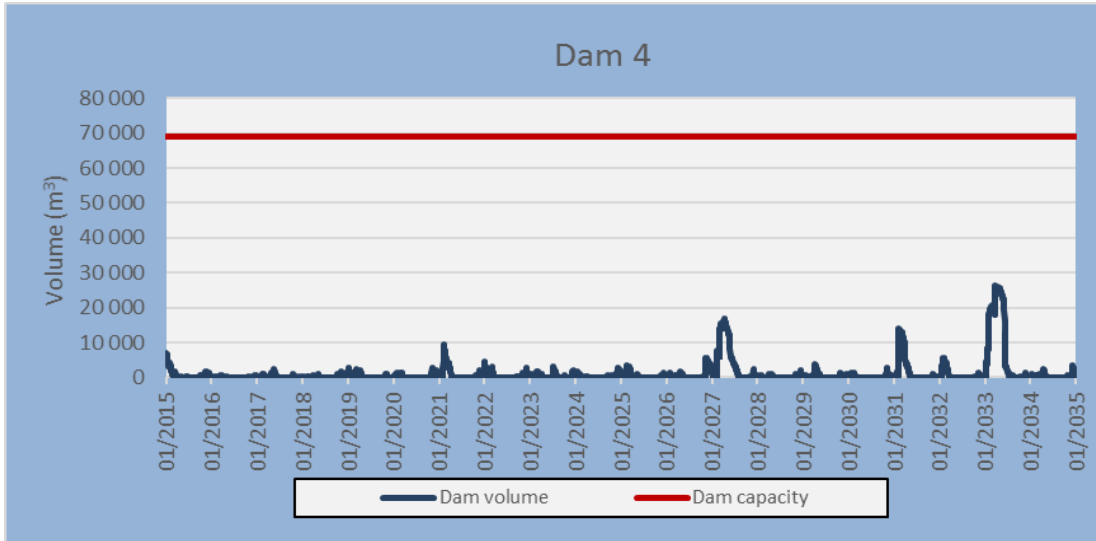

Figure 6-11: ECSY PCD D4 dam volume over time plot

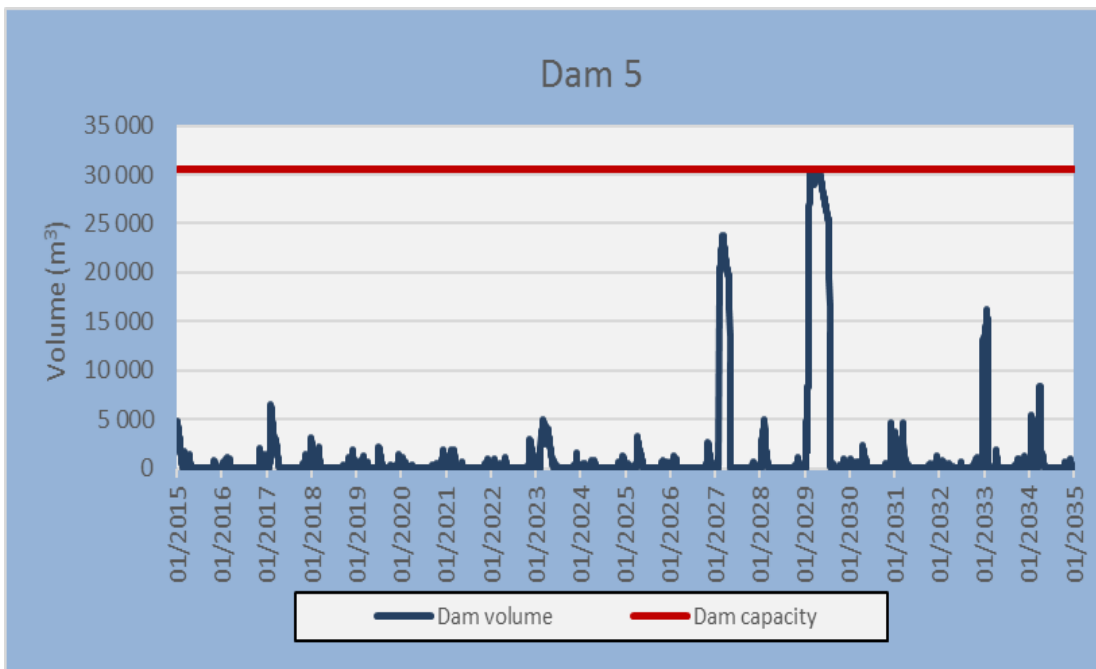

Figure 6-12: ECSY PCD D5 dam volume over time plot

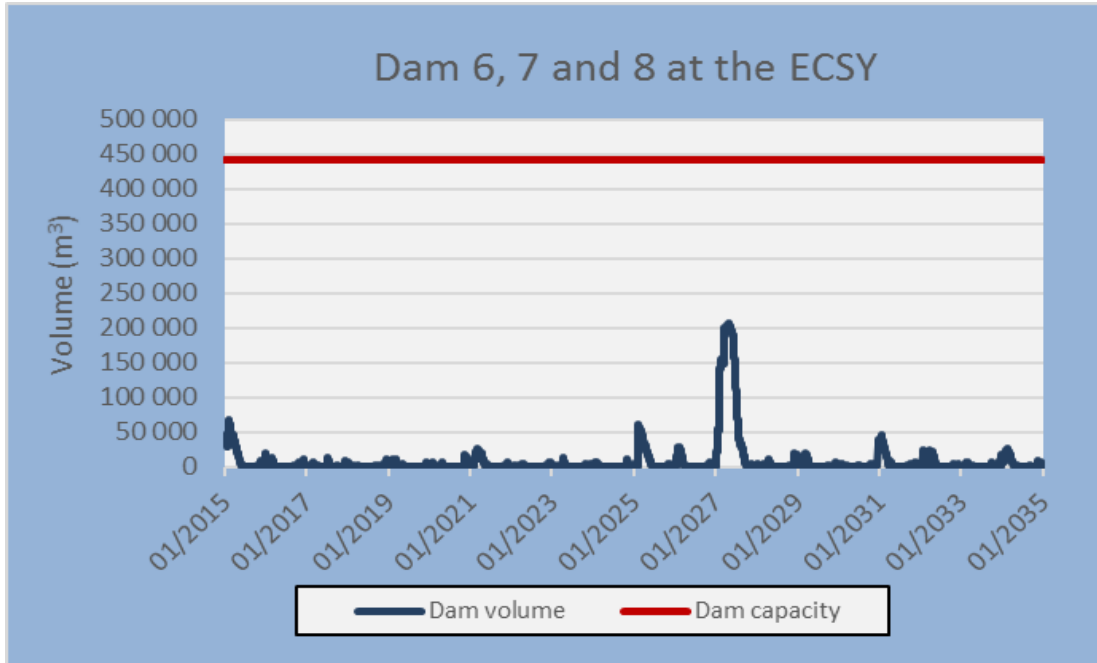

Figure 6-13: ECSY PCD D6, D7 and D8 dam volume over time plot

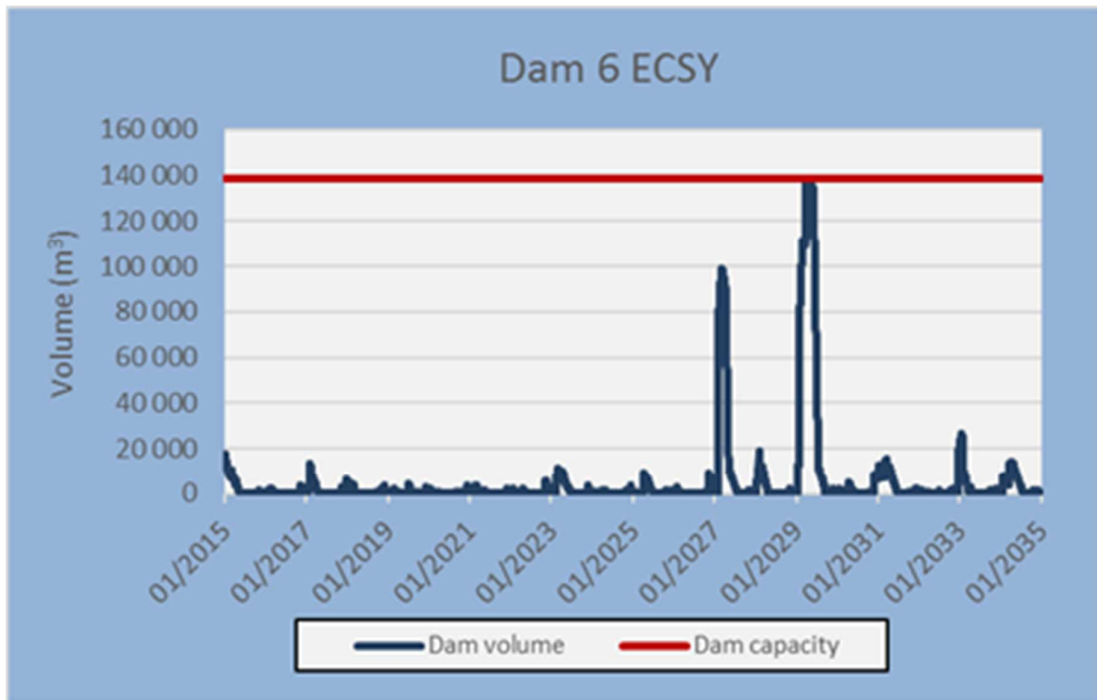

Figure 6-14: ECSY PCD D6 only volume over time plot

It should be noted that these dam sizes are based on water being abstracted from the dams for both dust suppression and irrigation. Water is first drawn from Dam D1 and then from Dam D2 and then from Dam D2B. The maximum pump rates required from the various dams, for dust suppression and irrigation, are stipulated in Table 6-6.

**Table 6-6: Required dam abstraction rates for dust suppression and irrigation**

Dam description	Maximum abstraction rate for dust suppression and irrigation (m <sup>3</sup> /day)*
Dam D1	3 350
Dam D2	3 350
Dam D2B	3 350
Dam D3	3 350
Dam D3B	3 350
ECSY PCD D4	3 350
ECSY PCD D5	3 350
ECSY PCD D6, D7 and D8	3 350

\*It should be noted that the maximum irrigation rate is 1 600 m<sup>3</sup>/day and the maximum dust suppression rate is 3 300 m<sup>3</sup>/day. As mentioned previously these are based on the maximum associated areas and the associated daily rate. The maximum areas for dust suppression and irrigation however do not coincide resulting in a lower maximum total abstraction than the sum of the two maximum rates.

A second water balance scenario was assessed for a reduced dust suppression and irrigation rate. In this second scenario the dust suppression and irrigation rates were halved (i.e. 8 mm/day and 3 mm/day respectively). This resulted in a maximum abstraction rate from the dams of 1 675 m<sup>3</sup>/day. The results of this second scenario with respect to the required dam sizes is summarised in Table 6-7 below.

Maximum abstraction rates are supplied for use by operations for planning purposes. It must be ensured that available pumping capacity can achieve these rates, whether it be by mobile pumping or a permanent pump station, in order to prevent spill from the dam for any event up to the 1:50 year event.

A nominal, or minimum pump rate is not supplied as such a boundary is not meaningful in this application. The minimum rate would be zero, and pumping activity would vary with time depending on the volumes in the PCD. It is rather the available storage capacity of the PCD that should be maximised. Therefore, pump as required to keep the water level in the PCD to a minimum.

It is important to note that a PCD is not a water storage facility and should not be operated as such. It is a buffer storage system for extreme events and should, as far as is practical, be operated empty at all times.

**Table 6-7: Required dam capacities based on a reduced abstraction rate from the dams**

Dam description	Scenario 1 existing/required dam capacity (m <sup>3</sup> )	Scenario 2 existing/required dam capacity (m <sup>3</sup> )
Dam D1	18 300*	26 300
Dam D2	48 700*	48 700*
Dam D2B	45 000*	60 000
Dam D3	260 000	330 000
Dam D3B	55 000	55 000
ECSY PCD D4	69 000*	69 000*
ECSY PCD D5	30 540*	30 540*
ECSY PCD D6, D7 and D8	442 080**	442 080**

\* Existing capacity \*\* Proposed capacity based on ECSY requirement but not required for NAGDF

Based on the above table Dam D1, Dam D2B and Dam D3 will need to be larger than the capacity proposed in the first scenario of the water balance. In the first scenario the abstraction rate from the dams was based on a dust suppression rate of 16 mm/day and an irrigation rate of 6 mm/day. Both Dam D1 and Dam D2B are existing dams and would need to be extended, which would be challenging due to spatial constraints. Therefore, it is proposed that the abstraction rate from the dams be as per the first scenario. This implies that the existing dams' capacities are adequate (as defined in Table 6-4) and the proposed dams need to be constructed as per Table 6-5.

## 6.4 Conclusions and Recommendations

Based on the above results the following conclusions and recommendations can be made:

- The existing dam Dams D1, D2 and D2B are of an adequate capacity for their associated catchments, based on abstraction for dust suppression and irrigation as specified above.
- Pumping capabilities need to be provided at Dam D2 and D2B for dust suppression and irrigation. The maximum expected pump rate from these dams is 3 350 m<sup>3</sup>/day.
- A second dam is required to the south of the NAGDF, namely Dam D3. The required capacity of Dam D3 is 260 000 m<sup>3</sup>. This dam will be required when lining of the year 4 to 8 area begins to cater for runoff from the liner area.
- Pumping capabilities need to be provided at this dam for dust suppression and irrigation. The maximum expected pump rate from this dam is 3 350 m<sup>3</sup>/day.
- A second dam is required to the north of the NAGDF, namely Dam D3B. The required capacity of Dam D3 is 55 000 m<sup>3</sup>. This dam will be required in year 12 of the NAGDF life.
- Pumping capabilities need to be provided at this dam for dust suppression and irrigation. The maximum expected pump rate from this dam is 3 350 m<sup>3</sup>/day.
- The ECSY dams, both existing and proposed, are sufficient for the NAGDF footprint. Pumping capabilities need to be provided at these dams for dust suppression and irrigation. The maximum expected pump rate from these dams is 3 350 m<sup>3</sup>/day.
- Alternative water sources will be required to meet the dust suppression and irrigation requirements, particularly in the dry season. Water for irrigation to be tested and assessed for effect on germination. Water may need to be sourced from an alternative source if the quality is too poor for efficient germination.

## 7. STORM WATER MANAGEMENT PLAN

### 7.1 Storm Water Management Philosophy

When rain falls onto the operational Medupi NAGDF its water quality will be altered and the runoff flow characteristics will differ from the natural catchment. An effective surface water management system is thus essential to protect surrounding natural resources from pollution. This is accomplished by diverting clean water away from the site, capturing and containing dirty runoff, and separating clean water from the rehabilitated NAGDF and the operational area. Dirty runoff volumes will be minimised by preventing the inflow of clean runoff into dirty areas and keeping dirty areas as small as possible.

The Sandloop River is located to the south of the site, and drains the NAGDF catchment and may potentially be affected by NAGDF runoff. Measures to minimise these potential impacts to the Sandloop River are thus required.

Separation of dirty from clean catchments will be achieved by the following measures:

- The use of separation berms, between the natural or rehabilitated areas and the operational areas.
- An over-under system isolating the rehabilitated area from the operational area.
- Containment of contaminated flows in lined PCDs.
- The prevention of spill of contaminated storm water trenches and PCDs by ongoing abstraction of dirty water for use in the operational area.
- Concurrent rehabilitation of the NAGDF surface, as close as possible to the active disposal area.
- Ongoing surface water monitoring as per surface water specialist recommendations in report 1415879-310165-2: *Surface Water Impact Assessment and Baseline Draft Report for Medupi Power Station* (Golder Associates Africa (Pty) Ltd, 2017).
- Return of clean runoff from the rehabilitated areas of the NAGDF to the environment for recharge of the Sandloop River system.

A conceptual SWMP has been developed for the Eskom Medupi NAGDF for years of life 4 to 20. The plan addresses the storm water requirements and connects into existing infrastructure from years of life 0 to 4 and the ECSY, discussed in detail in Section 7.4 below.

## 7.2 Storm Water Management Plan Objectives

The primary objective of the SWMP is to ensure compliance with the South African legislation in terms of dirty storm water containment at the facility. Achieving containment will support the intention of minimising the impact of the facility on the receiving environment.

## 7.3 Design Criteria

The proposed storm water management infrastructure is required to comply with current legislation in terms of clean and dirty water separation. The legislation, policies and guidelines that were considered during the storm water management and storage design for the Eskom Medupi NAGDF are listed in Section 1.2.

GN 704 states that clean and dirty water systems must not spill more than once in 50 years. This translates to a 2 % or lower risk of spill in any one year. This requirement is fulfilled by designing to the 1:50 year storm event based on the hydrology for the site, discussed in Section 5 above.

The key design criteria are therefore as follows for storm water trenches:

- The canals have been sized to accommodate the expected 1:50 year peak flow event.
- Clean and dirty water trenches are separated.
- The freeboard requirements, for storm water trenches, are based on the requirements as set out in the SANRAL Drainage Manual (SANRAL, 2007). This is based on the specific energy or flow depth of the water, depending on whether the flow regime is subcritical or supercritical. As a guideline, if the peak flow rate is

less than 10 m<sup>3</sup>/s, then 0.3 m of freeboard is considered adequate and if the peak flow rate is greater than 10 m<sup>3</sup>/s, then 0.6 m of freeboard is considered adequate.

The key design criteria with respect to the PCDs are as follows:

- PCDs should be designed, constructed, maintained and operated such that the dams have a minimum freeboard of 0.8 m above full supply level.
- PCDs have been sized based on a daily water balance, including a pumping abstraction out of the PCD, to ensure that they will not spill into any clean water system more than once in 50 years, in accordance with GN R704.
- The spillways and freeboard on the dams should be sized in accordance with the “*Guidelines on Freeboard for Dams*” (SANCOLD 2011).

#### 7.4 Existing Storm Water Management Infrastructure

This section discusses the broader SWMP surrounding the Eskom Medupi NAGDF before detailing the specific dirty and clean water containment and management measures that have been proposed as part of this design. Figure 7-1 shows a schematic layout of all the storm water related infrastructure that is assumed to be existing at year of life 4 of the NAGDF while Table 7-1 includes a summary of the existing contaminated storm water trenches.

**Table 7-1: Summary of contaminated storm water trenches existing at 0 to 4 year area of the NAGDF**

Existing Trench:	Draining to:	Depth (m)	Invert Width (m)	Side Slopes
Northern trenches	Dam D1	0.6 - 1.0	0.8	1:1.5
	Dam D2B	0.6	0.8	1:1.5
Eastern trenches	Dam D1	1.3	0.8	1:1.5
	Dam D2	1.3	0.8	1:1.5
Southern trenches	Dam D2	1.3 - 2.0	0.8	1:1.5
ECSY trenches	PCD D4	0.75	1.0	1:2
	PCD D5	0.75	1.0	1:2

Currently there are three PCDs, associated with the Eskom Medupi NAGDF, namely Dam D1, Dam D2 and Dam D2B. In addition, within the NAGDF’s final footprint, approximately 2.5 km to the west of the current NAGDF 4 year extent, the ECSY is situated with associated storm water infrastructure and PCDs. Currently there are two dams associated with the ECSY, with a further three dams proposed for the ECSY extension. The final extent of the ECSY will be to the 12 year life of the NAGDF. It has been assumed that once the NAGDF reaches its 12 year life, the coal will have been reclaimed with the exception of a nominal layer of coal above the liner, and that PCDs associated with the ECSY can be utilised for the NAGDF.

Runoff from the NAGDF currently drains to Dams D1, D2 and D2B by means of geocell lined perimeter canals. These geocells are filled with cement stabilised sand. However, erosion has been noted in these canals and therefore, going forward, these will be lined with geocells infilled with concrete to improve durability. As part of the SWMP it has been proposed that the three existing dams continue to capture and contain dirty runoff and seepage emanating from the NAGDF, with two new dams proposed to cater for the NAGDF extension and runoff from the lined areas associated with the NAGDF extension, as per the water balance findings.

## 7.5 Proposed Contaminated Storm Water Management System

The SWMP entails the management of both rehabilitated runoff water, clean water and dirty water. The conceptualisation and design of the SWMP has been done with a phased approach. This means that as the footprint of the NAGDF extends so too will the associated storm water management infrastructure. Dirty water will be captured and conveyed to the PCDs by means of perimeter canals. In addition to the dirty water perimeter canals, dirty water generated along the conveyor corridor will be conveyed to Dam D1 by means of conveyor corridor canals. In line with the phased approach described above, these canals will be extended as an area is disturbed (i.e. stripped and prepared for lining). Generally, storm water emanating from the dirty area will be allowed to runoff into the dirty perimeter canals surrounding the facility, with only temporary storm water management measures within the footprint of the facility for runoff management prior to ash placement on prepared surfaces.

Rehabilitated runoff and clean water diverted away from the dirty area will be conveyed and discharged into the environment via energy dissipaters to prevent erosion.

The proposed SWMP at the Eskom Medupi NAGDF for the development of the facility from year of life 4 to 20, in order to achieve compliance, is outlined in the sections that follow. Firstly, the elements comprising the contaminated and then the clean storm water management systems are described, followed by a detailed explanation of the approach and methodology used for the determination and optimisation of the SWMP layout and sizing. The findings of the assessment are then presented.

### 7.5.1 Contaminated Storm Water Collection Trenches

A storm water drainage system will be located along the perimeter of the NAGDF and will serve to direct storm water from it to the PCDs. It will serve the dual function of conveying the NAGDF seepage from the leachate collection system (LCS), which will enter it from the LCS outfall pipes. These perimeter trenches will be extended as the NAGDF advances and are indicated schematically in Figure 7-2, Figure 7-3 and Figure 7-4 for each phase of development.

The trenches will be lined with concrete infilled geocells, overlying an HDPE geomembrane to prevent any infiltration of contaminated water into the in-situ soils.

The following will be required:

- Upgrade of existing year of life 0 to 4 trenches to accommodate larger flows from NAGDF.
- Construction of new perimeter trenches for the advancing NAGDF.
- Tie-in of new perimeter trenches to existing ECSY trenches.

### 7.5.2 Conveyor Corridor Storm Water Management

Rain falling on the 70 m wide conveyor corridor will become contaminated by contact with ash. The conveyor platform has a cross fall of 2% about its centreline, draining towards concrete-infilled-geocell lined storm water trenches located on either edge of the corridor. These flows are thence conveyed to a drop-box structure which carries flow through pipes and into perimeter storm water trenches. The northern half of the conveyor platform will have its runoff directed to Dam D1, and the southern half to Dam D2. These canals will be extended with the conveyor platform as the active diposal face extends.

## 7.6 Proposed Clean Storm Water Management System

In order to comply with GN R704, it is required that any unpolluted runoff be confined to the clean water system and diverted away from any dirty area. In addition, clean water systems should be designed, constructed, maintained and operated so that they are not likely to spill into any dirty water system more than once in 50 years. This legislation formed the basis of the design of the clean and dirty water separation and clean water management infrastructure associated with Medupi NAGDF and its extension.

### 7.6.1 Diversion of Clean Water from Undeveloped Areas

From year of life 4 to 12, the area west of the active disposal facility is natural veld. In order to prevent contaminated water from the stripped and lined areas of the NAGDF footprint from draining onto the clean, undeveloped natural veld and subsequently polluting it, an upslope cut-off berm is required at the edge of each four-year area to divert runoff and should be constructed prior to stripping of the land.

From year of life 12, the NAGDF will intersect the ECSY area and the catchment ahead of the advancing facility would be considered contaminated and is already lined, so no clean cut-off is required and all contaminated runoff will be contained within the ECSY footprint and be drained by the LCS system.

The upstream catchment area is small as the northern boundary of the facility coincides with a ridge (along which runs the unnamed public road connecting to the R510 provincial road in the east). The western side of the ridge drains to the south, towards the facility while the eastern portion drains in an easterly direction, away from the facility. Clean runoff volumes flowing south are thus anticipated to be small, as the surface is undeveloped and fully vegetated, with a contributing catchment of approximately 45 hectares. Clean water diversion infrastructure is neither currently in place or planned, and clean areas are assumed to be free draining. PCDs are raised above natural ground level and do not receive any surface runoff from the surrounding clean catchment. The catchments immediately adjacent to the contaminated storm water trenches on the perimeter of the site are assumed to be dirty and report to the trenches. It is recommended that a clean cut-off trench be installed to the upslope boundaries of the site. This would be the northern and western boundaries. These trenches would serve to divert away upstream flows from undeveloped areas and clean runoff from the rehabilitated NADF in future. Existing road infrastructure may be reassigned to this purpose. These opportunities would need to be assessed when the rehabilitated stage is reached.

The floodlines for the Sandloop River were determined by Golder Associates Africa as part of the Surface Water Impact Assessment for Medupi Power Station (Report Number 1415879-310165-2, 2017). It was found that the 1:50 and 1:100 year floodline for the Sandloop River is predicted to encroach on ECSY PCD D4. It is not anticipated that flood protection works will be required on the toe of the PCD as the water level would rise because of ponding against the railway crossing embankment to the south of the site. Flow velocities would therefore be low and the risk of erosion minor. If the water surface elevation of the river is high enough to overtop the crest of PCD D4 (904.70 msl), then this would constitute a spill as clean water from the environment is entering a dirty system. In this instance, the western and southern walls of PCD D4 will need to be raised to prevent inflow of flood waters. This information was not available in the floodline report. It is recommended that during detailed design, floodlines are carried out to a higher level of accuracy using a survey that reflects PCD D4 to determine the exact extent to which ECSY PCD D4 falls within the floodline and what the water level would be, and raise the embankment of the dam if required.



### 7.6.2 Rehabilitation Clean Water Management and Diversion

The rehabilitation process of the NAGDF includes shaping of its surface with earth-moving equipment into the final landform shape, followed by laying a 300 mm thick hydroseeded topsoil covering. During this period, the hydroseeded topsoil will be irrigated with water from the PCDs. This period ends when rehabilitation of the next shift begins. Once vegetated, the catchment is considered clean and will be irrigated by direct rainfall only. The time of year that rehabilitation occurs is important to its success, and should be planned to coincide with the wet season (starting in October). Vegetation is assumed to establish within 3 months. If water infiltrates the ash and gypsum body it will be collected by the LCS and will be prevented from entering the natural soils by the lining system.

As part of the design of the Medupi NAGDF it has been assumed that rehabilitation will occur three shifts behind the active ashing area. These three shifts are in the process of being rehabilitated (pre-rehab areas) and are still considered dirty, meaning that storm water runoff from these areas needs to be contained in the PCDs and is managed as part of the contaminated storm water management system.

The overall clean storm water management plan for the fully rehabilitated area consists of several aspects. This is discussed in two parts and is covered in the ensuing sections:

- Storm water management on the crest of the NAGDF.
- Storm water management on the side slopes of the NAGDF.

Runoff is conveyed and discharged into the environment by means of bench berms and pipes on the side slopes and diversion berms and canals on the top of the NAGDF. The pipes on the side slopes discharge, via energy dissipaters, into the environment.

Rehabilitation of the facility is both beneficial to the environment, minimises risks to the liner system in the long-term and has economics benefits in that the capacity required in the dirty water system is optimised. Surface runoff from the rehabilitated areas will not be contained on the site but will be released immediately in order to preserve the runoff volumes currently reporting to the Sandloop River system for its recharge.

The environmental impact of the NAGDF on its surrounds will be reduced by rehabilitation by the following means:

- The natural topography of the site will be modified by the introduction of the facility, that extends approximately 4 km in length and 1.3 km in width, rising to a maximum of 72 m above natural ground level (to an elevation of 983.7 msl). Runoff quantities are thus anticipated to increase due to the steep slopes of the facility. The rehabilitated form aims to improve the surface from ash to vegetation, which decreases the rate of runoff. The back-stack berms and side benches reduce the gradient of the slopes of the facility, allowing water to pond before entering the collection pipes. Clean storm water from the rehabilitated areas is then released in a controlled manner into the natural environment.
- Water quality is impacted by contact with the ash body. By capping the NAGDF with topsoil and vegetation, the rain falls on a clean surface, preventing the introduction of pollutants into receiving watercourses. Sediment transport by wind and water is reduced as the vegetation anchors the surface.
- Rehabilitation of the facility, including reduction of the gradient of the slopes and restoration of surrounding vegetation, will allow the facility to better blend into the environment. This minimises the aesthetic impact of the NAGDF.

## 7.7 Approach and Methodology

Five phases of development of the NAGDF were defined: Year 4, Year 8, Year 12, Year 16 and Year 20. For each phase the storm water collection systems, rehab progression, storage facilities and sub-catchments were modelled. From year of life 12, the facility meets the ECSY and aside from the catchment definitions altering as the NAGDF advances, storm water management infrastructure remains constant.

Modelling of the surface runoff flows for discrete, extreme events on the progressing Eskom Medupi NAGDF was undertaken using the hydraulic modelling programme *PCSWMM 2013 Professional 2D: Storm Water Modelling Software*. The software applies a storm hyetograph to the sub-catchments, characterised by user-defined inputs, and routes the resultant surface flows through the proposed storm water management system.

The 1:50 year 24-hour storm event, with a rainfall depth of 154 mm, was applied as a South African SCS Type 3 design storm (Schmidt and Schulze, 1987). Resultant runoff was determined based on catchment characteristics and using the SCS method, as described in Section 6.2.3.

Survey of the site from February 2017 was used as far as possible in the laying out of the storm water infrastructure. It was found that in some areas due to topsoil stockpiling and the ECSY the survey was not suitable for determining natural ground level. For these areas the 2009 survey data as supplied by the client was used.

The outcomes of the modelling were used to reiterate and assess the hydraulic elements, until optimal layout and sizing was identified.

## 7.8 Assumptions

The following assumptions were made in the modelling of the Eskom Medupi NAGDF storm water management planning:

- The ECSY is not included in the progressive SWMP as the design for its infrastructure has been carried out independently and is thus excluded from this scope.
- For development phase from the start of year of life 4, it was assumed that the entire area is not rehabilitated. This conservative assumption was made on the basis that during year of life 0 to 4, the conveyor platform is still being established and the entire surface is considered operational.
- The operational area has a surface of exposed ash & gypsum and runoff is considered dirty. It consists of the active disposal area and the pre-rehab area.
- Rainfall runs off the crest and sides of the operational area (the active disposal area and the pre-rehab area) as sheet flow and there are no storm water management measures on the active ash heap.
- The 114 m wide operational ashing area has side slopes equivalent to the angle of repose - 1:1.5 or 67 %, while the pre-rehab area has side slopes as per the final landform design of 1:5 or 20 %.
- The 114 m wide operational ashing area will have its runoff pond in the lined area between its toe and the edge berm. Pondered water will then flow out of the leachate outfalls into perimeter contaminated storm water trenches.
- The 180 m wide pre-rehab area will have its toe flush with the edge berm, and its runoff will flow directly into the perimeter contaminated storm water trenches.
- It is assumed that there is a contaminated storm water trench along the south-east side of the NAGDF for year of life 4 as per year 0 to 4 design specification.

- From shift 11, the shifts will decrease from 66 m wide to 60 m wide.
- Undeveloped, clean areas are assumed to be free draining.
- The western boundary of the NAGDF is assumed to have paddocks remaining from the ECSY arrangement for use as attenuation storage.

All assumptions pertaining to the water balance assessment apply to the storm water management design. Please refer to Section 6.2.4.

The above assumptions act as limitations in the design. A specific risk is the assumption pertaining to the rate of rehabilitation. Ongoing monitoring during construction is required to ensure that rehabilitation areas are completed timeously. A second risk of the design is the assumption that the recommended construction sequence shall be adhered to. During detailed design, the order of implementation should be emphasized and included in the planning activities.

## 7.9 Catchment Delineation and Characterisation

The site sub-catchments can be broadly categorised as clean, contaminated and rehabilitated. Runoff from a catchment is considered clean when no pollutants have entered the flow, and contaminated is where the flow has been in contact with pollutants. Pollutants include chemicals such as salts from the ash and suspended solids, such as dust or ash particles.

- The clean sub-catchments include only areas of undeveloped, vegetated, natural veld.
- The contaminated sub-catchments include the active ashing area and the area that is in the process of being rehabilitated (referred to as the pre-rehab area).
- The conveyor corridor surface progresses along the crest of the NAGDF for its entire life, and it will only be rehabilitated once the facility is closed. It is formed from compacted ash, and is thus more impervious than the placed ash. It forms part of the contaminated sub-catchments.
- In addition to the operational areas, the contaminated sub-catchments will include the area that has been lined ahead of the active ashing area. This is the area where the liner has been installed (including the LCS) but ash has not yet been placed. It is highly impervious. The extent of the lined area, ahead of ashing will be limited to a 2- year area, to protect the liner from various potential risks such as sun exposure and mechanical damage.
- To the west of the lined area, a further 2-year area will be stripped of vegetation in preparation of liner placement and will also form part of the contaminated sub-catchments. Although it is not expected that there will be any contaminants present in this area, the probability of higher sediment content in the runoff, emanating from the catchment, will warrant the containment of this water within the dirty water system. The runoff volumes will increase due to removal of vegetation and thus need to be managed.
- The NAGDF will advance to where the ECSY is currently operational. Prior to the placing of ash, the area will have a nominal layer of coal remaining, over a lined system. Surface runoff from this sub-catchment will be contaminated.
- The rehabilitated sub-catchments are the vegetated, closed portion of the ash body. These areas are assumed to generate clean surface runoff on the basis that the vegetation is fully established, and continuous coverage of the entire surface has been reached, and that the vegetation anchors the soil to the surface, preventing erosion. It is also assumed that the vegetation is irrigated by rain water

and therefore will not introduce pollutants into surface flows through contact with direct rainfall.

The sub-catchments change and move as the facility progresses. Their parameters are summarised in Table 7-2 below:

**Table 7-2: Sub-catchment surface characteristics**

Sub-catchment type	% Impervious	Roughness factor (Impervious)	Roughness factor (Pervious)	Depression Storage, Impervious (mm)	Depression Storage, Pervious (mm)	SCS Curve Number	Runoff Quality
Veld	0		0.13	2.54	5.08	68	Clean
Ash	0		0.05	2.54	2.54	60	Dirty
Conveyor Corridor	30	0.02	0.05	2.54	1.27	60	Dirty
Lined	100	0.012	0.1	1.27	0.05	0	Dirty
Pre-Liner	0		0.05	2.54	2.54	0	Dirty
ECSY	100	0.01	0.05	2.54	5.08	0.6	Dirty
Rehab'd	0		0.15	2.54	5.08	65	Clean

The phases were modelled such that the most severe scenario was simulated for each PCD i.e. maximum contaminated catchment discharging to the PCD. The assignment of catchments to PCDs is as per the water balance assessment (see Figure 6-4). The catchments can be seen in Figure 7-2; Figure 7-3 and Figure 7-4.

## 7.10 Storm Water Collection and Drainage Infrastructure Sizing

Each phase is described in terms of the type of sub-catchments, the direction of flow of water and sizing of conveyance structures for contaminated storm water management. The rehabilitated NAGDF's storm water management system is covered separately in Section 7.10.5.

### 7.10.1 Year 4 to 8

During the years of life 4 to 8, the approach ramp will be completed, shaped, and rehabilitation will start as the NAGDF advances past the year 4 marker to its initial full height of approximately 64 m (increasing at a slope of 1:300 to a height of 72 m in year 20).

#### *Ash Sub-catchments:*

It has been conservatively assumed that the 0 to 4 year area will only start being rehabilitated once the ash placement has progressed past the year 4 area. Thus, prior to rehabilitation, the entire approach ramp of approximately 750 m width, and the side slopes of the ash, will be exposed – approximately 95 hectares of contaminated catchment. In addition, these catchments would all be relatively steep. The side slopes of the shaped ash have a slope of 20 %, and the approach ramp 5 %. Large runoff volumes from this area are therefore anticipated. This case was identified as the critical scenario for this phase and was modelled.

Runoff from the shaped landform will flow over the ash directly into the perimeter contaminated storm water trenches. These trenches are to be installed as part of the year of life 0 to 4 construction plans.

The conveyor corridor runoff drains to two drop boxes and then via buried pipe into the eastern perimeter trenches.

The northern half of the shaped ash and conveyor corridor will report to Dam D1, and the southern half to Dam D2. A small percentage of the northern portion will report to Dam D2B. This division in the catchment is to accommodate the topography of the site as a ridge runs diagonally through this area of the footprint.

*Lined and Pre-lined Sub-catchments:*

Further to the ash area, the 4 to 6 year area will be lined, and the 6 to 8 year area stripped of vegetation in preparation of liner placement. The northernmost quarter of these two sub-catchments will report to Dam D2B and the remainder to the proposed new Dam D3.

It should be noted that contaminated storm water trenches and PCDs should be constructed and operational prior to the vegetation clearance and stripping of the area for liner placement. For this phase, this means that the northern perimeter drain is required to be extended and a contaminated trench installed along the southern boundary, to convey flows into the Dam D3 Complex.

It is imperative that the separation walls and boundary berms of the area be constructed at the beginning of the clearance process in the lined and pre-liner areas. The boundary berm refers to the berm at the north and south boundaries of the facility footprint and the separation wall refers to at the border of each 2-year area. This would include installation of the leachate outfall pipes to the boundary berm, to enable flow into the contaminated storm water trench. In addition, in the pre-liner area temporary installation of an outfall pipe (a concrete sleeve would be adequate) midway along the boundary berm would be required. The berms will act as an upslope cut-off berm and will provide storage space for runoff volumes to pond, and be attenuated before throttled release through the leachate outfall pipes into the perimeter storm water trenches. This is beneficial in that the peak of the extreme event is reduced and sediment has an opportunity to settle out before entering the conveyance system. Although the silt will need to be monitored and removed if necessary, the quality of water entering the storm water system is improved and prevents downstream clogging of trenches, filling of silt-traps and sedimentation in PCDs.

In the 4 to 8 year areas, the natural ground slopes towards the south-west. Thus, ponding of surface flows against the separation wall, in the corner will occur. It is therefore recommended that both the lined and stripped area be provided with smaller lateral berms, of approximate height 1.0 m and length 200 m, at intervals along the southern boundary, perpendicular to the edge berm to provide capacity for temporary storage of the storm water runoff and to prevent uncontrolled overflow into the dirty water trench. This system of edge berm with outfall pipes and cascading lateral berms (named so as the water will pond behind one berm, then cascade around in and flow into the next berm) will only be in effect temporarily, before the placing of ash. If not installed, the following undesirable occurrences may result:

- excessive ponding;
- inhibition of liner placement activities;
- surface erosion;
- peak flows overtopping storm water management infrastructure; and
- damage to the liner.

*Storm Water Modelling Outcomes:*

The following outcomes of the storm water simulation for 1:50 year 24-hour rainfall event for the most critical scenario for years of life 4 to 8 were determined:

- All contaminated storm water trenches designed for the year of life 0 to 4 phase are adequate to convey the flows.
- The conveyor corridor drainage trenches, drop boxes and piped outlets are adequate to convey the flows.
- Northern perimeter trenches: The existing trench is adequate to convey flows. It is recommended that this trench be extended approximately 500 m to the west (though still draining to Dam D2B) with a 'N1' profile as per 0 to 4 year design, with the side-slope of the trapezoidal section decreased to 1:2 from 1:1,5. (refer to drawings B754-00-008 and -009 – Eskom Ref: 0.84/19380&1). This section has a depth of 0.8 m and an invert width of 0.6 m.

Currently, the channels are specified to be lined with cement stabilised soil-infilled geocells. This lining is not ideal for this application as the durability of the cement stabilised soil has proved to have limitations. It is therefore recommended that concrete-infilled geocell lining be used, over the impermeable HDPE liner.

It must be noted that experience from the construction of the Excess Coal Stockyard has deemed trenches with sideslopes of 1:2 easier to construct than 1:1.5. Thus, all storm water trenches have been changed to 1:2.

It is important to note that the capacity of these trenches to accommodate the storm assumes that the temporary edge berm with outfalls and lateral berms system, as discussed above, has been implemented.

- Southern perimeter trenches: A new trench will be required to capture contaminated surface runoff flows from the 4 to 8 year area, which will be lined and stripped. The trench shall be trapezoidal in section, with side slopes of 1:2, depth of 0.75 m and an invert width of 1.0 m. The lining will be concrete-infilled geocells, underlain by an impermeable HDPE liner.

Again, the capacity of these trenches in this phase is sufficient assuming that the temporary storage system within the footprint is in place.

- Construction of Dam D3 Complex. Dam D3 to have 0.8 m of freeboard and a 5.0 m wide spillway.
- Placement of cascading lateral berms on lined area (years of life 4 to 6).
- Placement of cascading lateral berms and installation of temporary outfall pipe to boundary berms on pre-lined area (years of life 6 to 8).

#### 7.10.2 Year 8 to 12

During the course of years of life 8 to 12, the approach ramp will be rehabilitated. The rehabilitation will continue three shifts behind the active ashing area. The ash will progress up to year 8. Years 8 to 10 will be lined, and 10 to 12 will be stripped of vegetation in preparation of liner placement.

##### *Ash Sub-catchments:*

The contaminated ash sub-catchment area will be half of that in the previous phase because of concurrent rehabilitation, at a maximum width of approximately 300 m, with an associated area of 48 hectares. The northern half of the ash will drain to Dam D2B, and the southern half to Dam D3.

As for the previous phase, the pre-rehab shaped ash body, which will have a width of three shifts (180 m) will drain directly into the perimeter storm water trenches, from its 20 % side slopes.

The ash & gypsum body in the active disposal area will be placed but not shaped, and will thus have side slopes of 1:1,5, or 67 % which is the angle of repose of the material. A stretch of approximately 105 m of lined area needs to be left available for the shaping of the ash to its final side slope of 1:5 (or 20 %). Surface runoff from the ash body will pond in this area and be attenuated, entering the storm water system through the liner drainage system. The lateral berms constructed for the pre-ash phase should be left in place, as they will assist with portioning the water which serves to provide additional temporary storage capacity and prevent deep ponding from occurring at low points.

The conveyor corridor will be drained as described above. The northern half of the conveyor corridor will report to Dam D1, and the southern half to Dam D2. As the corridor extends, its catchment will increase and the volumes reporting to these PCDs is anticipated to increase.

*Lined and Pre-lined Sub-catchments:*

The entire lined and stripped area will report to Dam D3. These areas are required to have the temporary storage system as described above in place to manage large runoff volumes during rainy period.

*Storm Water Modelling Outcomes:*

The following outcomes of the storm water simulation for 1:50 year 24-hour rainfall event for the most critical scenario for years of life 8 to 12 were determined:

- The northern contaminated storm water trench will only receive runoff from the ash area therefore the extension constructed during the previous phase will be adequate to convey the flows, and the length of the trench does not need to be modified in this phase.

However, the capacity of the existing northern trenches was found to be insufficient to convey the storm event without overtopping. It is therefore recommended that these trenches have their depth increased to 1.2 m.

- The southern perimeter trapezoidal trench constructed in the previous phase with side slopes of 1:2, depth of 0.75 m and invert width of 1.0 m will be adequate for management of runoff from the ash area (both active disposal and pre-rehab).
- New trenches shall be required in the south to capture runoff from the lined and stripped areas and convey the flows to the Dam D3 Complex. These will have the same sizing as the trenches mentioned above. This sizing is in excess of the capacity requirements for this phase, but will come into full use in the following phases where runoff from the shaped ADF is received.

### 7.10.3 Year 12 to 20

*Ash Sub-catchments:*

During years of life 12 to 20, the ADF will advance and cover what is currently the Excess Coal Stockyard. This area is already lined, and this existing lining system will capture seepage flows from the ash body, and runoff prior to ash placement. The final toe of the NAGDF will coincide with the edge of the ECSY lining system. The lining system terminates before the paddocks, although the paddocks do have clay liner to contain them. These paddocks will remain in place for the NAGDF and will become an integral part of the storm water management infrastructure, Runoff from the ash face, once shaped, will collect in the paddocks before draining to the contaminated storm water trenches. This is advantageous as the peak flows will be reduced and the existing trenches will have capacity to convey the runoff.

Perimeter trenches will be required to be extended around the advancing facility, and will tie into the existing ECSY trenches servicing the western and southern sides of the ECSY. Contaminated runoff will report to Dam D3B and the existing ECSY PCDs .

*Excess Coal Stockyard Sub-catchments:*

A nominal layer of coal will remain over the liner of the ECSY once all coal has been reclaimed. Surface runoff from these areas, prior to ash placement, will be contained within the edge berms and existing paddock system before infiltrating into the leachate systems and being discharged into the storm water trenches.

*Storm Water Modelling Outcomes:*

The following outcomes of the storm water simulation for 1:50 year 24-hour rainfall event for the most critical scenario for years of life 12 to 20 were determined:

- New trenches will be required in the south and north to capture runoff from the NAGDF and convey the flows to Dam D3B in the north, and planned PCDs D6, D7 and D8 in the south. These trenches will be trapezoidal, with side slopes of 1:2, a depth of 0.75 m, and an invert width of 1.0 m.
- Construction of Dam D3B. Dam D3B to have 0.8 m of freeboard and a 5.0 m wide spillway.

#### 7.10.4 Summary of phased storm water infrastructure works

See Table 7-3 below summary of work required at each development phase of the NAGDF.

**Table 7-3: Phased contaminated storm water management works**

Phase	SW Infrastructure	Works Required
Year of life 4	Northern trench	Construct 500 m extension, depth of 0.6 m, invert width of 0.8 m and side slopes of 1:2. Drains to Dam D2B.
	Southern trench	Construct new trench, depth of 0.75 m, invert width of 1.0 m and side slopes of 1:2. Drains to Dam D3.
	Cascading lateral berms	Construct 10 of 100 m long, 1.25 m high with 1:3 side slopes. Install 3 of temporary outfall pipes to boundary berms.
	Dam D3	Construct.
	Dam D3B	N/A
Year of life 8	Northern trench	Increase depth from 0.6 m to 1.2 m.
	Southern trench	Construct new trench, depth of 0.75 m, invert width of 1.0 m and side slopes of 1:2. Drains to Dam D3.
	Cascading lateral berms	Construct 10 of 100 m long, 1.25 m high with 1:3 side slopes. Install 3 of temporary outfall pipes to boundary berms.
	Dam D3	N/A
	Dam D3B	N/A
Year of life 12	Northern trench	Construct new trench, depth of 0.75 m, invert width of 1.0 m and side slopes of 1:2. Drains to Dam D3B.
	Southern trench	Construct new trench, depth of 0.75 m, invert width of 1.0 m and side slopes of 1:2. Drains to Dam D3B.
	Cascading lateral berms	N/A
	Dam D3	N/A
	Dam D3B	Construct.

#### 7.10.5 Clean Water Management Infrastructure on Rehabilitated NAGDF

The proposed rehabilitation will include the following activities:



- Cut to fill of side slopes: angle of 34° (1[v] to 1.5[h]) to an average angle of 11.3° (1 to 5);
- Cover facility surface area with 300 mm topsoil;
- Scarification and fertilization of the topsoil layer;
- Grassing of topsoil area including pioneer and long term grass seeding;
- Transplanting of existing and new trees and shrubs;
- Irrigation;
- Installation of storm water measures including down-chute pipes, outlet channels, energy dissipaters, side slope berm trenches, shift berms and crest berms.
- Maintenance of rehabilitated area.

#### *Rehabilitation Storm Water Management on Top of the NAGDF*

Runoff emanating from the top of the NAGDF will be directed, by means of a series of berms and v-drains, to geocell lined canals on top of the NAGDF. These canals will subsequently drain to the next 825 mm diameter down chute pipe where there will be an inlet allowing water to enter the pipe and for discharge into the environment via an energy dissipater. Rehabilitation shift berms will be located every two shifts. These will have two functions:

- Direct water from the associated catchment to the canals on top of NAGDF canal.
- Separate the area that is to be rehabilitated (the pre-rehab area) from the active ashing area.

While an area is in the process of being rehabilitated (i.e. the pre-rehab area) it will continue to drain to the dirty water system. However, berms should be constructed between the active ashing area and the area being rehabilitated, such that the dirty water generated from the ashing area does not flow onto the area currently being rehabilitated and compromise the effectiveness of the rehabilitation.

The rehabilitation shift berms will be 1.0 m high and crest widths will alternate between 1.0 m or 4.0 m. These will be constructed on the top of the NAGDF at each two shift area, with a 1.0 m wide berm continuing down the side-slope every four shifts, to coincide with the rehabilitation down-chute pipes. These berms will be located to the east of the rehabilitation pipes in order to demarcate and separate the different side slope areas. The 4.0 m wide berms will be for vehicular access and will occur every two years, alternating with 1.0 m wide berms, as described above. The top of the facility will be bounded by a 1.0 m high, 4.0 m wide access berm that will allow vehicular access to the rehabilitated areas. These will be extended as an area is rehabilitated and constructed to tie into the previous areas' rehabilitation shift berms.

#### *Rehabilitation Storm Water Management on Side Slopes of the NAGDF*

To manage water generated on the side slopes of the NAGDF a series of bench berms at contour intervals of 10 m will be constructed. The purpose of these berms is to divide the side slope of the NAGDF into sections which minimise the overland flow length down the side slope, thereby minimising the risk of erosion. Storm water running off the side slopes will be conveyed along the berm, at a longitudinal slope of 1:100, to the rehabilitation down-chute pipes. At each intersection of the berm and the pipe there will be a drop inlet structure that will allow water to enter the pipe from the bench berms. The pipes will

subsequently convey the water down the side slope of the facility and discharge the water into the environment, via an energy dissipater.

#### *Release of Clean Runoff from Rehabilitated NAGDF*

Energy dissipation will be facilitated by use of a stilling basin with a stone-pitched concrete outlet apron at its exit. Rip rap shall be placed on the soil between the concrete apron and the natural ground to prevent scour beneath the toe of the apron and protect the natural soil. The flow from the collector pipe is predicted to enter the stilling basin at a velocity of approximately 9 m/s for the 1:50 year storm event. The stilling basin will decrease the flow velocity by approximately 60 % to less than 4.0 m/s. The water will then flow over the outlet apron to further dissipate energy and assist with the transition from concentrated pipe flow to overland flow.

Next to proposed Dam D3, no collector pipe will be installed as its outlet would interfere with the dam. The rehabilitated catchment will then outlet to the neighbouring collector pipes. The crest drains will tie into the collector pipe at approximately the 4-year mark. A culvert under the crest access road will be required. The side slopes adjacent to Dam D3 will be sloped to drain to the collector pipe at approximately the 10-year mark. In this way, the runoff volumes are divided between collector pipes and outlet locations, enabling the typical section of an 0.825 m diameter concrete pipe specified to be sufficient to handle the flows without choking.

#### *The Effect of Rehabilitated NAGDF Runoff on Transnet Infrastructure*

As mentioned in Section 5.2, the Transnet railway line traverses the Sandloop catchment, hindering free surface flow in a southerly direction. The railway embankment is fitted with pipe culverts, estimated by visual inspection to have a diameter of between 800 mm to 1000 mm, at approximately 800 m intervals. The intention is that clean water released from the rehabilitated NAGDF storm water management system will flow freely over the undeveloped surface of the surrounding area and drain away following the natural topography. The runoff released on the south of the NAGDF will then intercept the railway embankment and drain through the culverts.

Overland flow from the outlets for the 1:50 year 24-hour storm event was assessed. The volume of runoff from the rehabilitated facility draining to these outlets would be in the order of 19 600 m<sup>3</sup> (worst case/largest catchment) for the 1:50 year 24-hour storm event. It was found that ponding would occur and the culverts would back up.

The ponding can be minimised by the construction of a V-drainage trench adjacent to the eastern and western sides of Dam D3. Either a culvert or a drift feature shall be required to be fitted to the service road next to the railway culverts to accommodate the flows without erosion or sedimentation taking place. During detailed design, the sizing and invert levels of these drains should be sized based on Lidar survey and the final layout of the service road. Site measurements of the size and invert levels of the railway culverts should be taken to enable alignment of outlet drains with them.

In order to prevent pooling even in extreme events, V-drain dimensions of depth = 2m, width = 5 m will need to be installed to channel rehab water to a larger culvert with a diameter of 2 800 mm. It is also recommended that the inlets and outlets of the culvert be formalised by the installation of pre-cast concrete wing-walls.

#### *Rehabilitation of PCDs and Contaminated Storm Water Management Trenches*

Energy dissipation will be facilitated by use of a stilling basin with a stone-pitched concrete outlet apron at its exit. The flows are slowed down by drop boxes within the collector pipes

on the side-slopes of the NAGDF, and are predicted to enter the stilling basin at a velocity of approximately 2.5 m/s for the 1:50 year storm event. The stilling basin will decrease the flow velocity by approximately 60 % to less than 1.0 m/s. The water will then flow over the outlet apron, which will be concrete fitted with stone-pitching to further dissipate energy and assist with the transition from concentrated pipe flow to overland flow.

The PCDs and contaminated storm water trenches will remain open and operational until the leachate seeping from the NAGDF has reduced to insignificant volumes. At this time, the, contaminated water remaining in the PCDs shall be removed by pumping to storage in a suitable location (either sent off-site for stabilising or relocated to operations within the power station). The PCD's shall be filled and covered with suitable material.













The PCDs shall be replaced with manholes of large enough capacity to collect leachate volumes. These volumes shall be monitored and removed periodically. When the time comes that leachate volumes are negligible, the leachate collection pipe outlets shall be sealed and closed with concrete, and the storm water trenches infilled and covered with suitable material.

At conceptual stage, it is not possible to estimate how long these periods will be and continuous monitoring during operations shall be required to achieve effective management of contaminated flows of the closed facility.



Note:  
All undeveloped, natural veld areas are clean and assumed to be free draining

**Legend**

-  Berms
-  FlowDirection
-  Outfalls
-  Storages
-  Spillways
-  Contaminated SW Trenches
- Subcatchments**
-  Ash
-  Conveyor Corridor
-  Lined
-  Pre-Liner
-  Sand Roads
-  Veld

Coordinate System: Hartebeesthoek94 Lo27

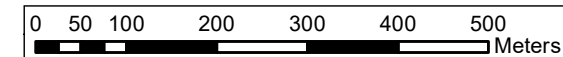



Operational Ashing Area, 114 m wide



Shaped Ash, Pre-Rehab, 180 m wide

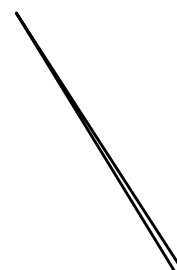

Note:  
All undeveloped, natural veld areas are clean and assumed to be free draining

**Legend**

- TAG**
- 1m Backstack Berm
  - 4m Backstack Berm
  - 4m Crest Berm
  - Collection Pipe
  - Dirty SW
  - Outfall Pipes
  - SW Bench Drain
  - SW Toe Trench
  - SW Toe Trench Outlet
  - Contaminated SW Trenches
  - Flow Direction
  - Outfalls
  - Storages
  - Spillways
  - Cascading Lateral Berms
- Subcatchments**
- Ash
  - Rehab
  - Conveyor Corridor
  - Lined
  - Pre-Liner
  - Sand Roads
  - Veld

Coordinate System: Hartebeesthoek94 Lo27

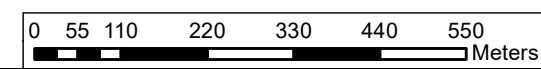

**ESKOM - MEDUPI POWER STATION**  
**Ash Disposal Facility Years 4 to 20 - Storm Water Management Plan**  
**8 to 12 Year Storm Water Management Plan**



















Job No: G145-302

Figure 7-3



Note:  
All undeveloped, natural veld areas are clean and assumed to be free draining  
Flow direction arrows in ECSY sub-catchments indicate flow on NADF during phased development

### Legend

-  FlowDirection
-  Outfalls
-  Storages
-  Spillways
- Conduits**
-  1m Backstack Berm
-  4m Backstack Berm
-  4m Crest Berm
-  Collection Pipe
-  SW Bench Drain
-  SW Toe Trench
-  SW Toe Trench Outlet
-  Dirty SW
- Subcatchments**
-  Ash
-  ECSY
-  Rehab
-  Conveyor Corridor
-  Sand Road
-  Veld

Coordinate System: Hartebeesthoek94 Lo27

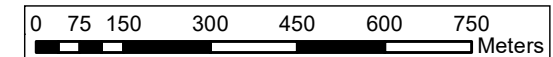

### 7.11 Water Quality Management (Desilting)

Silt traps are provided at each of the proposed dams to prevent the dams from silting up. The dams and their associated silt traps should also be regularly cleaned out so that their capacities are not compromised.

The size and geometry of each silt trap is a function of hydraulic inflow and sediment size distribution flowing into it, as well as the hydraulic outflow from the silt trap. Determination of the design criteria for the silt traps, including particle size and flow will need to be carried out during detailed design phase.

During concept design, proposed PCDs Dam D3 and Dam D3B have been laid out to include silt traps. The most suitable locations for the proposed silt traps have been identified based on available space, geometric constraints and topography of the site. This ensured that space is allocated for silt traps and contaminated storm water trenches can drain to the silt traps.

### 7.12 Erosion Protection

Erosion protection in the form of stilling boxes and riprap stilling basins will be provided where required to prevent erosion and silt entering into the clean water system.

### 7.13 Access to the NAGDF Footprint

During the development of the NAGDF, access is required from the surrounding roads into the footprint by heavy-weight vehicles. As the storm water trenches are constructed concurrently with ash stacking progression, access into the footprint will be from ahead of the storm water trench. Thus, no culverts are required during years of life 4 to 12.

When year of life 12 is reached, the NAGDF advancing face will intercept the existing ECSY. At this point perimeter trenches will encompass the entire footprint. It is recommended that the high point at the north-eastern corner of the ECSY, where the access ramp is planned, be kept as an access point. As this is a high point in the topography at a surface elevation of approximately 916 mamsl, the trenches servicing the NAGDF will fall from this point in either direction. To the east the new trenches linking to proposed Dam D3B will be installed, and to the west the existing trenches from the ECSY will continue to operate. This approach mitigates the need for the installation of a culvert to the perimeter storm water system.

Once rehabilitated, access to the surface of the facility will be from the eastern starter platform only. No other roads will be required within the footprint.

## 8. ASH GROWTH PLAN

### 8.1 Assumptions

The following assumptions were made pertaining to the Medupi NAGDF growth plan:

- Ash generation rate of 136.28 tons/hour/unit and ash density of 800 kg/m<sup>3</sup>
- Gypsum generation rate of 51.33 tons/hour/ unit and gypsum density of 1000 kg/m<sup>3</sup>
- The first 10 shifts are spaced 66 m apart, thereafter the shifts change to being 60 m apart
- Total number of shifts increased from 55 to 59

- The power station will also incorporate wet limestone flue gas desulphurisation (FGD) technology which will be retrofitted after 6 years of commissioning. Table 8-1 details the unit commissioning dates and volumes that were used:

**Table 8-1: Unit commission dates and associated volumes generated**

Unit	Unit commissioning (excluding gypsum)		Unit commissioning (including gypsum)		Eskom Unit Designation
	Commissioning date	Volume (m <sup>3</sup> /month)	Commissioning date	Volume (m <sup>3</sup> /month)	
1 <sup>st</sup>	01/08/2015	124 355.5	30/07/2021	783 603.9	Unit 6
2 <sup>nd</sup>	30/01/2016	248 711.0	28/01/2022	821 074.8	Unit 5
3 <sup>rd</sup>	31/07/2016	373 066.5	30/07/2022	858 545.7	Unit 4
4 <sup>th</sup>	29/01/2017	497 422.0	28/01/2023	896 016.6	Unit 3
5 <sup>th</sup>	31/07/2017	621 777.5	30/07/2023	933 487.5	Unit 2
6 <sup>th</sup>	29/01/2018	746 133.0	28/01/2024	970 958.4	Unit 1

- After 28/01/2024, a constant generation rate of ash and gypsum together of 970 958.4 m<sup>3</sup>/month/unit is utilised
- From Shift 1 to 36 both the northern and southern stackers progress together placing an equal quantity of the ash and gypsum volume (50% split)
- After Shift 36, the northern stacker and southern stacker will move independently due to the difference in geometry.
- If the two stackers are to reach the end of the disposal facility at the same time (within a 2 week accuracy) then a utilisation split of 62%:38% for the northern and southern stacker will be required respectively.
- After Shift 36, the southern stacker will progress in radial shifts. Assuming a shift length of 426.3 m from Table 3-5 and shift width of 60 m, this results in 11 radial shifts.
- Hereafter, the remainder of the 14 206 777 m<sup>3</sup> of material to be place on the southern portion of the footprint will be place by a load and haul operation.

## 8.2 Growth plan

The following growth plan is based on the information provided above. A detailed shift frequency plan has been included in Appendix C. A growth plan consists of three graphs:

- Time Vs. Chainage: This graph indicates at what point in time the facility will reach a specific chainage.
- Volume Vs. Time: This graph indicates at what point in time the facility will reach a specific volume.
- Volume Vs. Chainage: This graph illustrates the relationship between the volume of the facility and its development in space.



Where power station units are referred to in the graphs, unit 1 represents the first unit commissioned and no reference to the Eskom designated unit name is used (i.e **Unit 6** being commissioned first).

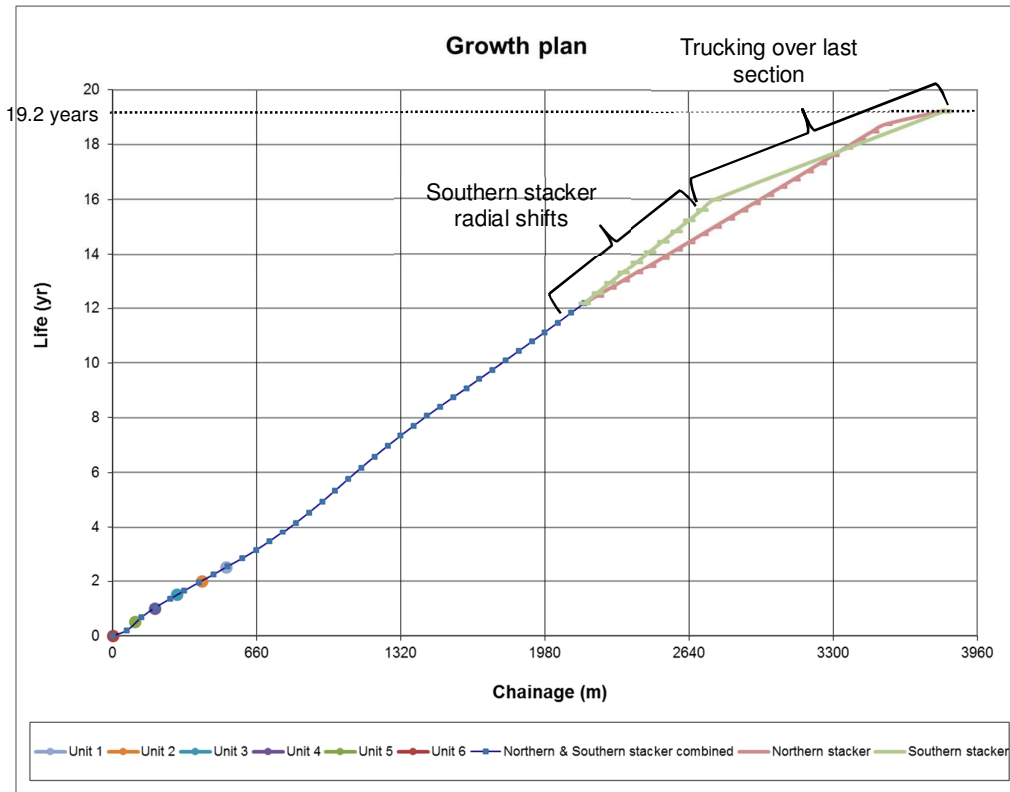

Figure 8-1: Growth plan – Time vs. Chainage

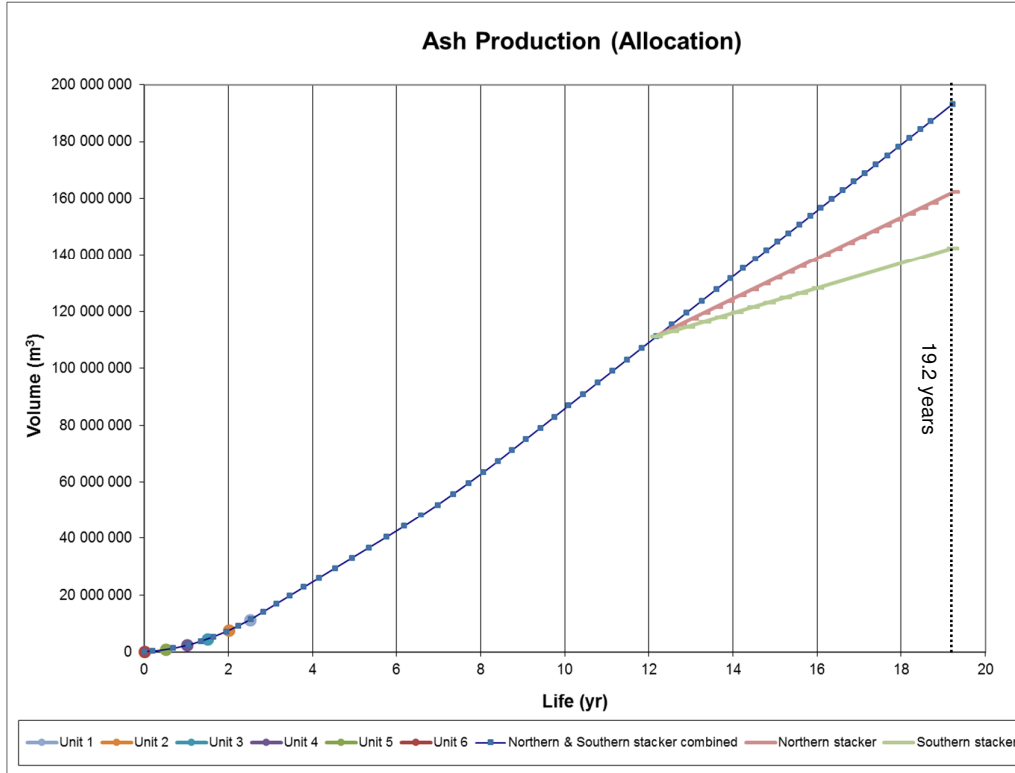

Figure 8-2: Growth plan – Volume vs. Time

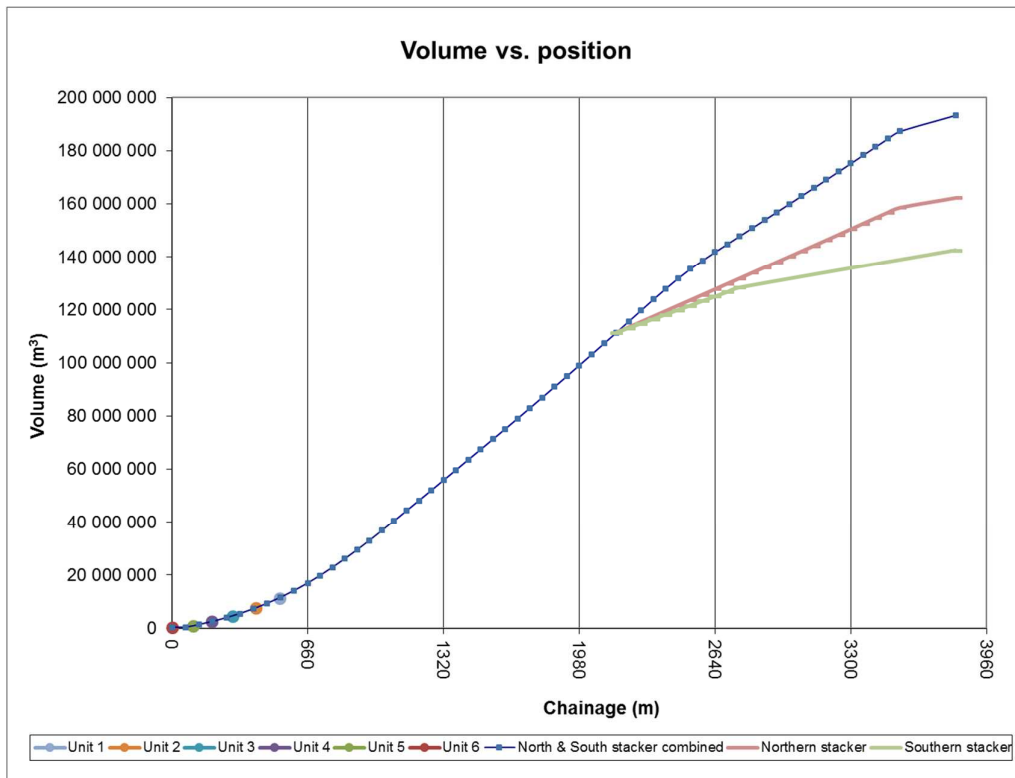

Figure 8-3: Growth plan – Volume vs. Chainage

The chainage at which the 4 year lined areas were originally defined were kept due to alignment of the 12 year edge falling along the proposed edge of the ECSY. Hence, the areas' naming is not completely accurate with regards to the indication of the storage life. Table 8-2 details the shift, chainage, cumulative volume, actual life and the stacking commencement date of these "4 year" lined areas.

**Table 8-2: Details of 4 year lined areas**

4 year lined areas	Shift No.		Chainage		Cumulative volume (m <sup>3</sup> )	Actual Life (years)		Commencement date
	From	To	From	To		From	To	
0 – 4 year	1	11	0	827	23 545 050	0	3.9	01/08/2015
4 – 8 year	11	23	827	1 563	68 871 050	3.9	8.6	21/06/2019
8 – 12 year	23	36	1 563	2 348	121 558 772	8.6	13.1	29/02/2024
12 – 16 year	36	48	2 348	3 089	162 369 648	13.1	16.3	27/08/2028
16 – 20 year	48	end	3 089	3 800	193 315 105	16.3	19.2	15/10/2034

The General Manager of the Medupi Power Station sent out correspondence on 12 September 2017 stating "Using coal burn assumptions in line with the current Unit performance trends, the international model predicts that the excess coal stockyard will be depleted by July 2024. The facility will only reach the start of the excess coal stockyard footprint by November 2030. When low load factors are input into the model for both Medupi and Matimba, the stockyard reclamation dates move out to June 2027, with the facility only reaching this position in March 2031."

Looking at Table 8-2 it shows that the facility will reach the edge of the ECSY end of August 2028 which is two years earlier than the earliest date mentioned above. Therefore, it must be noted that the edge of the ECSY (end of 12 year lined area) may be a juncture of the end of ash-gypsum disposal capacity if the ECSY is not reclaimed timeously. At this point, a combined ash and gypsum volume of 121 558 772 m<sup>3</sup> will have been disposed.

It is recommended that the coal reclamation philosophy consider, if possible, reclaiming coal in an east to west direction. Drawing G145-405-005 illustrates a long section where the ash is placed above the coal.

Considering the commencement dates in the table above and assuming that a period of two years is required for the construction of the next 4 year lined area, the construction commencement dates have been detailed in Table 8-3 below. Since the 12 year edge falls along the proposed edge of the ECSY, the area beyond this point to the end of the Ash & Gypsum Disposal Facility (20 years) will already be lined except for two small areas. One small triangular area on the south eastern corner of the 12 to 16 year area and a long rectangular area to the northern of 12 to 16 year area. This combined area comes to 214 624 m<sup>2</sup> and will need to be lined at the end of the 8 to 12 year area – see Figure 3-4. The liner design of the ECSY is currently being upgraded to a Class C liner hence no further liner upgrades will be required at the interface between the NAGDF and the ECSY when the 8 to 12 year area is constructed. However, there will be some infrastructure upgrades required as discussed in Section 7.

It must be noted that the ideal time to start construction of the 4 to 8 year area was in June 2017.

**Table 8-3: Commencement of construction of 4 year lined areas**

4 year lined areas	Ideal construction commencement date
4 – 8 year	21/06/2017
8 – 12 year	29/02/2022
12 – 20 year	27/08/2026

**8.3 Topsoil management**

Figure 8-4 shows the method of progressive topsoil management. The topsoil of the first 4 years lined area was stockpiled for later use in the 4 to 8 year area. This material will need to be used for the rehabilitation of some of the first 4 year area and the remainder stored for future requirements.

The graph shows that there should be sufficient topsoil on site to rehabilitate the facility. If there is a deficit near the end, topsoil will need to be supplied from a commercial source of topsoil.

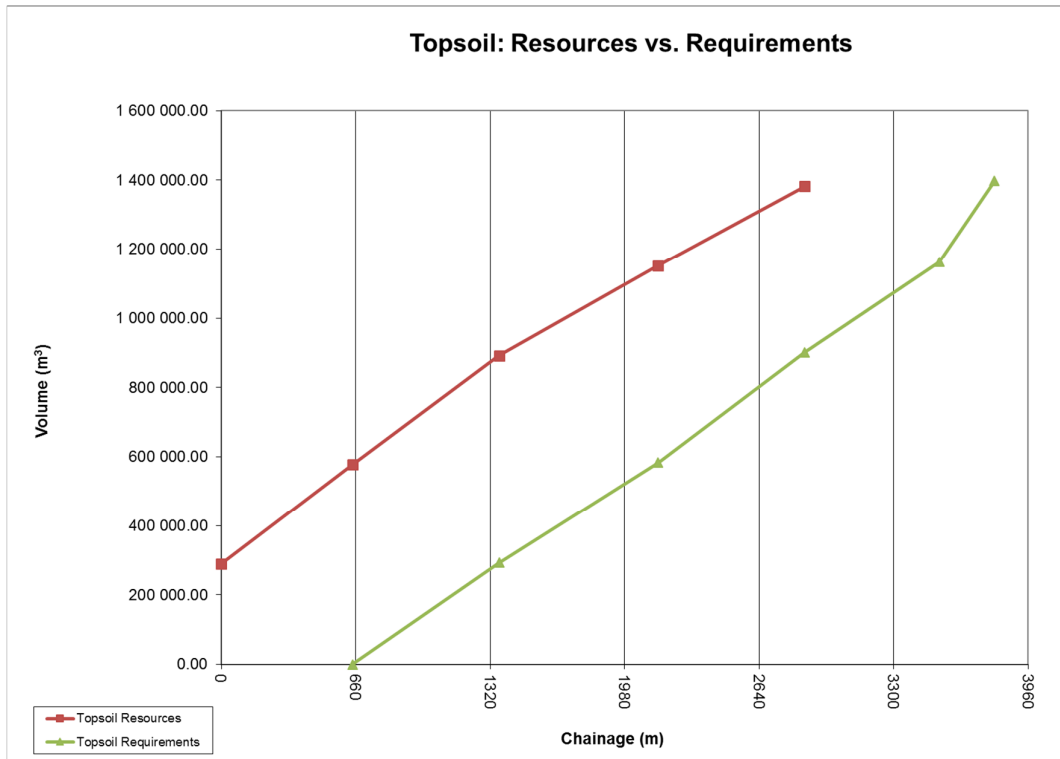

**Figure 8-4: Topsoil – Resources vs. Requirements**

**9. LIFE CYCLE COST ESTIMATE**

**9.1 Assumptions**

The following assumptions were made pertaining to the Medupi NAGDF life cycle costing estimate:

- All the assumptions in Section 8.1 are still applicable and its growth plan was used as the basis of the life cycle cost estimate;
- As part of the design of the Medupi NAGDF it has been assumed that rehabilitation will occur three shifts behind the active ashing area, hence rehabilitation costs are only applicable from shift 4 onwards;
- The approach ramp plan area and side slopes will be rehabilitated between shift 4 and 20;
- The lining cost of the next 4 year area and associated PCDs have been assumed to be financed 2 shifts before the current 4 year area ends (Table 8-2);
- For the load and haul operation on the southern portion of the footprint the following assumptions were made:
  - 80% truck efficiency and an 8 hour a day operation;
  - Loading takes 7.5 minutes for a front end loader to fill a 30 ton ADT and the average round trip takes 26 minutes;
  - This results in the need for 3 loaders and 17 haul trucks (30 tons);
  - Further information and the Net Present Value of the load and haul operation has been included in Appendix D.
- Table 9-1 details the cost of operations and rehabilitation required over its life:

**Table 9-1: Operational and rehabilitation costs for facility**

Item	Cost
Extendable Conveyor	R 80 600.00 /m
Shiftable Conveyor (Parallel)	R 2 121 242.85 /shift
Shiftable Conveyor (Radial)	R 1 484 870.00 /shift
Sloped areas rehab	R 54.00 /m <sup>2</sup>
Inner slopes adjacent to extendable conveyors rehab	R 90.00 /m <sup>2</sup>
Plan areas rehab	R 36.00 /m <sup>2</sup>
Lining cost (Class C)*	R 400.00 /m <sup>2</sup>
Load (rate includes operator and diesel)	R 23 640.00 /day
Haul (rate includes operator and diesel)	R 133 280.00 /day
Rehabilitation of PCDs post power station operations	R 100.00 /m <sup>3</sup>
Rehabilitation of storm water canals post power station operations	R 150.00 /m

\*applicable to the NAGDF footprint and PCDs

- Rehabilitation of the PCDs and associated storm water canals for post power station operations will commence in a phased approach over the last 5 shifts of the NAGDF's life;

- The cost of these rehabilitation works, detailed in Table 9-1, allows for impairing the liner (to ensure adequate drainage) and backfilling the PCDs and storm water canals;
- Details on the volume of backfill for each dam and its associated length of storm water canal can be found in Appendix D.

A breakdown of the life cycle cost estimate has been included in Appendix D and the Net Present Value based on Eskom's Discount rate of 8.4% can be seen in Figure 9-1.

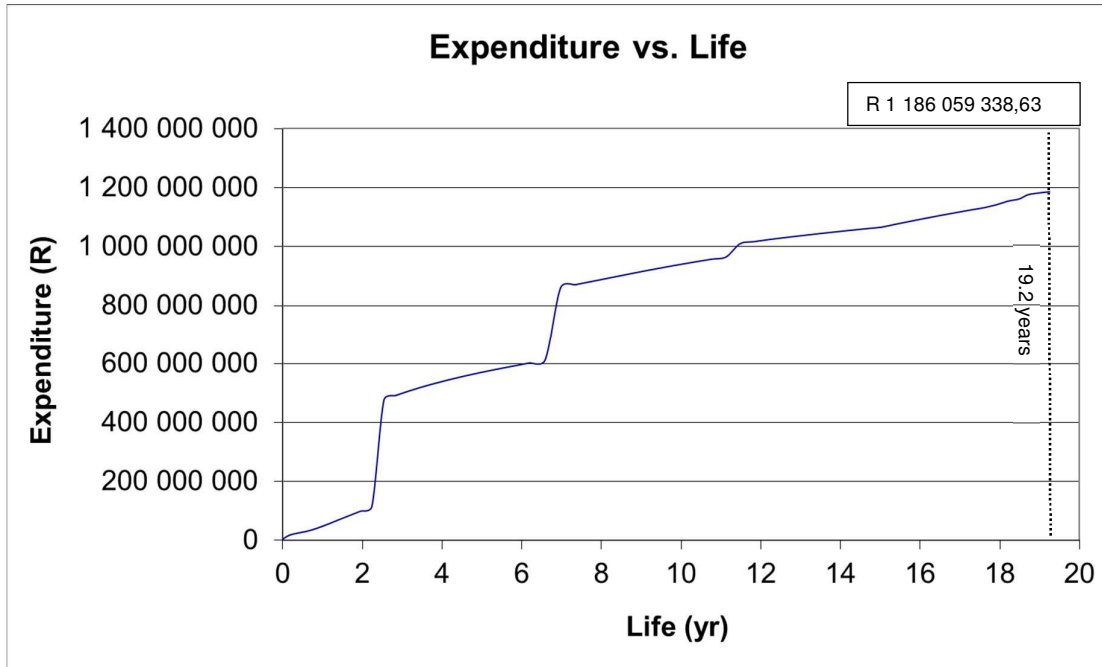

Figure 9-1: Life cycle cost estimate – Expenditure vs. Time

## 10. NORTHERN ASH & GYPSUM DISPOSAL FACILITY INFRASTRUCTURE

### 10.1 Material handling

The ash and gypsum will be transported to the facility through the existing overland, extendable and shiftable conveyors.

The extendable conveyors will need to be extended with each shift.

The shift positions are shown on drawing G145-405-001. The northern stacking system will contain 59 parallel shifts while the southern system will contain 36 parallel shifts followed by 11 radial shifts.

It will need to be confirmed during detail design stage that the extendible/shiftable conveyor transfer point interface can accommodate this radial shifting, especially during the last few radial shifts when a rather acute angle will result between the conveyors as this was not envisioned when the machines were designed for the original dump geometry and parallel shifting philosophy.

The last section on the southern side will be placed with a truck and haul operation from the end of the last radial shift position.

## 10.2 Access roads

The site entry gate will be on the north eastern side of the site. Leading from the gate will be the service roads along the conveyors and the security road that follows the fence around the site.

At certain points along the security road will become access roads that branch off toward infrastructure such as storm water trenches or pollution control dams.

There are three service roads: one on either side of the two conveyors and one that runs between the conveyors. The service roads along the conveyors lead to the starter and erection platforms and then onto the conveyor corridor on the facility.

Access to the rehabilitated back stacks of the facility will be from the northern or southern end of the starter platform and access roads are included on the northern and southern edges with crossroads every fourth shift.

The facility has an existing access and security road enclosing it on the northern, southern and eastern sides with the western side service road being on the original 12 year facility development stage, approximately 180 m east of the ECSY edge. This western service road will be covered when the 8 to 12 year area is constructed. At this stage, the southern access road will be extended to the west to tie into the access road at ECSY Dam 6 which continues around the western edge of the ECSY while the northern security road will be extended to join the current haul road for the ECSY. Currently, the road around the ECSY acts as both the security and access road but once the NAGDF reaches this area it will function as an access road and a new security road will be constructed along the western fence line.

Roads will be used for access to carry out maintenance, inspections, material delivery and construction.

## 10.3 Fencing

The facility is currently fenced off on the northern and southern sides adjacent to the sides of the facility leaving room for storm water management. The western side is fenced off at the original 12 year facility development stage, approximately 180 m east of the ECSY edge. This fence will have to be relocated when the 8 to 12 year is constructed.

The fence is included in the design to prevent unauthorized access. Signs indicating that there is an ash & gypsum facility on the property and that it is a safety risk area will be displayed.

## 10.4 Perimeter lighting

Lighting for perimeter security at Eskom installations (document identifier 240-91252455):

The perimeter security lighting must be divided into zones. Individual zones must be able to be switched on manually for testing and security purposes from the main gate security control room located in the Access Control Building.

Columns are placed at a minimum of 2,5 m distance from the fence line. The typical column spacing is between 25 and 30 m apart for general lighting. Columns for general lighting in a perimeter application are 8 m with lighting positioned at the top of the column.

Poles must be embedded in a solid concrete foundation measuring (500mm x 500mm x 600mm deep) of 35 MPa. Pole spacing must be calculated in accordance with the table in Annex B – for 8 m corridor width, spacing of luminaires is 22 m and mounting height of 6 m.

## 10.5 Other infrastructure

There are existing offices, stores, wash bay and materials laydown areas for the 0 to 4 year area as well as the ECSY. The 0 to 4 year infrastructure is located to the west of the 4 year separation wall and this will be moved ad hoc to the west as the 4 year areas develops. When construction of the 8 to 12 year area commences the infrastructure will be removed and the current infrastructure for the ECSY, situated on the north western corner, will be utilised.

## 11. ISSUES TO BE ADDRESSED IN THE DETAILED DESIGN

A meeting was held with the Department of Water and Sanitation (DWS) on 9 October 2017 for the approval of the concept design of the NAGDF. Minutes from this meeting can be found in Appendix E but the following points were raised which need to be addressed during the detailed design phase:

- The durability of the coarse ash drainage layer needs to be tested under the equivalent final load - the Los Angeles abrasion test was recommended. Also, the filter compatibility of sieved coarse ash drainage layer with the deposited ash under load should be investigated.
- The tests on the leachate produced from the disposal of the ash and gypsum needs to be undertaken to determine the effects on:
  - the permeability of the coarse ash drainage layer;
  - the permeability of the BES and
  - the durability of the geomembrane.

As site specific gypsum will not be available for some time, it is recommended that a synthetic gypsum be manufactured for the above tests as the best available option at the time.

- DWS advised testing with geomembrane coupons in 85°C ash/gypsum leachate could provide some answers to high pH and high salts impact on the liner, along with long term permeability testing of the BES with leachate which will be required.

Furthermore, during the process of the concept design for the NAGDF the following were identified as areas which need attention during the detailed design phase:

- The evaporation rates from the dams should be evaluated through an evaporation study to ascertain the extent to which the salinity of the water reduces the evaporation from the dams. If the results of the study show that the evaporation is different to that assumed in the water balance, the water balance will need to be revised.
- The water balance is an iterative process and is influenced by changes in design and site operations. Therefore, as the design progress and changes and moves into detailed design it is important that the water balance is updated and revised in conjunction with the design changes. It is our recommendation that the water balance be continually updated as the design develops, as well as through the operational period of the facility.
- Ponding against the railway can be minimised by the construction of a V-drainage trench adjacent to the eastern and western sides of Dam D3. Either a culvert or a drift feature shall be required to be fitted to the service road next to the railway culverts to accommodate the flows without erosion or sedimentation taking place. During detailed design, the sizing and invert levels of these drains should be sized



based on Lidar survey and the final layout of the service road. Site measurements of the size and invert levels of the railway culverts should be taken to enable alignment of outlet drains with them.

- The stacking operation after the southern stacker has completed the radial shifts can be optimised by assessing the following options:
  - using the northern stacker to place material in the south and dozing it across the footprint;
  - periodically extending the southern extendible conveyor to reduce hauling on the southern side;
  - using the link conveyor and crawler mounted stacker interfaced directly to the extendible conveyor.
- It will need to be confirmed that the extendible/shiftable conveyor transfer point interface can accommodate the radial shifting on the southern stacker system, especially during the last few radial shifts when a rather acute angle will result between the conveyors.
- Current pumping infrastructure does not have sufficient capacity to accommodate the maximum abstraction rates - a project/station decision will have to be made on the system upgrade.
- The SED methodology is based on currently stacked ash (February 2017 survey) which results in a conservative width. The methodology can be updated to be similar to the method used at Matimba Power Station once a similar profile in the ash & gypsum blend has developed.
- Shift width is not restricted by extendable conveyor module length. The modules can be modified to suit any shift width. This must be considered in the stacker optimisation stage during detail design.

In terms of successfully implementing the proposed storm water management plan, the following criteria must be met:

- It is imperative that the contaminated storm water trenches, boundary berms and starter walls be constructed on the edges of the next 2-year area to be lined prior to any stripping of vegetation for management of runoff during the construction period.
- All infrastructure specified for the 0 to 4 year storm water be constructed as soon as possible.
- PCDs must have water abstracted from them continuously as per pumping recommendations, and should be kept as empty as possible in order to ensure capacity for extreme events and minimise risk of spill.



Silke Louw  
PrEng



Charl Cilliers  
Project Manager

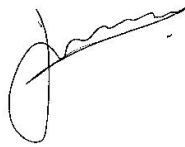

Jonathan Shamrock  
Project Director  
for Jones & Wagener

30 November 2017

*Document source: D:\Alljobs\G145\_Medupi\REV1\G145-00\_REP-01\_r1\_slccjfs\_ConceptDesignReport.docx*

*Document template: repGen\_17r5*

**ESKOM HOLDINGS SOC LIMITED**

MEDUPI POWER STATION  
NORTHERN ASH & GYPSUM DISPOSAL FACILITY  
CONCEPT DESIGN REPORT

Report: JW158/17/G145 – Rev 1

## **APPENDIX A**

# **LABORATORY TEST RESULTS**

**Client** : JONES & WAGENER (PTY) LTD  
**Address** : P O BOX 1434  
 : RIVONIA  
 : 2128

**Client Reference** :  
**Order No.** : PR17-06048

**Attention** :  
**Facsimile** : 011 519 0201  
**E-mail** : margaret@jaws.co.za; harmse@jaws.co.za; b

**Date Received** : 18/05/2017  
**Date Tested** : 18/05/2017 - 03/07/2017  
**Date Reported** : 03/07/2017

**Project** : Medupi Borrow Pit  
**Project No.** : 2017-B-891

**Report Status** : Final  
**Page** : 1 of 21

Herewith please find the test report(s) pertaining to the above project. All tests were conducted in accordance with prescribed test method(s). Information herein consists of the following:

Test(s) conducted / Item(s) measured	Qty.	Test Method(s)	Authorized By**	Page(s)
MDD & OMC	7.000	TMH1 A7	S Pullen/J Marques	12-18
Relative density of soil (SG)	10.000	TMH1 A12T	J Marques	6-11, 21
Moisture Content	10.000	SANS 3001	J Marques/S Pullen	6-11, 21
Atterberg Limits < 0.425mm	11.000	TMH1 A2, A3, A4	J Marques/S Pullen	6-11, 19-20
Sieve Analysis 0.075mm (Mass Grading)	11.000	TMH1 A1	J Marques/S Pullen	6-11, 19-20
Moisture content + dry density - Undisturbed Sample *	2.000	AASHTO 233	J Marques	21
C.B.R.	3.000	THM1 A8	S Pullen/J Marques	19-20
Hydrometer Analysis	11.000	ASTM D422	J Marques/S Pullen	6-11
Falling Head Permeability	9.000	BS-1377part5	C. Petersen	1 File: 1 Page

Any test results contained in this report and marked with \* in the table above are "not SANAS accredited" and are not included in the schedule of accreditation for this laboratory.

Any information contained in this test report pertain only to the areas and/or samples tested. Documents may only be reproduced or published in their full context.

While every care is taken to ensure that all tests are carried out in accordance with recognised standards, neither Civilab (Proprietary) Limited nor its employees shall be liable in any way whatsoever for any error made in the execution or reporting of tests or any erroneous conclusions drawn therefrom or for any consequences thereof.

All interpretations, Interpolations, Opinions and/or Classifications contained in this report falls outside our scope of accreditation.

The following parameters, where applicable, were excluded from the classification procedure: Chemical modifications, Additional fines, Fractured Faces, Soluble Salts, pH, Conductivity, Coarse Sand Ratio, Durability (COLTO: G4-G9).

The following parameters, where applicable, were assumed: Rock types were assumed to be of an Arenaceous nature with Siliceous cementing material.

Unless otherwise requested or stated, all samples will be discarded after a period of 3 months.

Deviations in Test Methods:

**APPROVED**

*By Joao Marques at 3:50 pm, Jul 03, 2017*

\*\*All results are authorized electronically by approved managers and/or technical signatories.





Client : JONES & WAGENER (PTY) LTD  
 Project : Medupi Borrow Pit  
 Project No : 2017-B-891

Date Received : 18/05/2017  
 Date Reported : 03/07/2017  
 Page No. : 4 of 21

## SAMPLING PLAN and METHODS

Lab. No.	Field No.	Sample Type/ Delivery	Client Ref. No.	Position	Description	Additional Information	Sampling			Remarks, Deviations etc.	Image
	Depth (m)						Method	Date	Time		
19	BTP23/01				Hillwash						
	0.30-1.00										
20	BTP 23/02				Hillwash						
	0.40-0.50										
22	CA1				Material Passing 4.75mm sieve						
23	BTP04/1				Hillwash						
	0.30-0.80										
24	BTP 06/2				Hillwash						
	0.40-1.70										





Client : JONES & WAGENER (PTY) LTD  
 Project : Medupi Borrow Pit  
 Project No : 2017-B-891

Date Received: 18/05/2017  
 Date Reported: 03/07/2017  
 Page No. : 6 of 21

### FOUNDATION INDICATOR

Laboratory Number	2	4
Field Number	BTP02/1	BTP04/1
Client Reference		
Depth (m)	0.60-1.10	0.30-0.80
Position		
Coordinates X		
Coordinates Y		
Description	Alluvium	Hillwash
Additional Information		
Calcrete / Crushed Stabilizing Agent		

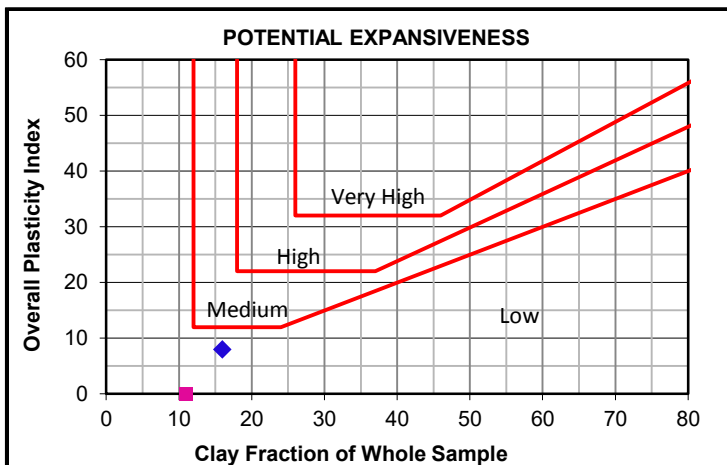

Moisture Content & Relative Density		
Moisture Content (%)	17.3	6.6
Relative Density (S.G.)	2.666	2.67

Sieve Analysis (Wet Prep) TMH1 A1			
Percentage Passing	100 mm	100	100
	75 mm	100	100
	63 mm	100	100
	53 mm	100	100
	37.5 mm	100	100
	26.5 mm	100	100
	19 mm	100	100
	13.2 mm	100	100
	4.75 mm	100	100
	2 mm	98	99
	0.85 mm	86	89
	0.425 mm	69	68
	0.250 mm	58	54
	0.150 mm	49	42
0.075 mm	38	26	
Grading Modulus	1	1.1	

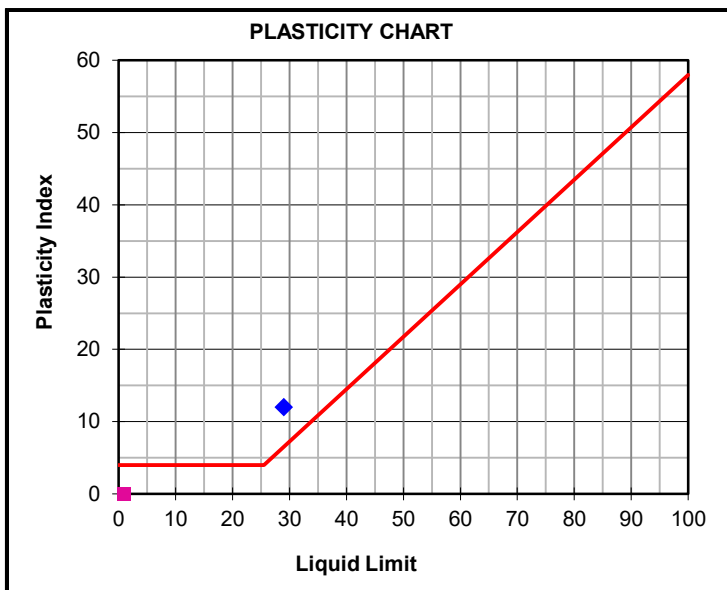

Hydrometer Analysis ASTM D422			
Percentage Passing	0.060 mm	30	23
	0.040 mm	21	19
	0.020 mm	19	16
	0.006 mm	17	13
	0.002 mm	16	11
Gravel	%	2	1
Sand	%	68	76
Silt	%	14	12
Clay	%	16	11

Laboratory Number	2	4
Atterberg Limits TMH1 A2, A3, A4		
Liquid Limit (%)	29	
Plasticity Index (%)	12	NP
Linear Shrinkage (%)	5.0	
Overall PI (%)	8	
Classifications		
HRB	A-6(1)	A-2-4(0)
Unified	SC	SM
Weston Swell @ 1 kPa	0.1	

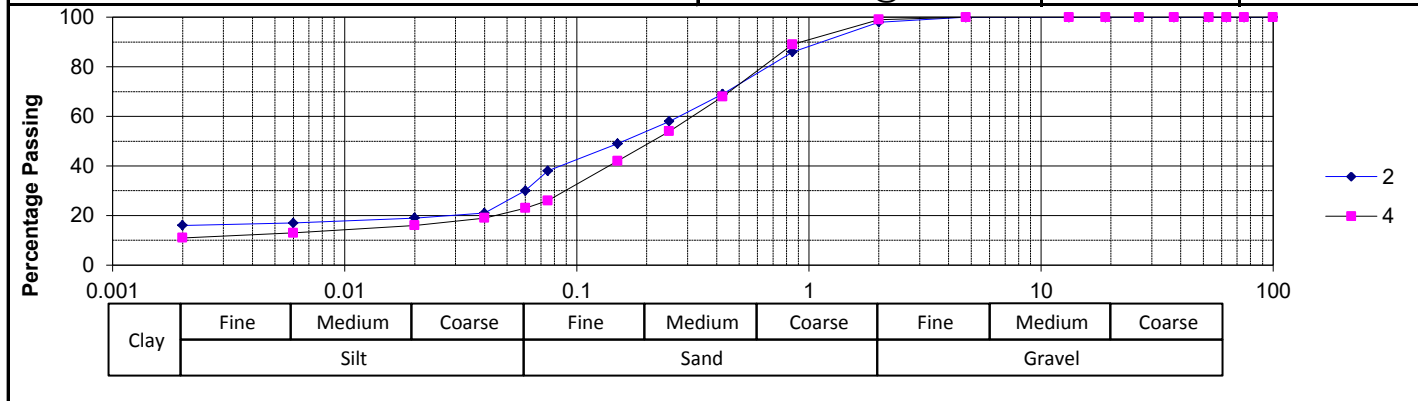

Client : JONES & WAGENER (PTY) LTD  
 Project : Medupi Borrow Pit  
 Project No : 2017-B-891

Date Received: 18/05/2017  
 Date Reported: 03/07/2017  
 Page No. : 7 of 21

### FOUNDATION INDICATOR

Laboratory Number	10 <span style="color:blue">◆</span>	11 <span style="color:magenta">■</span>
Field Number	BTP 06/2	BTP 08/1
Client Reference		
Depth (m)	0.40-1.70	0.40-1.00
Position		
Coordinates	X	
	Y	
Description	Hillwash	Hillwash
Additional Information		
Calcrete / Crushed Stabilizing Agent		

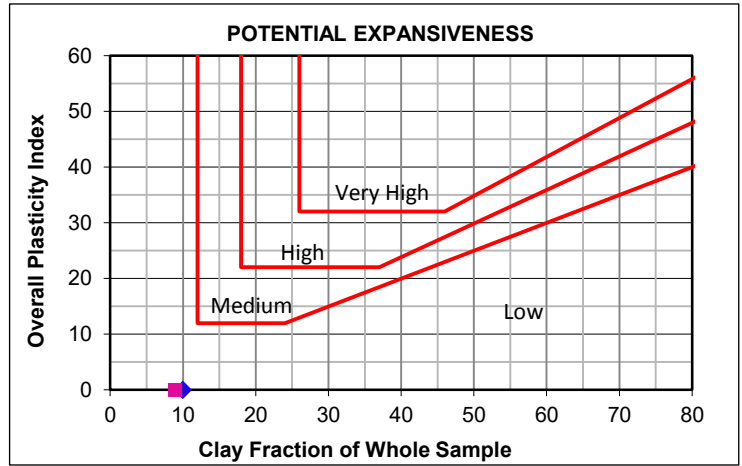

<b>Moisture Content &amp; Relative Density</b>		
Moisture Content (%)	4.6	4.5
Relative Density (S.G.)	2.677	2.75

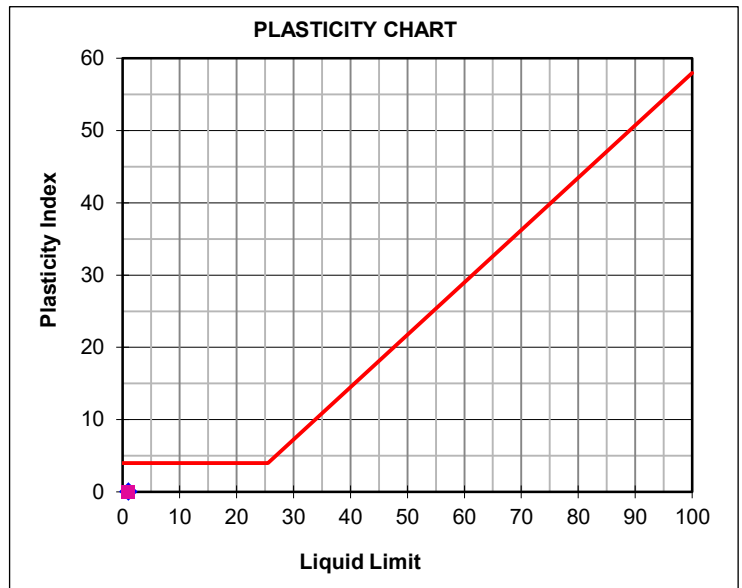

<b>Sieve Analysis (Wet Prep) TMH1 A1</b>			
Percentage Passing	100 mm	100	100
	75 mm	100	100
	63 mm	100	100
	53 mm	100	100
	37.5 mm	100	100
	26.5 mm	100	100
	19 mm	100	100
	13.2 mm	100	100
	4.75 mm	100	100
	2 mm	96	98
	0.85 mm	81	84
	0.425 mm	53	63
	0.250 mm	39	49
0.150 mm	31	37	
0.075 mm	21	21	
Grading Modulus	1.3	1.2	

Laboratory Number	10 <span style="color:blue">◆</span>	11 <span style="color:magenta">■</span>
<b>Atterberg Limits TMH1 A2, A3, A4</b>		
Liquid Limit	%	
Plasticity Index	%	NP
Linear Shrinkage	%	1.0
Overall PI	%	

<b>Hydrometer Analysis ASTM D422</b>			
Percentage Passing	0.060 mm	18	19
	0.040 mm	16	16
	0.020 mm	15	14
	0.006 mm	13	11
	0.002 mm	10	9
Gravel	%	4	2
Sand	%	78	79
Silt	%	8	10
Clay	%	10	9

<b>Classifications</b>		
HRB	A-2-4(0)	A-2-4(0)
Unified	SM	SM
Weston Swell @ 1 kPa		

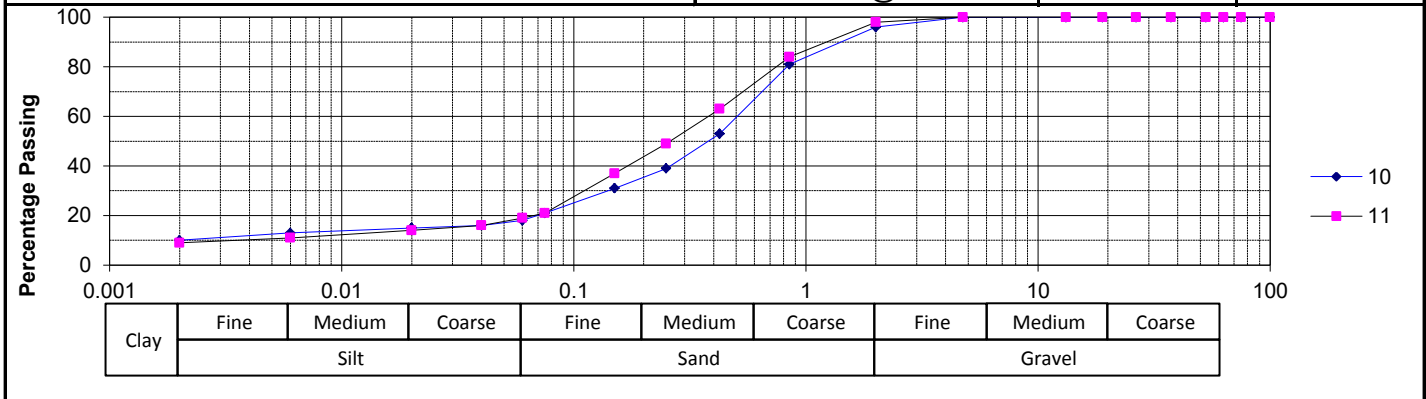

Client : JONES & WAGENER (PTY) LTD  
 Project : Medupi Borrow Pit  
 Project No : 2017-B-891

Date Received: 18/05/2017  
 Date Reported: 03/07/2017  
 Page No. : 8 of 21

### FOUNDATION INDICATOR

Laboratory Number	12 <span style="color:blue">◆</span>	14 <span style="color:magenta">■</span>
Field Number	BTP 09/1	BTP 14/1
Client Reference		
Depth (m)	1.80-2.30	1.00-1.50
Position		
Coordinates	X Y	
Description	Reworked Hillwash	Hillwash
Additional Information		
Calcrete / Crushed Stabilizing Agent		

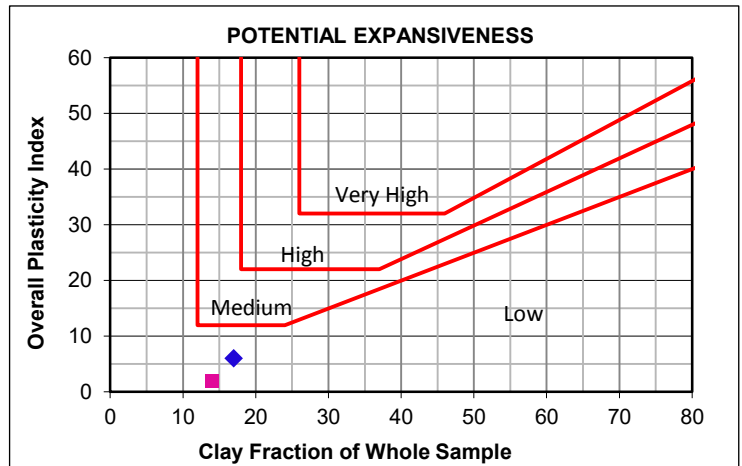

**Moisture Content & Relative Density**

Moisture Content (%)	11.2	7.4
Relative Density (S.G.)	2.692	2.748

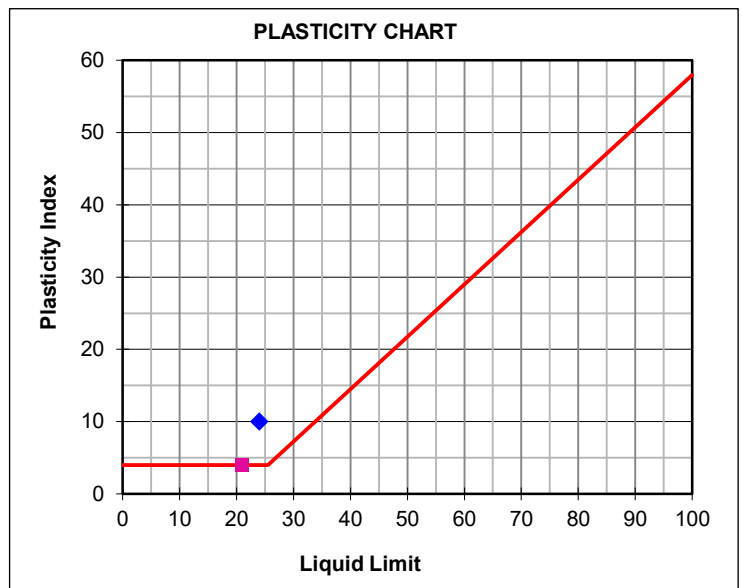

**Sieve Analysis (Wet Prep) TMH1 A1**

Percentage Passing	Sample 12	Sample 14
100 mm	100	100
75 mm	100	100
63 mm	100	100
53 mm	100	100
37.5 mm	100	100
26.5 mm	100	100
19 mm	100	100
13.2 mm	100	100
4.75 mm	100	100
2 mm	98	96
0.85 mm	81	82
0.425 mm	56	60
0.250 mm	45	47
0.150 mm	37	38
0.075 mm	29	26
Grading Modulus	1.2	1.2

**Hydrometer Analysis ASTM D422**

Percentage Passing	Sample 12	Sample 14
0.060 mm	27	23
0.040 mm	24	21
0.020 mm	22	20
0.006 mm	19	17
0.002 mm	17	14
Gravel	2	4
Sand	71	73
Silt	10	9
Clay	17	14

Laboratory Number	12 <span style="color:blue">◆</span>	14 <span style="color:magenta">■</span>
<b>Atterberg Limits TMH1 A2, A3, A4</b>		
Liquid Limit (%)	24	21
Plasticity Index (%)	10	4
Linear Shrinkage (%)	4.0	2.0
Overall PI (%)	6	2

**Classifications**

HRB	A-2-4(0)	A-2-4(0)
Unified	SC	SC-SM
Weston Swell @ 1 kPa	0.1	0.1

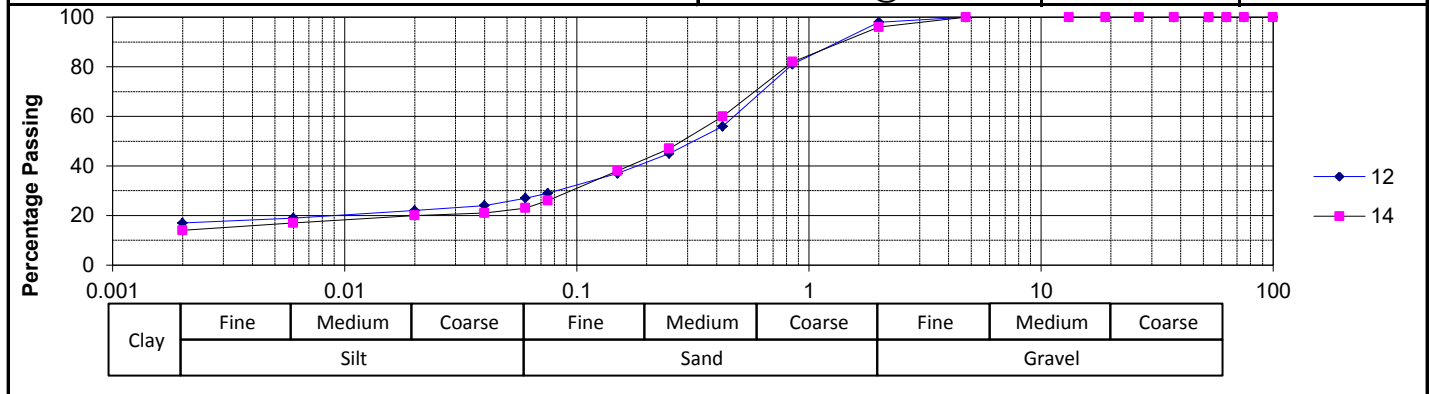

Client : JONES & WAGENER (PTY) LTD  
 Project : Medupi Borrow Pit  
 Project No : 2017-B-891

Date Received: 18/05/2017  
 Date Reported: 03/07/2017  
 Page No. : 9 of 21

### FOUNDATION INDICATOR

Laboratory Number	16	17
Field Number	BTP 14/2	BTP 21/01
Client Reference		
Depth (m)	Stockpile	0.50-1.00
Position		
Coordinates	X Y	
Description	Surface Dump	Hillwash
Additional Information		
Calcrete / Crushed Stabilizing Agent		

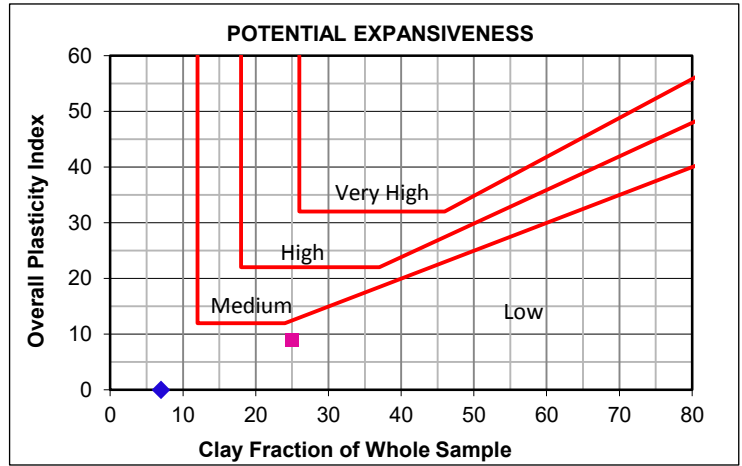

Moisture Content & Relative Density		
Moisture Content (%)	2.3	8.3
Relative Density (S.G.)	2.655	2.67

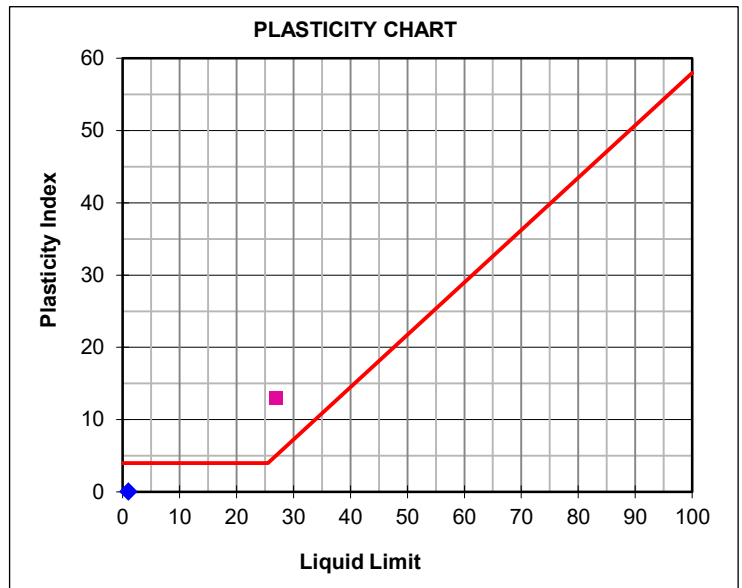

Sieve Analysis (Wet Prep) TMH1 A1			
Percentage Passing	100 mm	100	100
	75 mm	100	100
	63 mm	100	100
	53 mm	100	100
	37.5 mm	100	100
	26.5 mm	100	100
	19 mm	100	100
	13.2 mm	100	100
	4.75 mm	100	100
	2 mm	99	98
	0.85 mm	87	85
	0.425 mm	67	66
	0.250 mm	55	55
0.150 mm	36	46	
0.075 mm	21	35	
Grading Modulus	1.1	1	

Laboratory Number	16	17
Atterberg Limits TMH1 A2, A3, A4		
Liquid Limit	%	27
Plasticity Index	%	NP
Linear Shrinkage	%	5.0
Overall PI	%	9

Hydrometer Analysis ASTM D422			
Percentage Passing	0.060 mm	17	34
	0.040 mm	13	32
	0.020 mm	10	31
	0.006 mm	8	28
	0.002 mm	7	25
Gravel	%	1	2
Sand	%	82	64
Silt	%	10	9
Clay	%	7	25

Classifications		
HRB	A-2-4(0)	A-2-6(1)
Unified	SM	SC
Weston Swell @ 1 kPa		0.5

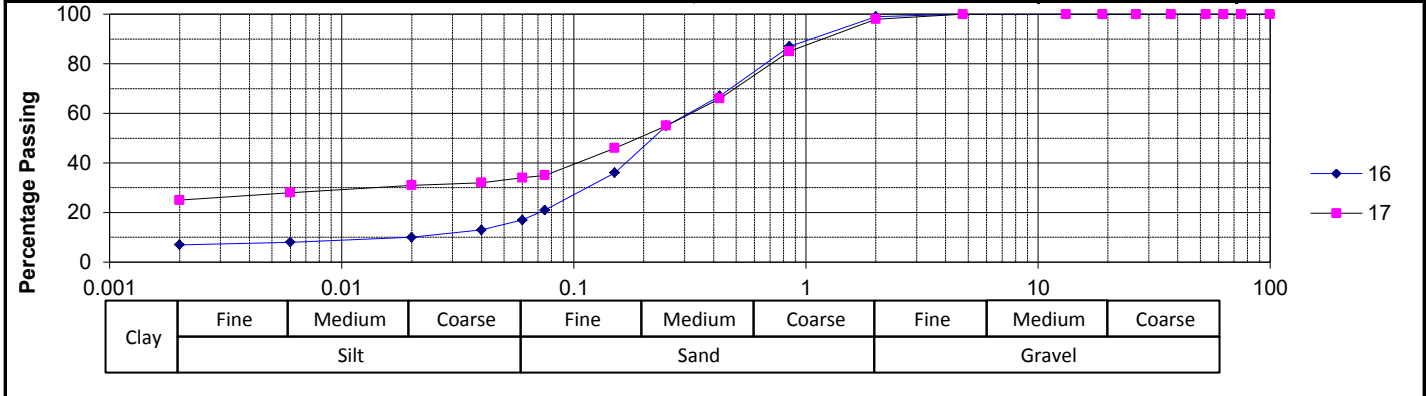

Client : JONES & WAGENER (PTY) LTD  
 Project : Medupi Borrow Pit  
 Project No : 2017-B-891

Date Received: 18/05/2017  
 Date Reported: 03/07/2017  
 Page No. : 10 of 21

### FOUNDATION INDICATOR

Laboratory Number	18 <span style="color:blue">◆</span>	19 <span style="color:magenta">■</span>
Field Number	BTP21/02	BTP23/01
Client Reference		
Depth (m)	1.00-1.30	0.30-1.00
Position		
Coordinates	X Y	
Description	Alluvium	Hillwash
Additional Information		
Calcrete / Crushed Stabilizing Agent		

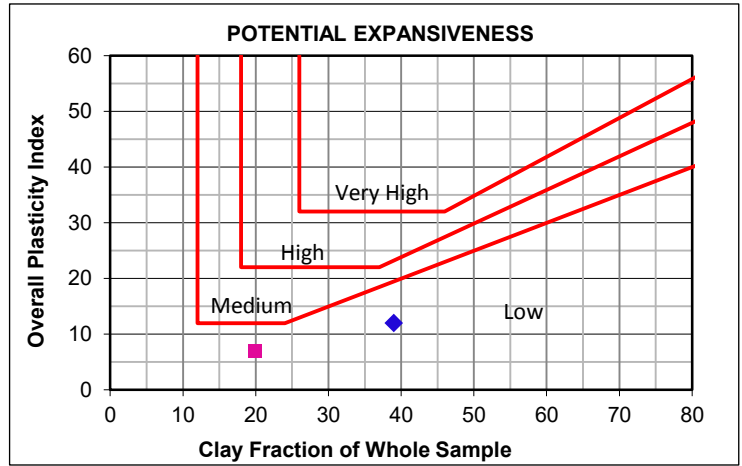

<b>Moisture Content &amp; Relative Density</b>		
Moisture Content (%)	14.6	13.8
Relative Density (S.G.)	2.738	2.68

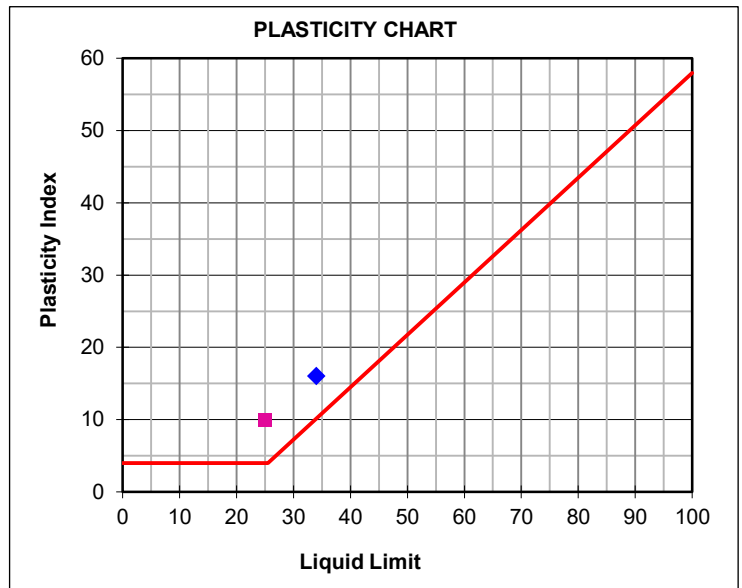

<b>Sieve Analysis (Wet Prep) TMH1 A1</b>			
Percentage Passing	100 mm	100	100
	75 mm	100	100
	63 mm	100	100
	53 mm	100	100
	37.5 mm	100	100
	26.5 mm	100	100
	19 mm	100	100
	13.2 mm	100	100
	4.75 mm	99	100
	2 mm	97	97
	0.85 mm	88	83
	0.425 mm	78	65
	0.250 mm	70	54
0.150 mm	62	46	
0.075 mm	51	36	
Grading Modulus	0.7	1	

Laboratory Number	18 <span style="color:blue">◆</span>	19 <span style="color:magenta">■</span>
<b>Atterberg Limits TMH1 A2, A3, A4</b>		
Liquid Limit (%)	34	25
Plasticity Index (%)	16	10
Linear Shrinkage (%)	6.0	4.0
Overall PI (%)	12	7

<b>Hydrometer Analysis ASTM D422</b>			
Percentage Passing	0.060 mm	49	34
	0.040 mm	45	30
	0.020 mm	43	27
	0.006 mm	42	23
	0.002 mm	39	20
Gravel (%)	3	3	
Sand (%)	48	63	
Silt (%)	10	14	
Clay (%)	39	20	

<b>Classifications</b>		
HRB	A-6(5)	A-4(0)
Unified	CL	SC
Weston Swell @ 1 kPa	0.7	0.1

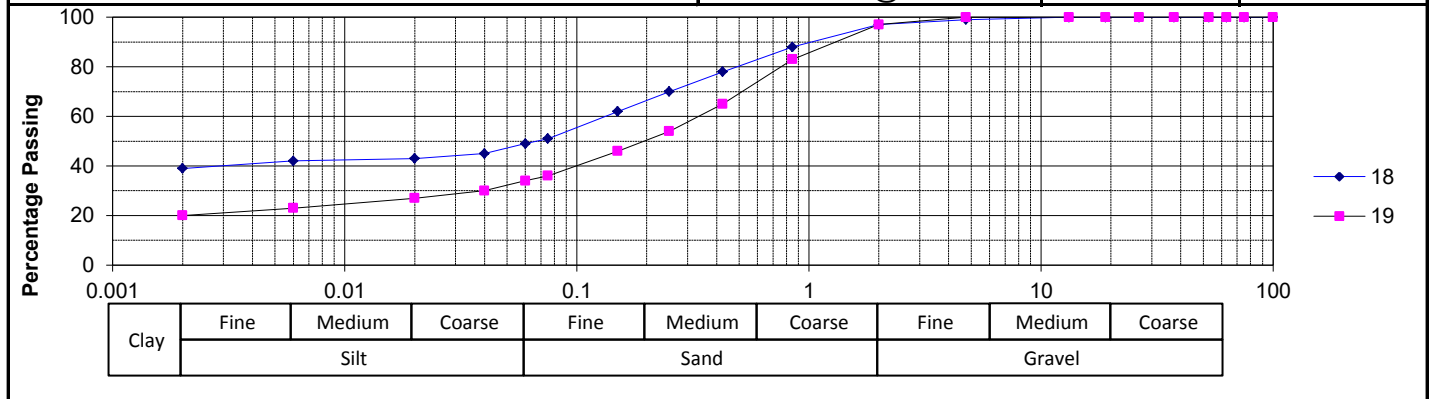

Client : JONES & WAGENER (PTY) LTD  
 Project : Medupi Borrow Pit  
 Project No : 2017-B-891

Date Received: 18/05/2017  
 Date Reported: 03/07/2017  
 Page No. : 11 of 21

## FOUNDATION INDICATOR

Laboratory Number	22	◆	■
Field Number	CA1		
Client Reference			
Depth (m)			
Position			
Coordinates	X		
	Y		
Description			
Additional Information	Material Passing 4.75mm sieve		
Calcrete / Crushed Stabilizing Agent			

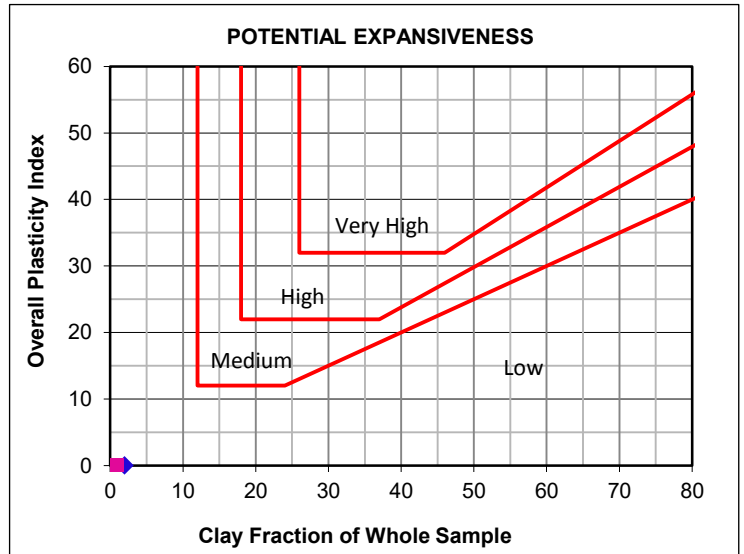

<b>Moisture Content &amp; Relative Density</b>		<b>TMH1 A7</b>
Moisture Content (%)		
Relative Density (S.G.)		

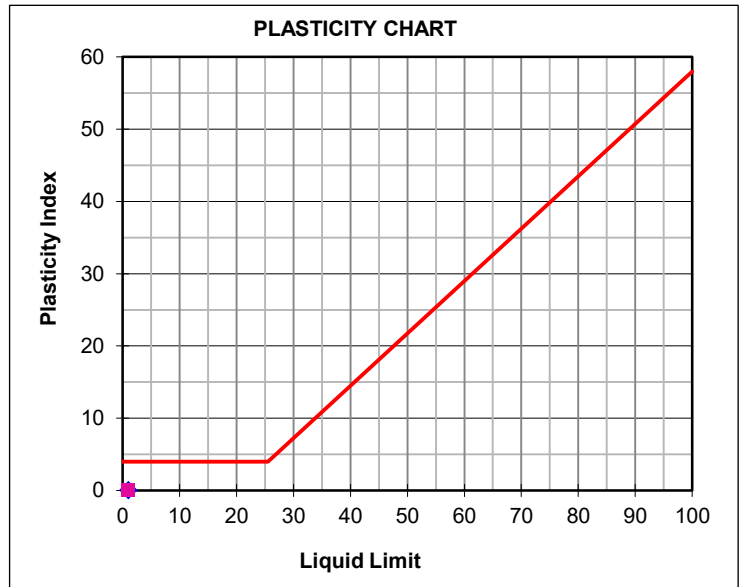

<b>Sieve Analysis (Wet Prep)</b>		<b>TMH1 A1</b>
Percentage Passing		
	100 mm	100
	75 mm	100
	63 mm	100
	53 mm	100
	37.5 mm	100
	26.5 mm	100
	19 mm	100
	13.2 mm	100
	4.75 mm	100
	2 mm	99
	0.85 mm	95
	0.425 mm	90
	0.250 mm	81
	0.150 mm	63
	0.075 mm	51
Grading Modulus		0.6

Laboratory Number	22	◆	■
<b>Atterberg Limits</b>		<b>TMH1 A2, A3, A4</b>	
Liquid Limit	%		
Plasticity Index	%	NP	
Linear Shrinkage	%		
Overall PI	%		

<b>Hydrometer Analysis</b>		<b>ASTM D422</b>
Percentage Passing		
	0.060 mm	37
	0.040 mm	21
	0.020 mm	11
	0.006 mm	5
	0.002 mm	2
Gravel	%	1
Sand	%	62
Silt	%	35
Clay	%	2

<b>Classifications</b>	
HRB	A-4(0)
Unified	ML
Weston Swell @ 1 kPa	

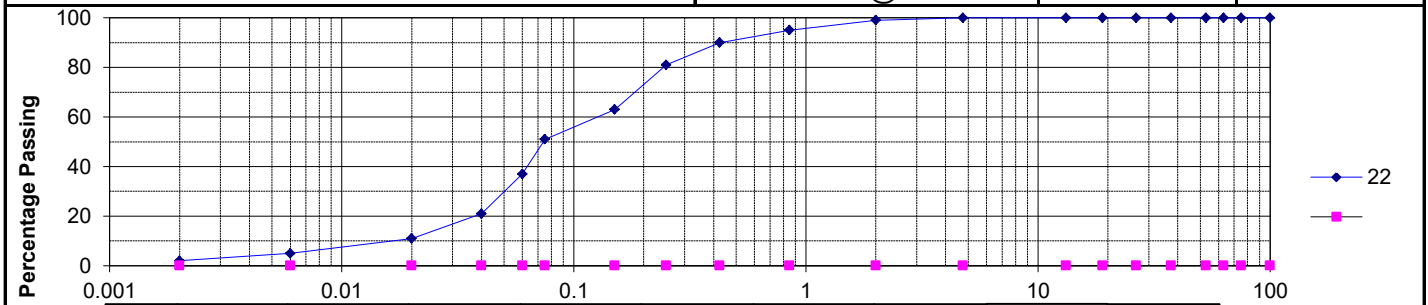

36 Fourth Street, Booyens Reserve, Johannesburg 2091

PO Box 82223, Southdale 2135

Tel: +27 (0)11 835 3117 • Fax: +27 (0)11 835 2503

E-mail: [jhb@civilab.co.za](mailto:jhb@civilab.co.za) • Website: [www.civilab.co.za](http://www.civilab.co.za)



T0062

# Civilab

**Civil Engineering Testing Laboratories**

Clay	Fine	Medium	Coarse	Fine	Medium	Coarse	Fine	Medium	Coarse
	Silt			Sand			Gravel		

Client : JONES & WAGENER (PTY) LTD  
 Project : Medupi Borrow Pit  
 Project No: 2017-B-891

Date Received: 18/05/2017  
 Date Reported: 03/07/2017  
 Page No. : 12 of 21

## MOISTURE DENSITY RELATIONSHIP

Laboratory Number	4	
Field Number	BTP04/1	
Client Reference		
Depth (m)	0.30-0.80	
Position		
Coordinates	X	
	Y	
Description	Hillwash	
Additional Information		
Calcrete / Crushed		
Stabilizing Agent		

### Maximum Dry Density & Optimum Moisture Content - TMH1 A7

Compactive Effort:	Modified AASHTO
--------------------	-----------------

Dry Density	kg/m <sup>3</sup>	2089	2127	2156	2121	2087	
Moisture Content	%	5	6	7	8	9	

Max. Dry Density	kg/m <sup>3</sup>	2156
Optimum Moisture	%	7

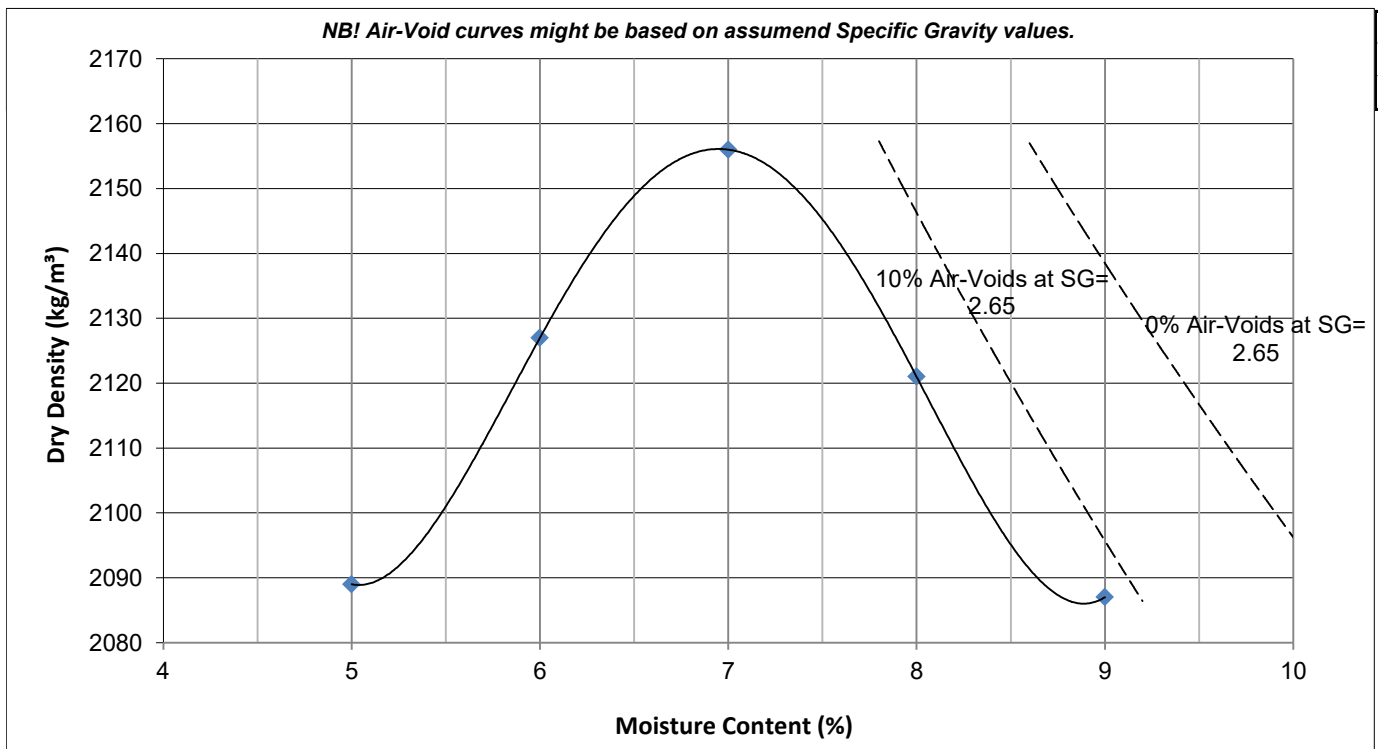



Client : JONES & WAGENER (PTY) LTD  
 Project : Medupi Borrow Pit  
 Project No: 2017-B-891

Date Received: 18/05/2017  
 Date Reported: 03/07/2017  
 Page No. : 13 of 21

## MOISTURE DENSITY RELATIONSHIP

Laboratory Number	14	
Field Number	BTP 14/1	
Client Reference		
Depth (m)	1.00-1.50	
Position		
Coordinates	X	
	Y	
Description	Hillwash	
Additional Information		
Calcrete / Crushed Stabilizing Agent		

### Maximum Dry Density & Optimum Moisture Content - TMH1 A7

Compactive Effort:	Modified AASHTO
--------------------	-----------------

Dry Density	kg/m <sup>3</sup>	2056	2095	2140	2111	2062	
Moisture Content	%	5.1	6.1	7.1	8.1	9.1	

Max. Dry Density	kg/m <sup>3</sup>	2141
Optimum Moisture	%	7.2

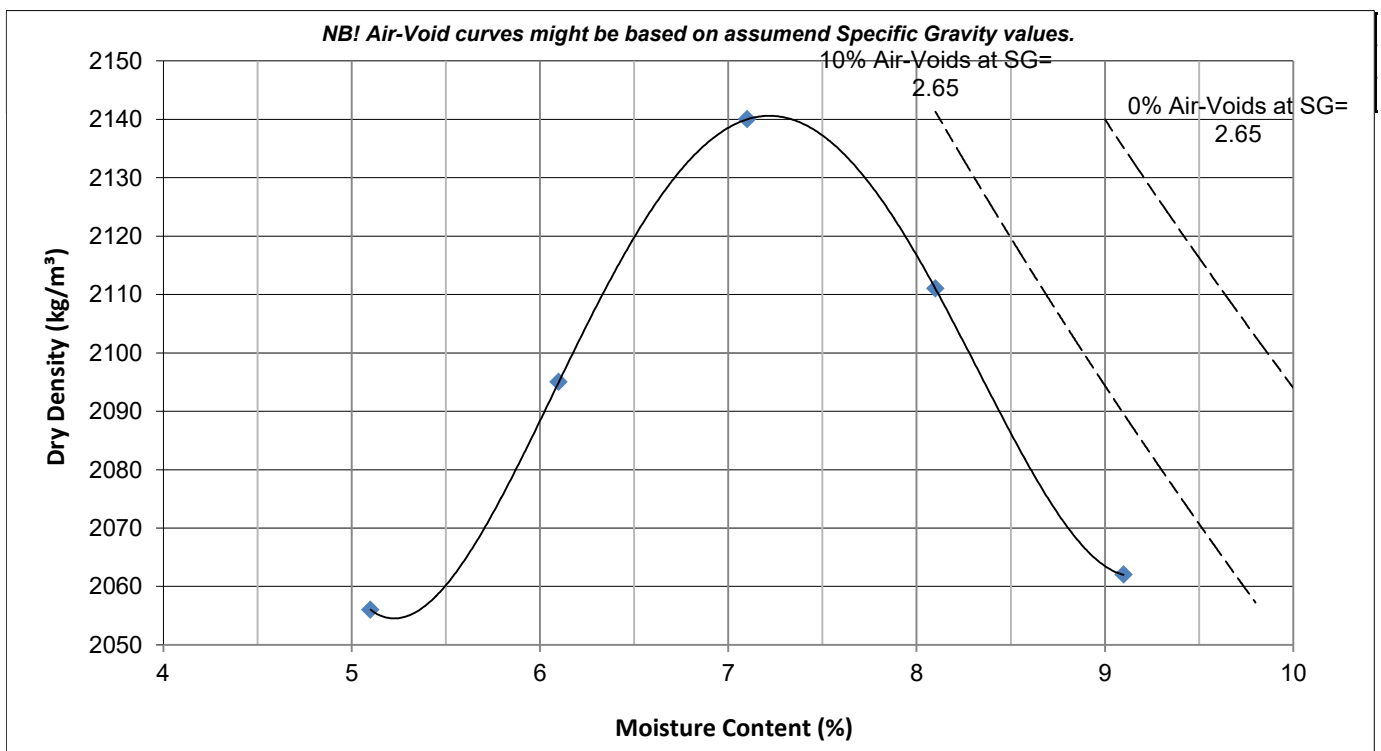

Client : JONES & WAGENER (PTY) LTD  
 Project : Medupi Borrow Pit  
 Project No: 2017-B-891

Date Received: 18/05/2017  
 Date Reported: 03/07/2017  
 Page No. : 14 of 21

## MOISTURE DENSITY RELATIONSHIP

Laboratory Number	22	
Field Number	CA1	
Client Reference		
Depth (m)		
Position		
Coordinates	X	
	Y	
Description		
Additional Information	Material Passing 4.75mm sieve	
Calcrete / Crushed		
Stabilizing Agent		

### Maximum Dry Density & Optimum Moisture Content - TMH1 A7

Compactive Effort:	Modified AASHTO
--------------------	-----------------

Dry Density	kg/m <sup>3</sup>	977	1007	1032	1002	982
Moisture Content	%	14.7	15.7	16.7	17.7	18.7

Max. Dry Density	kg/m <sup>3</sup>	1032
Optimum Moisture	%	16.6

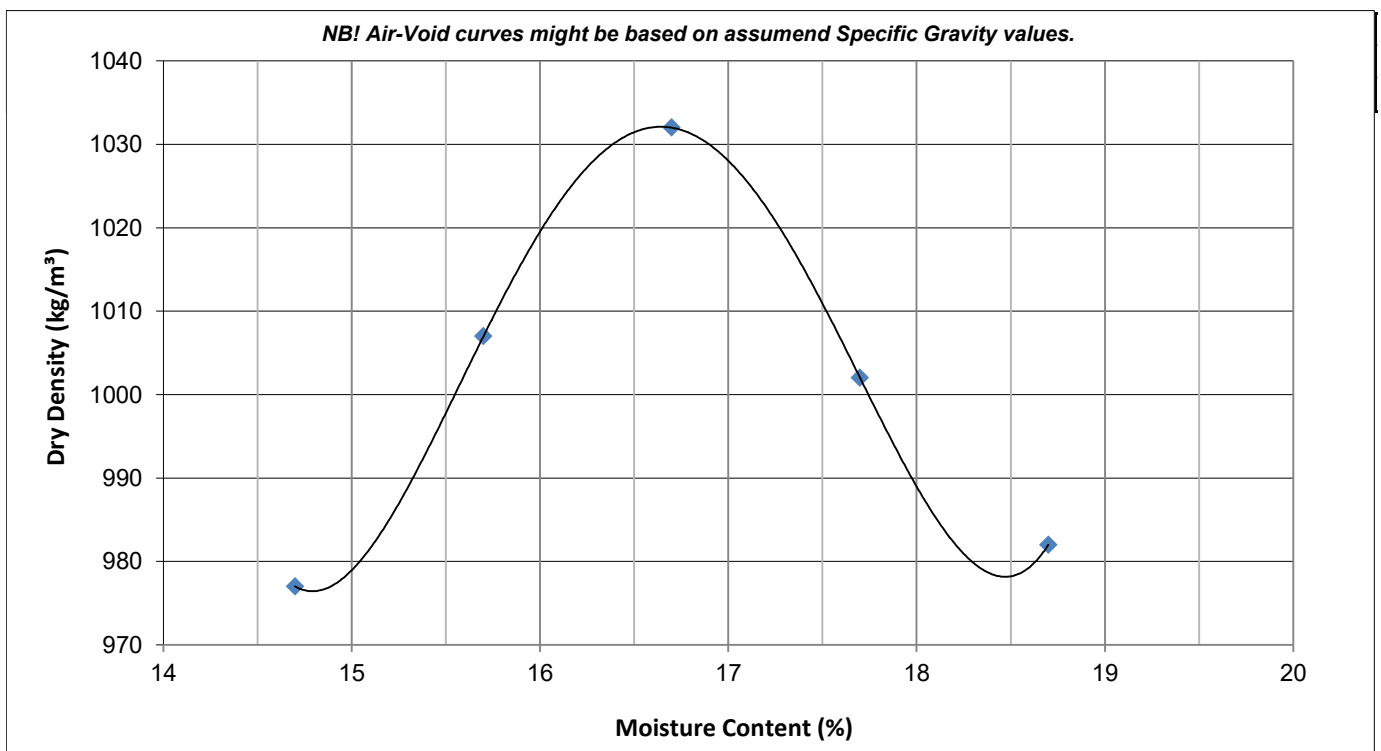

Client : JONES & WAGENER (PTY) LTD  
 Project : Medupi Borrow Pit  
 Project No: 2017-B-891

Date Received: 18/05/2017  
 Date Reported: 03/07/2017  
 Page No. : 15 of 21

## MOISTURE DENSITY RELATIONSHIP

Laboratory Number	23	
Field Number	BTP04/1	
Client Reference		
Depth (m)	0.30-0.80	
Position		
Coordinates	X	
	Y	
Description	Hillwash	
Additional Information		
Calcrete / Crushed Stabilizing Agent		

### Maximum Dry Density & Optimum Moisture Content - TMH1 A7

Compactive Effort:	Standard Proctor	
--------------------	------------------	--

Dry Density	kg/m <sup>3</sup>	1979	2035	2076	2044	1985	
Moisture Content	%	3.1	5.1	7.1	9.1	11.1	

Max. Dry Density	kg/m <sup>3</sup>	2076
Optimum Moisture	%	7.2

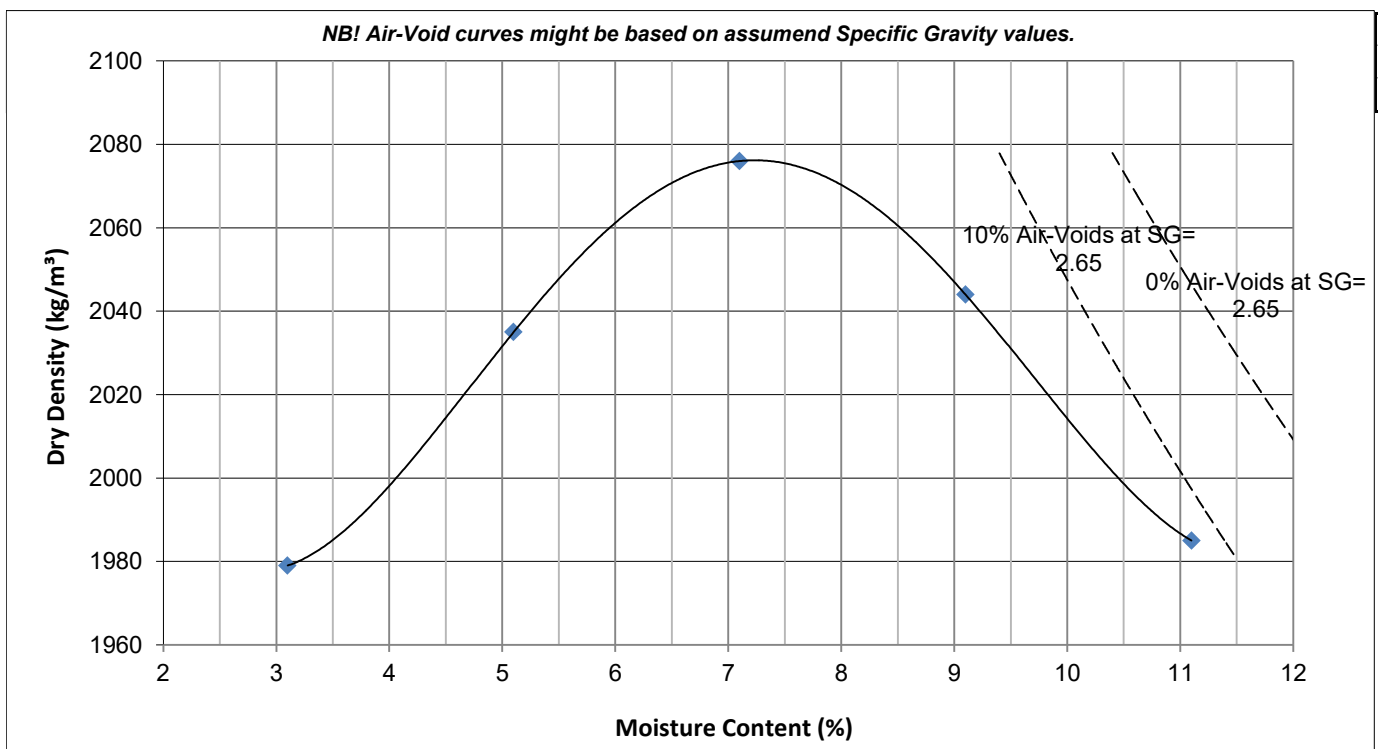

Client : JONES & WAGENER (PTY) LTD  
 Project : Medupi Borrow Pit  
 Project No: 2017-B-891

Date Received: 18/05/2017  
 Date Reported: 03/07/2017  
 Page No. : 16 of 21

## MOISTURE DENSITY RELATIONSHIP

Laboratory Number	24	
Field Number	BTP 06/2	
Client Reference		
Depth (m)	0.40-1.70	
Position		
Coordinates	X	
	Y	
Description	Hillwash	
Additional Information		
Calcrete / Crushed Stabilizing Agent		

### Maximum Dry Density & Optimum Moisture Content - TMH1 A7

Compactive Effort:	Standard Proctor
--------------------	------------------

Dry Density	kg/m <sup>3</sup>	2036	2079	2104	2086	2053	
Moisture Content	%	4.7	6.7	8.7	10.7	12.7	

Max. Dry Density	kg/m <sup>3</sup>	2104
Optimum Moisture	%	8.8

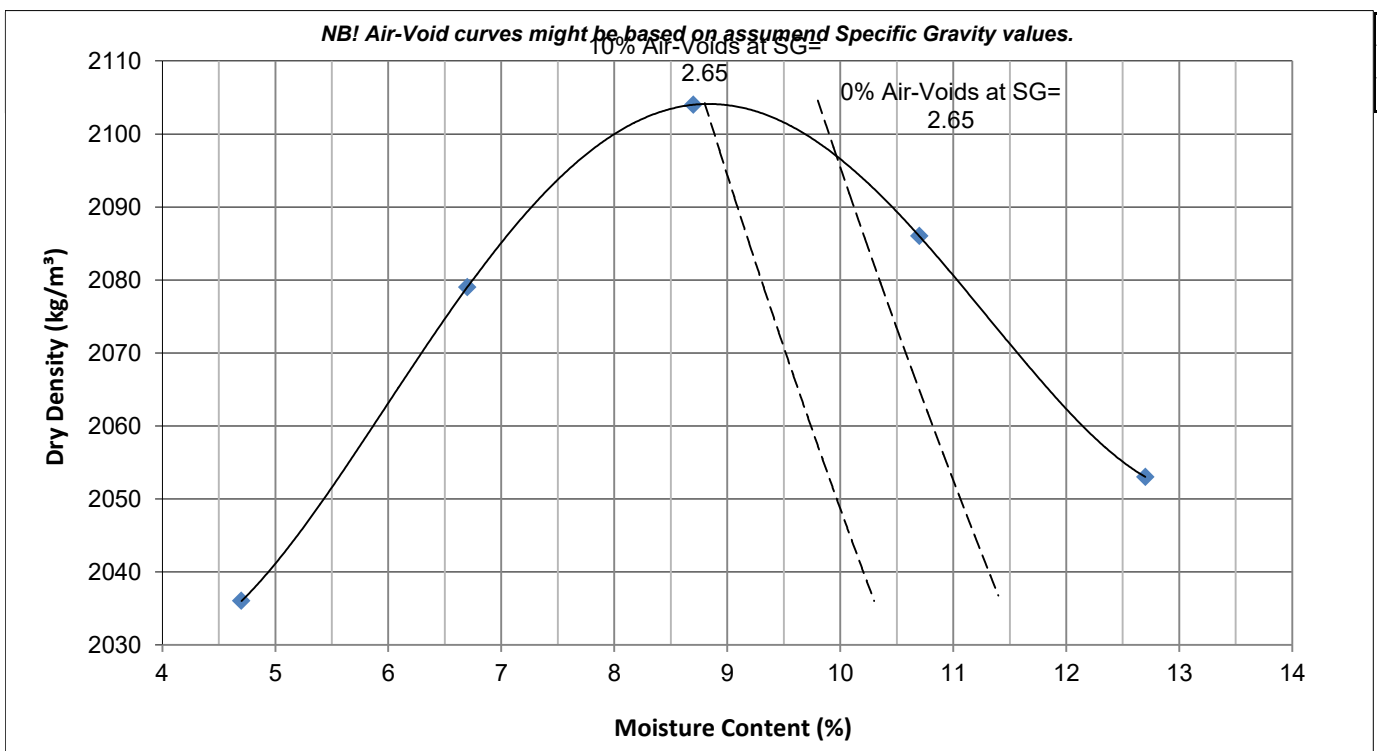

Client : JONES & WAGENER (PTY) LTD  
 Project : Medupi Borrow Pit  
 Project No: 2017-B-891

Date Received: 18/05/2017  
 Date Reported: 03/07/2017  
 Page No. : 17 of 21

## MOISTURE DENSITY RELATIONSHIP

Laboratory Number	25	
Field Number	BTP 14/1	
Client Reference		
Depth (m)	1.00-1.50	
Position		
Coordinates	X	
	Y	
Description	Hillwash	
Additional Information		
Calcrete / Crushed Stabilizing Agent		

### Maximum Dry Density & Optimum Moisture Content - TMH1 A7

Compactive Effort:	Standard Proctor
--------------------	------------------

Dry Density	kg/m <sup>3</sup>	2012	2047	2072	2062	2021
Moisture Content	%	3.7	5.7	7.7	9.7	11.7

Max. Dry Density	kg/m <sup>3</sup>	2073
Optimum Moisture	%	8.2

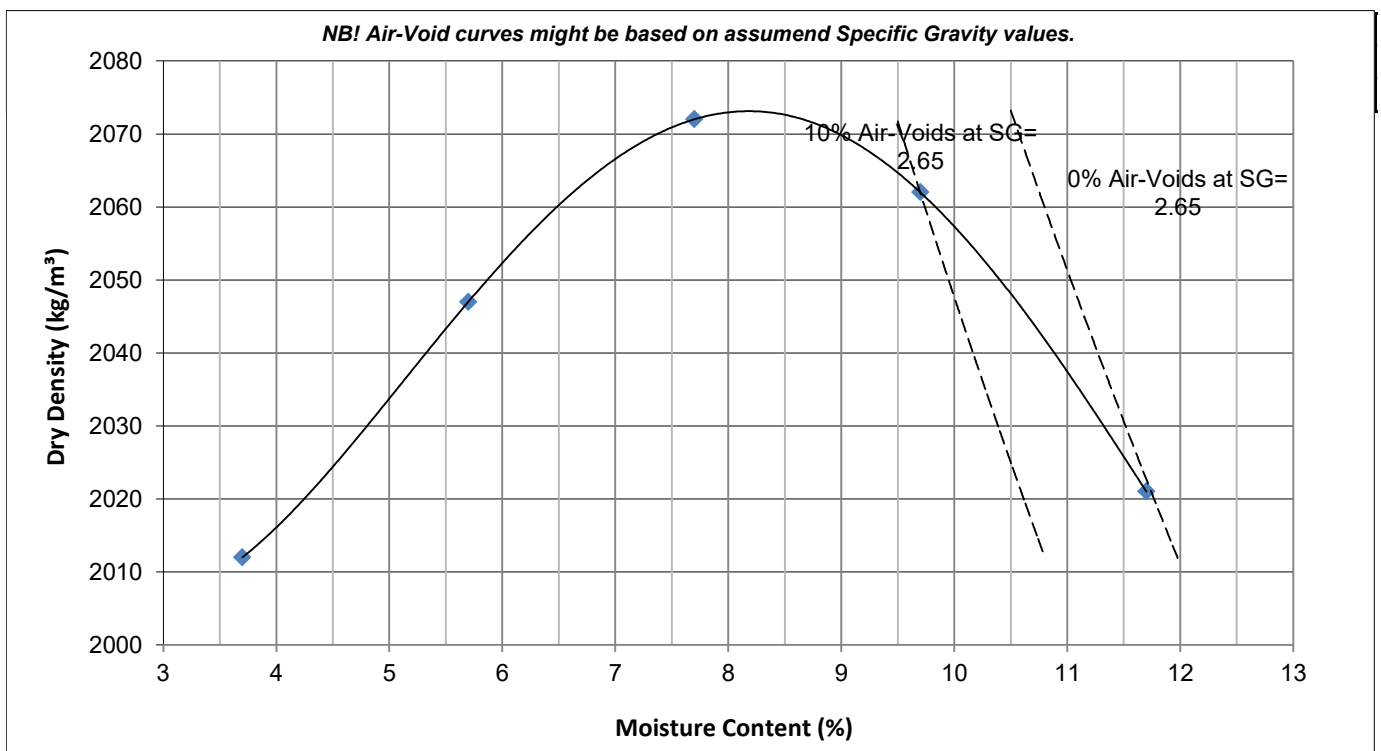

Client : JONES & WAGENER (PTY) LTD  
 Project : Medupi Borrow Pit  
 Project No: 2017-B-891

Date Received: 18/05/2017  
 Date Reported: 03/07/2017  
 Page No. : 18 of 21

## MOISTURE DENSITY RELATIONSHIP

Laboratory Number	27	
Field Number	Hillwash	
Client Reference		
Depth (m)		
Position		
Coordinates	X	
	Y	
Description	BTP04/1 :BTP06/1 : BTP08/1: BTP23/1	
Additional Information	Material Passing 4.75mm sieve	
Calcrete / Crushed		
Stabilizing Agent		

### Maximum Dry Density & Optimum Moisture Content - TMH1 A7

Compactive Effort:	Modified AASHTO
--------------------	-----------------

Dry Density	kg/m <sup>3</sup>	2069	2114	2165	2126	2065	
Moisture Content	%	5.1	6.1	7.1	8.1	9.1	

Max. Dry Density	kg/m <sup>3</sup>	2165
Optimum Moisture	%	7.2

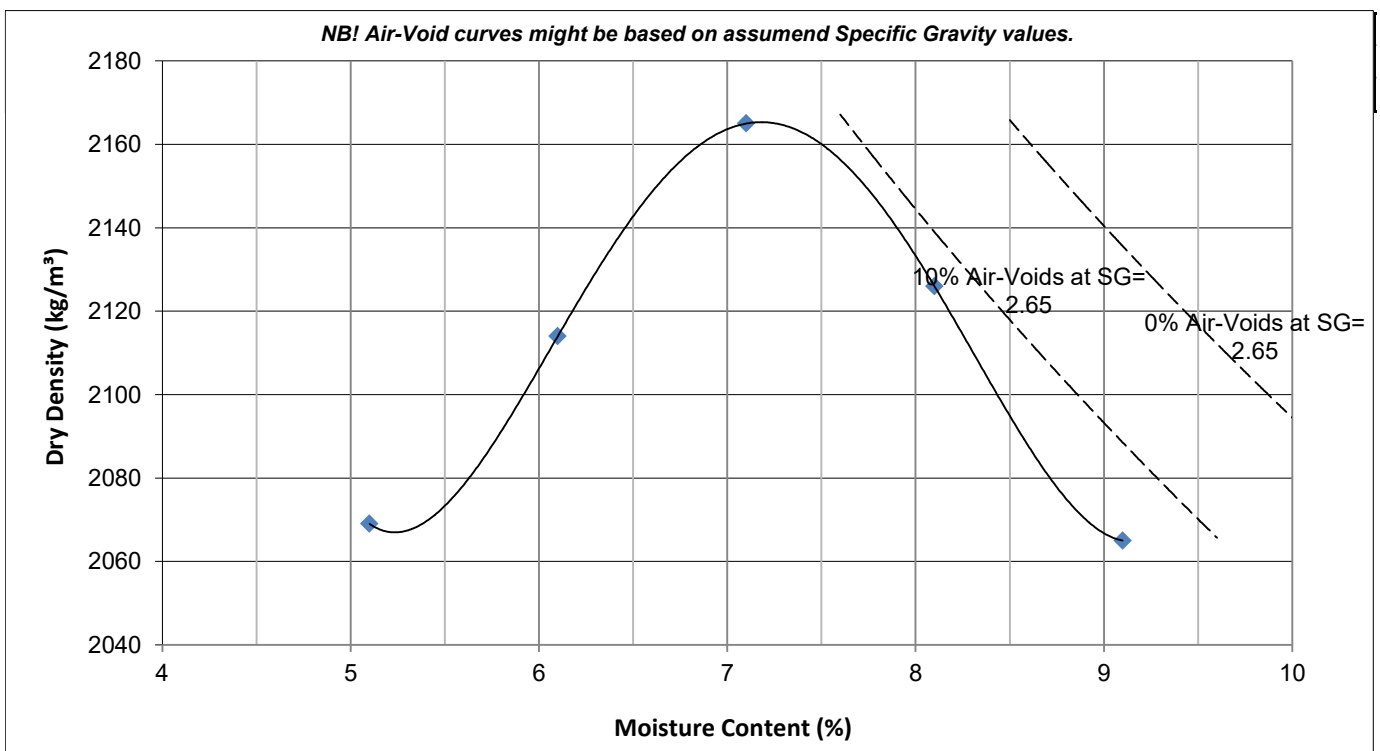

Client : JONES & WAGENER (PTY) LTD  
 Project : Medupi Borrow Pit  
 Project No. : 2017-B-891

Date Received : 18/05/2017  
 Date Reported : 03/07/2017  
 Page No. : 19 of 21

## CALIFORNIA BEARING RATIO (CBR) & ROAD INDICATOR REPORT

Laboratory No.	4	10
Field Number	BTP04/1	BTP 06/2
Client Reference		
Depth (m)	0.30-0.80	0.40-1.70
Position		
Coordinates	X	
	Y	
Description	Hillwash	Hillwash
Additional information		
Calcrete/Crushed		
Stabilizing Agent		

Laboratory No.	4	10
Maximum Dry Density & Optimum Moisture Content		
MDD	kg/m <sup>3</sup>	2156
OMC	%	7
		TMH1 A7
		2161
		6.7

California Bearing Ratio			TMH1 A8			
Compaction Data						
Moisture	%	7			6.7	
Dry Density	kg/m <sup>3</sup>	2180	2053	1962	2182	2075
Compaction	%	101.1	95.2	91.0	101.0	96.0
Penetration Data						
CBR at	2.54 mm	25	22	14	17	14
	5.08 mm	35	37	14	18	17
	7.62 mm	43	46	15	19	16
Swell	%	0.0	0.0	0.1	0.1	0.1
Final Moisture (%)		7.7	10.5	12.5	8.1	8.7

Sieve Analysis (Wet preparation)		TMH1 A1	
Percentage Passing	100 mm	100	100
	75 mm	100	100
	63 mm	100	100
	53 mm	100	100
	37.5 mm	100	100
	26.5 mm	100	100
	19 mm	100	100
	13.2 mm	100	100
	4.75 mm	100	100
	2 mm	99	96
	0.85 mm	89	81
	0.425 mm	68	53
	0.250 mm	54	39
0.150 mm	42	31	
0.075 mm	26	21	
Grading Modulus	1.1	1.3	

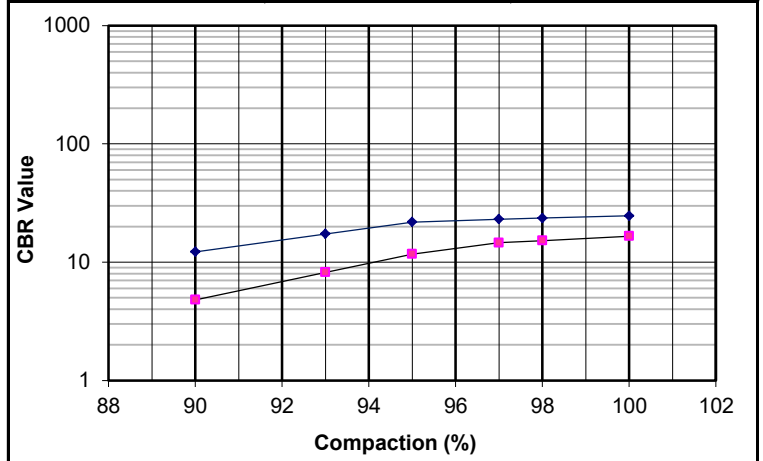

Interpolated CBR Data				
CBR	@ 100%	Mod. AASHTO	24.6	16.6
	@ 98%		23.6	15.2
	@ 97%		23.1	14.6
	@ 95%		21.8	11.7
	@ 93%		17.3	8.2
	@ 90%		12.2	4.8
	@		23.8	15.6

Soil Mortar Analysis		
Coarse Sand	31	45
Coarse Fine Sand	15	15
Medium Fine Sand	12	8
Fine Fine Sand	17	11
Silt and Clay	26	21

Classifications		
HRB	A-2-4(0)	A-2-4(0)
COLTO	G7	G9
TRH14	G7	G10

Atterberg Limits		
Liquid Limit (%)		
Plasticity Index (%)	NP	NP
Linear Shrinkage (%)		

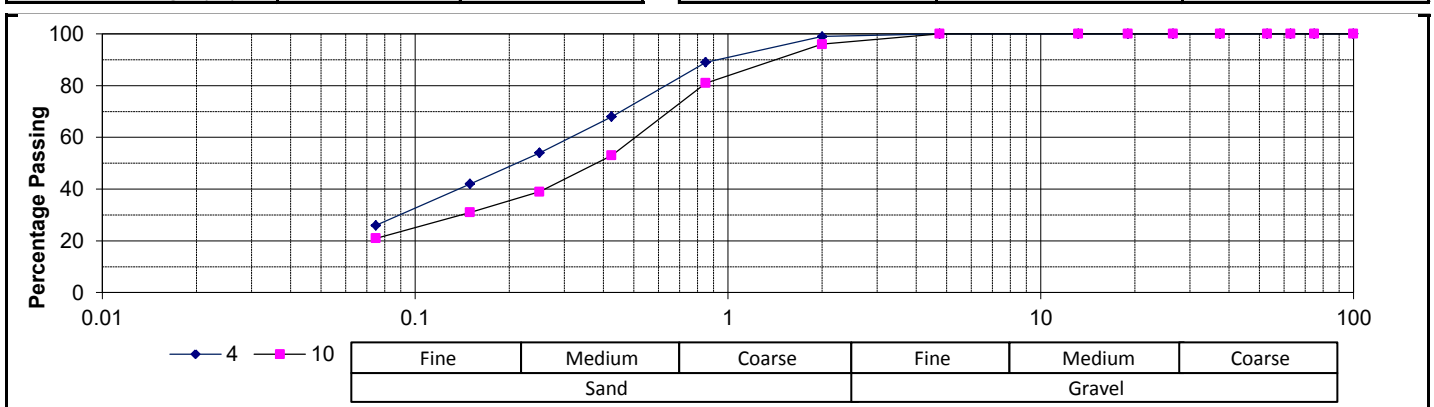

Client : JONES & WAGENER (PTY) LTD  
 Project : Medupi Borrow Pit  
 Project No. : 2017-B-891

Date Received : 18/05/2017  
 Date Reported : 03/07/2017  
 Page No. : 20 of 21

## CALIFORNIA BEARING RATIO (CBR) & ROAD INDICATOR REPORT

Laboratory No.	14	
Field Number	BTP 14/1	
Client Reference		
Depth (m)	1.00-1.50	
Position		
Coordinates	X	
	Y	
Description	Hillwash	
Additional information		
Calcrete/Crushed Stabilizing Agent		

Laboratory No.	14	
<b>Maximum Dry Density &amp; Optimum Moisture Content</b>		<b>TMH1 A7</b>
MDD	kg/m <sup>3</sup>	2141
OMC	%	7.2

<b>California Bearing Ratio</b>		<b>TMH1 A8</b>		
<b>Compaction Data</b>				
Moisture	%	7.1		
Dry Density	kg/m <sup>3</sup>	2150	2035	1930
Compaction	%	100.4	95.0	90.1
<b>Penetration Data</b>				
CBR at	2.54 mm	45	17	3
	5.08 mm	44	13	2
	7.62 mm	42	11	2
Swell	%	0.2	0.3	0.3
Final Moisture (%)		8.9	10.5	12.9

<b>Sieve Analysis (Wet preparation)</b>		<b>TMH1 A1</b>
Percentage Passing	100 mm	100
	75 mm	100
	63 mm	100
	53 mm	100
	37.5 mm	100
	26.5 mm	100
	19 mm	100
	13.2 mm	100
	4.75 mm	100
	2 mm	96
	0.85 mm	82
	0.425 mm	60
	0.250 mm	47
0.150 mm	38	
0.075 mm	26	
Grading Modulus		1.2

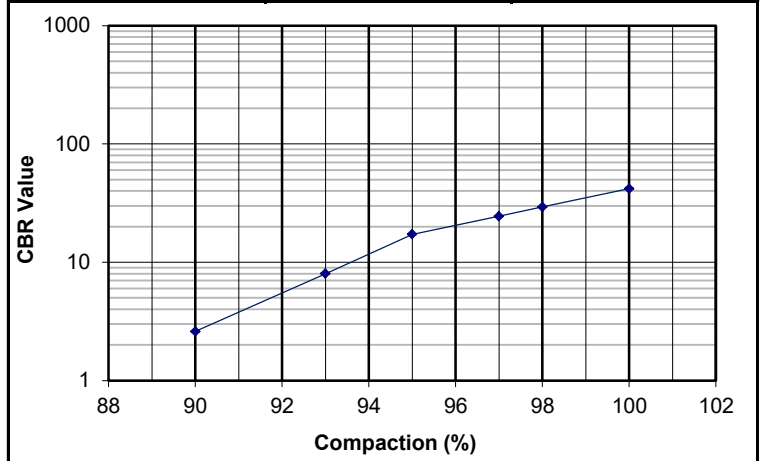

<b>Interpolated CBR Data</b>	
CBR @ 100%	41.8
CBR @ 98%	29.3
CBR @ 97%	24.5
CBR @ 95%	17.2
CBR @ 93%	8
CBR @ 90%	2.6
CBR @	27.9
Mod. AASHTO	

<b>Soil Mortar Analysis</b>	
Coarse Sand	38
Coarse Fine Sand	14
Medium Fine Sand	9
Fine Fine Sand	13
Silt and Clay	27

<b>Classifications</b>	
HRB	A-4(0)
COLTO	G9
TRH14	None

<b>Atterberg Limits</b>		<b>TMH1 A2, A3, A4</b>
Liquid Limit (%)	21	
Plasticity Index (%)	4	
Linear Shrinkage (%)	2.0	

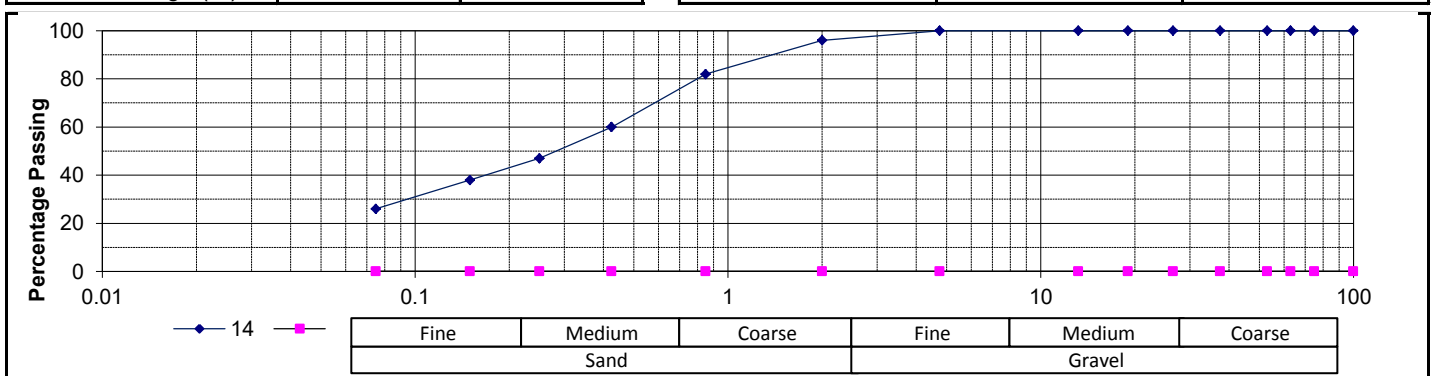



Client : JONES &amp; WAGENER (PTY) LTD

Date Received : 18/05/2017

Project : Medupi Borrow Pit

Date Reported : 03/07/2017

Project No: 2017-B-891

Page No. : 21 of 21

## MOISTURE CONTENT, BULK-, DRY- & RELATIVE DENSITY

Lab No	Field No	Depth (m)	Coordinates	Description / Additional Information	Moisture Content	Density		Relative Density (S.G.)		Void Ratio	Degree of Saturation
						kg/m <sup>3</sup>		Estimated	Determined		
						Bulk	Dry				
2	BTP02/1	0.60-1.10	X: Y:	Alluvium	17.3			2.666			
4	BTP04/1	0.30-0.80	X: Y:	Hillwash	6.6			2.67			
8	BTP 06/1	1.00-1.10	X: Y:	Hillwash	2.3	1742	1703	2.65		0.5561	11
10	BTP 06/2	0.40-1.70	X: Y:	Hillwash	4.6			2.677			
11	BTP 08/1	0.40-1.00	X: Y:	Hillwash	4.5			2.75			
12	BTP 09/1	1.80-2.30	X: Y:	Reworked Hillwash	11.2			2.692			
14	BTP 14/1	1.00-1.50	X: Y:	Hillwash	7.4			2.748			
16	BTP 14/2	Stockpile	X: Y:	Surface Dump	2.3			2.655			
17	BTP 21/01	0.50-1.00	X: Y:	Hillwash	8.3			2.67			
18	BTP21/02	1.00-1.30	X: Y:	Alluvium	14.6			2.738			
19	BTP23/01	0.30-1.00	X: Y:	Hillwash	13.8			2.68			
20	BTP 23/02	0.40-0.50	X: Y:	Hillwash	6.1	1770	1668	2.65		0.5887	27
			X: Y:								
			X: Y:								

## Falling Head Permeability Test Results

Project:	MEDUPI BORROW PIT		
Project No:	2017-B-891	Date:	12/06/2017

Lab. Sample Reference	Field Sample Reference	Depth (m)	Moisture Contents		Dry density Kg/m <sup>3</sup>		Coefficient of Permeability (m/s)		
			Before Test (%)	After Test (%)	Initial	As tested	Range		Average
							Minimum	Maximum	
891-4	BTP 04/1	0.3 - 0.8	12.1	19.0	1957	1978	1.3E-07	1.6E-07	<b>1.4E-07</b>
891-4 : 4% Bentonite	BTP 04/1	0.3 - 0.8	8.8	11.0	2171	2207	5.2E-10	1.4E-09	<b>7.8E-10</b>
891-4 : 6% Bentonite	BTP 04/1	0.3 - 0.8	9.0	11.8	1969	1996	1.5E-10	4.9E-10	<b>3.4E-10</b>
891-10	BTP 06/2	0.4 - 1.7	10.3	10.3	2072	2136	9.4E-10	1.3E-09	<b>1.1E-09</b>
891-10 : 6% Bentonite	BTP 06/2	0.4 - 1.7	10.8	11.5	2057	2075	4.2E-11	5.2E-10	<b>1.6E-10</b>
891-14	BTP 14/1	1.0 - 1.5	11.0	11.6	1993	2054	2.3E-09	4.2E-09	<b>3.4E-09</b>
891-14 : 4% Bentonite	BTP 14/1	1.0 - 1.5	10.3	12.4	1959	1977	1.2E-10	5.0E-10	<b>2.8E-10</b>
891-22	CA 1	-	19.0	48.3	959	969	1.8E-06	2.1E-06	<b>1.9E-06</b>
891-27	HILLWASH	-	13.0	11.3	1988	2018	2.7E-07	3.4E-07	<b>2.9E-07</b>

Remarks: Samples remoulded to approximately 98% Proctor @ MC + 1-3%  
Saturated and tested under a load of 100kPa.  
Densities reported are under a load of 100kPa.

**ESKOM HOLDINGS SOC LIMITED**

MEDUPI POWER STATION  
NORTHERN ASH & GYPSUM DISPOSAL FACILITY  
CONCEPT DESIGN REPORT

Report: JW158/17/G145 – Rev 1

## **APPENDIX B**

### **J&W NOTE: LINER SERVICE LIFE**

 <b>Jones &amp; Wagener</b> Consulting Civil Engineers 59 Bevan Road PO Box 1434 Rivonia 2128 South Africa Tel: 00 27 (0)11 519 0200 Fax: 00 27 (0)11 519 0201 email: post@jaws.co.za			<b>NOTE</b>
DESCRIPTION	Service life of 1.5mm HDPE geomembrane that meets the GRI-GM 13 specification	JOB No.	B754/00
FILE NAME	001_LinerServiceLife_r2.docx	DATE	2 December , 2013

**Estimated service life of a 1.5mm HDPE geomembrane that meets the GRI-GM 13 specification**

The service life of a geomembrane as defined by Rowe (2005) is “the period of time or which an engineered component of a barrier system performs in accordance with the design”. Failure of the component is defined as the stage when specific properties of the component reduce to 50% of their original value or half-life. It is related to the durability of the component which in turn is related to the change of critical properties, such as tensile strength, over time.

The durability of a geomembrane is affected by external factors such as exterior chemical effects (e.g. leachate), mechanical loading, heat, moisture change & frost and internal factors such as material or chemical aging.

When geomembranes are effectively protected from external factors it is the internal factors (i.e. chemical aging) that are of most concern in terms of failure.

There are three stages to chemical aging:

1. Depletion time of antioxidants;
2. Induction time to the onset of polymer degradation;
3. Degradation of the polymer to decrease some properties to an arbitrary level (say 50% of original value).

Rowe (2005) stated the following:

*It is not feasible to measure the length of these stages for actual field conditions because of the long time required to obtain useful results. Consequently, tests are conducted at elevated temperatures to accelerate ageing and the results are extrapolated to temperatures expected at the base of a landfill.*

Although this type of simulation provides answers to researchers in the short term, it requires extensive modelling and laboratory testing in order to provide an estimate on service life. Therefore in order to provide a service life estimate for the geomembrane on site, the values published in literature give the best available information to base the estimate on. These tests are carried out on specific lining systems and in specific conditions and care is required to ensure that the estimate includes a level of conservatism.

### **Phase 1: Depletion time of antioxidants**

Antioxidants are additives that are mixed in with the resin material when the geomembrane is manufactured. The antioxidants are chemical compounds that prevent the oxidation of the geomembrane for a certain length of time thereby increasing the durability and service life of the geomembrane.

The ability of the antioxidant package to resist oxidation is measured by the Oxidation Induction Time (OIT) test (ASTM D3895). GRI-GM13 calls for an OIT of 100min.

The latest simulated geomembrane aging tests to estimate the first stage of chemical aging were carried out by Sangam and Rowe (2002). The results of these tests are summarised by Rowe (2005) and are used in this note for the service life estimate. Their simulation is based on the following:

Liner Setup (from the bottom):

- Unsaturated sand subgrade;
- Geosynthetic Clay Liner;
- 1.5mm HDPE geomembrane liner;
  - Initial OIT of 135 minutes (average initial OIT at Medupi: Textured 160.3 min Smooth 154 min);
  - Crystallinity 49%
- Geotextile protection layer;
- Gravel saturated with leachate.

Process

- Samples are placed in baths and maintained at temperatures of 26, 55, 70 and 85°C;
- Test cells are periodically terminated and tested for a decrease in critical properties;
- Leachate is repeatedly replaced.

The simulation is conservative because:

- The simulation assumes that the geomembrane is consistently exposed to leachate;
- The leachate strength remains consistent as the leachate is repeatedly replaced;
- The simulation is run on a geomembrane with a lower value of initial OIT than the geomembrane on site which indicates that the service life estimates will also be lower than site conditions.

### **Phase 2 and 3: Induction time to the onset of polymer degradation and degradation of the polymer to decrease some properties to an arbitrary level (50%)**

At present there is very limited data for the other stages of aging (Rowe 2005). Some studies have been carried out on HDPE pipes and others on exhumed milk bottles from landfill. From the results of these studies Rowe (2005) has provided results of service life for these phases versus different temperatures.

The final result of the estimation of the average service life (all three phases) of the 1.5mm HDPE geomembrane (smooth or textured), as stated by Rowe (2005), is **160 years** for liner temperatures of 35°C. The average ambient temperature for Lephalale during December / January is 32°C and 22°C during June / July. The lower temperatures during the year, other than the December/January period, will prolong the service life of the geomembrane in excess of the estimate above.

### **Effect of temperature on geomembrane service life**

High temperatures have a negative effect on the service life of a geomembrane. This was illustrated by Rowe (2005) who stated that the average service life of 1.5mm HDPE geomembrane can reduce from **160 years to 15 years** if the temperature at the liner is increased from 35° to 60°C.

da Silva (2013) found that ash facilities do have the potential to generate heat through hydration of the ash. A model using the one dimensional heat transport equation was used to analyse the temperature at the lining system of an ash facility. Depending on the heat of hydration parameter used, the temperature at the liner varied from 30° to 100°C which had a dramatic effect of the estimation of the service life of the geomembrane reducing it to less than 15 years.

The following recommendations were made by the paper:

- More extensive studies and experimental testing is required on the chemistry of the ash to determine its heat generation potential, the duration of the hydration reaction, as well as the potential for the hydration reaction to run to completion in the ash deposit. The thermal properties of ash deposits such as the thermal conductivity and heat capacity need to be determined.
- Long term temperature monitoring at the base of ash deposition facilities as well as drilling into existing facilities to measure temperature gradients would be required to calibrate the existing modelling techniques and provide better estimates of input parameters.
- Further studies in order to determine the influence of higher HDPE resistance properties on the service life would be required to determine the impact of changing or increasing these properties.

As the potential for heat generation in ash fills is as yet not defined, the conservative estimate of 160 years based on 35°C should be used for the estimate of service life of a 1.5mm HDPE GRI GM13 geomembrane.

#### References:

da Silva, T. (2013). *Temperature considerations in geomembrane lined ash deposition facilities*. Landfill 2013

Rowe, R. K. (2005). *Long-term performance of contaminant barrier systems*. 45th Rankine Lecture. Geotechnique 55, No. 9, 631–678

Sangam, H. P. & Rowe, R. K. (2002). *Effects of exposure conditions on the depletion of antioxidants from high-density polyethylene (HDPE) geomembranes*. Can. Geotech. J. 39, No. 6, 1221–1230.

**ESKOM HOLDINGS SOC LIMITED**

MEDUPI POWER STATION  
NORTHERN ASH & GYPSUM DISPOSAL FACILITY  
CONCEPT DESIGN REPORT

Report: JW158/17/G145 – Rev 1

## **APPENDIX C**

### **GROWTH PLAN**



# Jones & Wagener

Engineering & Environmental Consultants

59 Bevan Road PO Box 1434 Rivonia 2128 South Africa  
 tel:0027 11 519 0200 www.jaws.co.za email:post@jaws.co.za

Client:  
Job Des.

Eskom  
 Conceptual Modelling for Medupi Power station  
 Northern Ash Dump Facility

Job No: G145/00  
 Sheet No: 1  
 Made by: SL  
 Date: 23/11/2017

<b>Ash</b>	Power generated	136,28 t/p/h/unit	800 MW	Starting date	01/08/2015		
	No. of units	6					
	Base load factor	81%					
	Ash tonnage dry	1 193 813 t/U/yr					
	Ash dry density	800 kg/m <sup>3</sup>					
	Ashmake (annual design)	8 953 596 m <sup>3</sup> /yr		Deposition rate (Gypsum Excl.)	746 133 m <sup>3</sup> /mth/6U	Deposition rate (Incl. Gypsum)	970 958,40
	Ashmake (annual design)	1 492 266 m <sup>3</sup> /yr/unit		% Volume split	100%		

<b>Gypsum</b>	<b>FGD Gypsum</b>	51,33 t/h/unit
	FGD Gypsum	7 391,5200 t/day/6Units
	Total FGD Gypsum mass	
	Density t/m <sup>3</sup>	1 t/m <sup>3</sup>
	FGD Gypsum Vol	7 392 m <sup>3</sup> /day/6Units
	FGD Gypsum Vol	2 697 904,80 m <sup>3</sup> /yr/6Units

Unit commissioning (Gypsum Excl.)	
1	01/08/2015 124 355,50
2	30/01/2016 248 711,00
3	31/07/2016 373 066,50
4	29/01/2017 497 422,00
5	31/07/2017 621 777,50
6	29/01/2018 746 133,00

Unit commissioning (Gypsum Incl.)	
1	30/07/2021 783 603,90
2	28/01/2022 821 074,80
3	30/07/2022 858 545,70
4	28/01/2023 896 016,60
5	30/07/2023 933 487,50
6	28/01/2024 970 958,40

After shift 36: Northern stack load 62%  
 Southern stack load 38%

**Northern & Southern stacker combined**

Shift No.	CHAIN m	Volume m <sup>3</sup>	Cumulative Volume m <sup>3</sup>	Average area m <sup>2</sup>	Deposition rate (m <sup>3</sup> /month)	Time (month)	Cum (Months)	Life Years	Date	Date with toe of ash stack included
1	0	0	305 833	0	0	0,00	0	0,0	01/08/2015	
2	66	73 847	379 681	559	124 356	0,53	2,39	0,2	12/10/2015	
3	132	98 056	1 372 309	16 218	248 711	0,39	8,10	0,7	03/04/2016	
4	198	114 598	2 549 277	18 975	373 067	0,31	12,53	1,0	16/08/2016	
5	264	132 373	3 914 933	21 919	373 067	0,35	16,19	1,3	05/12/2016	
6	330	151 583	5 484 672	25 114	497 422	0,30	19,81	1,7	25/03/2017	
7	396	172 074	7 273 145	28 524	497 422	0,35	23,40	2,0	12/07/2017	
8	462	195 336	9 302 429	32 374	621 778	0,31	26,81	2,2	24/10/2017	
9	528	219 870	11 598 437	36 455	746 133	0,29	30,44	2,5	11/02/2018	
10	594	244 198	14 162 555	40 512	746 133	0,33	33,88	2,8	27/05/2018	
<b>11</b>	<b>660</b>	<b>269 388</b>	<b>17 000 467</b>	<b>44 712</b>	<b>746 133</b>	<b>0,36</b>	<b>37,68</b>	<b>3,1</b>	<b>20/09/2018</b>	21/06/2019
12	720	292 680	19 821 185	48 592	746 133	0,39	41,46	3,5	13/01/2019	
13	780	313 522	22 866 798	52 107	746 133	0,42	45,54	3,8	17/05/2019	
14	840	330 040	26 094 557	54 876	746 133	0,44	49,87	4,2	25/09/2019	
15	900	345 958	29 482 351	57 527	746 133	0,46	54,41	4,5	10/02/2020	
16	960	361 666	33 027 747	60 146	746 133	0,48	59,16	4,9	04/07/2020	
17	1 020	375 839	36 725 530	62 532	746 133	0,50	64,12	5,3	02/12/2020	
18	1 080	379 636	40 510 631	63 252	746 133	0,51	69,19	5,8	05/05/2021	
19	1 140	381 652	44 318 405	63 592	783 604	0,49	74,17	6,2	04/10/2021	
20	1 200	383 439	48 146 114	63 903	821 075	0,47	78,99	6,6	27/02/2022	
21	1 260	384 463	51 985 421	64 068	821 075	0,47	83,66	7,0	19/07/2022	
22	1 320	385 124	55 834 208	64 182	858 546	0,45	88,15	7,3	03/12/2022	
<b>23</b>	<b>1 380</b>	<b>384 864</b>	<b>59 684 810</b>	<b>64 147</b>	<b>896 017</b>	<b>0,43</b>	<b>92,52</b>	<b>7,7</b>	<b>15/04/2023</b>	29/02/2024





# Jones & Wagener

Engineering & Environmental Consultants

59 Bevan Road PO Box 1434 Rivonia 2128 South Africa  
 tel:0027 11 519 0200 www.jaws.co.za email:post@jaws.co.za

Client:  
Job Des.

Eskom  
 Conceptual Modelling for Medupi Power station  
 Northern Ash Dump Facility

Job No:  
Sheet No:  
Made by:  
Date:

G145/00  
1  
SL  
23/11/2017

24	1 440	385 523	63 537 031	64 242	933 488	0,41	96,79	8,1	22/08/2023	
25	1 500	385 948	67 394 641	64 318	933 488	0,41	100,92	8,4	26/12/2023	
26	1 560	387 197	71 260 149	64 524	970 958	0,40	104,93	8,7	26/04/2024	
27	1 620	389 227	75 142 228	64 847	970 958	0,40	108,93	9,1	26/08/2024	
28	1 680	391 912	79 048 079	65 290	970 958	0,40	112,95	9,4	26/12/2024	
29	1 740	395 156	82 983 814	65 826	970 958	0,41	117,00	9,8	28/04/2025	
30	1 800	398 636	86 955 113	66 423	970 958	0,41	121,09	10,1	31/08/2025	
31	1 860	400 882	90 950 981	66 784	970 958	0,41	125,21	10,4	03/01/2026	
32	1 920	403 984	94 976 145	67 299	970 958	0,42	129,36	10,8	09/05/2026	
33	1 980	406 198	99 028 792	67 685	970 958	0,42	133,53	11,1	13/09/2026	
34	2 040	409 037	103 106 670	68 154	970 958	0,42	137,73	11,5	19/01/2027	
35	2 100	411 277	107 209 147	68 529	970 958	0,42	141,95	11,8	27/05/2027	
<b>36</b>	<b>2 160</b>	<b>414 853</b>	<b>111 339 259</b>	<b>69 102</b>	<b>970 958</b>	<b>0,43</b>	<b>146,21</b>	<b>12,2</b>	<b>04/10/2027</b>	27/08/2028
37	2 220	416 685	115 502 644	69 446	970 958	0,43	150,50	12,5	11/02/2028	
38	2 280	415 786	119 667 135	69 315	970 958	0,43	154,79	12,9	21/06/2028	
39	2 340	410 640	123 804 317	68 518	970 958	0,42	159,05	13,3	28/10/2028	
40	2 400	398 486	127 850 367	66 546	970 958	0,41	163,21	13,6	04/03/2029	
41	2 460	376 736	131 722 096	63 009	970 958	0,39	167,20	13,9	03/07/2029	
42	2 520	346 049	135 326 769	57 955	970 958	0,36	170,91	14,2	24/10/2029	
43	2 580	321 506	138 644 303	53 762	970 958	0,33	174,33	14,5	05/02/2030	
44	2 640	306 678	141 769 805	51 210	970 958	0,32	177,55	14,8	14/05/2030	
45	2 700	301 531	144 798 626	50 254	970 958	0,31	180,67	15,1	17/08/2030	
46	2 760	301 592	147 812 270	50 241	970 958	0,31	183,77	15,3	19/11/2030	
47	2 820	302 240	150 835 147	50 374	970 958	0,31	186,89	15,6	22/02/2031	
<b>48</b>	<b>2 880</b>	<b>302 198</b>	<b>153 857 802</b>	<b>50 371</b>	<b>970 958</b>	<b>0,31</b>	<b>190,00</b>	<b>15,8</b>	<b>28/05/2031</b>	24/02/2032
49	2 940	301 582	156 875 536	50 264	970 958	0,31	193,11	16,1	30/08/2031	
50	3 000	301 878	159 891 516	50 314	970 958	0,31	196,21	16,4	03/12/2031	
51	3 060	303 167	162 915 182	50 518	970 958	0,31	199,33	16,6	06/03/2032	
52	3 120	304 909	165 954 774	50 800	970 958	0,31	202,46	16,9	10/06/2032	
53	3 180	306 241	169 011 323	51 030	970 958	0,32	205,61	17,1	13/09/2032	
54	3 240	308 912	172 086 902	51 458	970 958	0,32	208,77	17,4	19/12/2032	
55	3 300	310 127	175 184 581	51 682	970 958	0,32	211,96	17,7	26/03/2033	
56	3 360	310 844	178 290 290	51 814	970 958	0,32	215,16	17,9	01/07/2033	
57	3 420	311 606	181 402 989	51 922	970 958	0,32	218,37	18,2	07/10/2033	
58	3 480	297 790	184 469 639	49 827	970 958	0,31	221,53	18,5	11/01/2034	
<b>59</b>	<b>3 540</b>	<b>261 832</b>	<b>187 269 105</b>	<b>44 003</b>	<b>970 958</b>	<b>0,27</b>	<b>224,41</b>	<b>18,7</b>	<b>08/04/2034</b>	20/10/2034
Toe	3 810	1 225	193 315 105	453	970 958	0,00	230,64	19,2	15/10/2034	



# Jones & Wagener

Engineering & Environmental Consultants

59 Bevan Road PO Box 1434 Rivonia 2128 South Africa  
 tel:0027 11 519 0200 www.jaws.co.za email:post@jaws.co.za

Client:  
 Job Des.

Eskom  
 Conceptual Modelling for Medupi Power station  
 Northern Ash Dump Facility

Job No:  
 Sheet No:  
 Made by:  
 Date:

G145/00  
 1  
 SL  
 23/11/2017

## Northern stacker

36	2 160		111 339 259				146,21	12,2	04/10/2027
37	2 220	2 021 057	113 360 316	33 780	601 994	0,34	149,57	12,5	17/01/2028
38	2 280	2 034 805	115 395 121	33 955	601 994	0,34	152,95	12,7	28/04/2028
39	2 340	2 046 836	117 441 957	34 178	601 994	0,34	156,35	13,0	10/08/2028
40	2 400	2 059 292	119 501 249	34 415	601 994	0,34	159,77	13,3	22/11/2028
41	2 460	2 060 546	121 561 795	34 325	601 994	0,34	163,19	13,6	06/03/2029
42	2 520	2 056 410	123 618 205	34 213	601 994	0,34	166,61	13,9	18/06/2029
43	2 580	2 055 559	125 673 764	34 290	601 994	0,34	170,02	14,2	30/09/2029
44	2 640	2 060 953	127 734 717	34 395	601 994	0,34	173,44	14,5	12/01/2030
45	2 700	2 062 235	129 796 952	34 354	601 994	0,34	176,87	14,7	26/04/2030
46	2 760	2 061 851	131 858 803	34 397	601 994	0,34	180,29	15,0	08/08/2030
47	2 820	2 070 916	133 929 719	34 474	601 994	0,34	183,73	15,3	21/11/2030
48	<b>2 880</b>	<b>2 067 745</b>	<b>135 997 464</b>	<b>34 467</b>	<b>601 994</b>	<b>0,34</b>	<b>187,17</b>	<b>15,6</b>	<b>05/03/2031</b>
49	2 940	2 062 397	138 059 861	34 328	601 994	0,34	190,60	15,9	18/06/2031
50	3 000	2 057 757	140 117 618	34 308	601 994	0,34	194,01	16,2	30/09/2031
51	3 060	2 061 882	142 179 500	34 455	601 994	0,34	197,44	16,5	12/01/2032
52	3 120	2 072 834	144 252 334	34 628	601 994	0,35	200,88	16,7	25/04/2032
53	3 180	2 083 794	146 336 128	34 808	601 994	0,35	204,34	17,0	09/08/2032
54	3 240	2 095 041	148 431 169	35 007	601 994	0,35	207,82	17,3	23/11/2032
55	3 300	2 109 124	150 540 293	35 178	601 994	0,35	211,33	17,6	09/03/2033
56	3 360	2 113 938	152 654 231	35 294	601 994	0,35	214,84	17,9	24/06/2033
57	3 420	2 121 340	154 775 571	35 401	601 994	0,35	218,36	18,2	09/10/2033
58	3 480	2 076 367	156 851 938	33 364	601 994	0,33	221,81	18,5	22/01/2034
59	<b>3 540</b>	<b>1 835 047</b>	<b>158 686 985</b>	<b>28 517</b>	<b>601 994</b>	<b>0,28</b>	<b>224,86</b>	<b>18,7</b>	<b>25/04/2034</b>
Toe	3 810	3 674 026	162 361 011	26	601 994	0,00	230,96	19,2	27/10/2034

## Southern stacker

36	2 160		111 339 259				146,21	12,2	04/10/2027
37	2 220	1 695 509	113 034 768	28 258	368 964	4,60	150,80	12,6	20/02/2028
38	2 280	1 695 509	114 730 276	28 258	368 964	4,60	155,40	12,9	09/07/2028
39	2 340	1 695 509	116 425 785	28 258	368 964	4,60	159,99	13,3	26/11/2028
40	2 400	1 695 509	118 121 293	28 258	368 964	4,60	164,59	13,7	15/04/2029
41	2 460	1 695 509	119 816 802	28 258	368 964	4,60	169,19	14,1	02/09/2029
42	2 520	1 695 509	121 512 310	28 258	368 964	4,60	173,78	14,5	19/01/2030
43	2 580	1 695 509	123 207 819	28 258	368 964	4,60	178,38	14,9	08/06/2030
44	2 640	1 695 509	124 903 328	28 258	368 964	4,60	182,97	15,2	26/10/2030
45	2 700	1 695 509	126 598 836	28 258	368 964	4,60	187,57	15,6	15/03/2031
46	2 760	1 695 509	128 294 345	28 258	368 964	4,60	192,16	16,0	01/08/2031
Toe	3 810	14 206 777	142 501 122	0	368 964	39	230,67	19,2	16/10/2034



# Jones & Wagener

Engineering & Environmental Consultants

59 Bevan Road PO Box 1434 Rivonia 2128 South Africa  
 tel:0027 11 519 0200 www.jaws.co.za email:post@jaws.co.za

Client:  
 Job Des.

Eskom  
 Conceptual Modelling for Medupi Power station  
 Northern Ash Dump Facility

Job No:  
 Sheet No:  
 Made by:  
 Date:

G145/00  
 1  
 SL  
 23/11/2017

Detailed calcs:

**North and south stacker combined**

Shift No.	CHAIN m	Volume m <sup>3</sup>	Cumulative Volume m <sup>3</sup>	Average area m <sup>2</sup>	Deposition rate (m <sup>3</sup> /month)	Time (month)	Cum (Months)	Life Years	Date
1,00	0	0	305 833,08	0	0	0	0,00	0	01/08/2015
2,00	66	73 847	379 680,52	559	124 356	0,527	2,39	0,200	12/10/2015
2,09	72	80 512	460 192,34	12 863	124 356	0,647	3,04	0,254	01/11/2015
2,18	78	84 330	544 522,10	13 737	124 356	0,678	3,72	0,310	22/11/2015
2,27	84	85 911	630 432,90	14 187	124 356	0,691	4,41	0,368	13/12/2015
2,36	90	87 440	717 872,78	14 446	124 356	0,703	5,11	0,426	03/01/2016
2,45	96	88 932	806 804,69	14 698	124 356	0,715	5,83	0,486	25/01/2016
2,55	102	90 433	897 237,87	14 947	248 711	0,364	6,19	0,516	05/02/2016
2,64	108	91 955	989 192,70	15 199	248 711	0,370	6,56	0,547	16/02/2016
2,73	114	93 482	1 082 674,45	15 453	248 711	0,376	6,94	0,578	28/02/2016
2,82	120	95 019	1 177 693,25	15 708	248 711	0,382	7,32	0,610	10/03/2016
2,91	126	96 560	1 274 252,95	15 965	248 711	0,388	7,71	0,642	22/03/2016
3,00	132	98 056	1 372 309,28	16 218	248 711	0,394	8,10	0,675	03/04/2016
3,09	138	99 517	1 471 825,78	16 464	248 711	0,400	8,50	0,709	15/04/2016
3,18	144	100 981	1 572 807,18	16 708	248 711	0,406	8,91	0,742	27/04/2016
3,27	150	102 459	1 675 265,88	16 953	248 711	0,412	9,32	0,777	10/05/2016
3,36	156	103 941	1 779 207,08	17 200	248 711	0,418	9,74	0,812	23/05/2016
3,45	162	105 420	1 884 626,58	17 447	248 711	0,424	10,16	0,847	05/06/2016
3,55	168	106 915	1 991 541,28	17 695	248 711	0,430	10,59	0,883	18/06/2016
3,64	174	108 451	2 099 992,68	17 947	248 711	0,436	11,03	0,919	01/07/2016
3,73	180	110 014	2 210 006,68	18 205	248 711	0,442	11,47	0,956	14/07/2016
3,82	186	111 573	2 321 579,58	18 466	248 711	0,449	11,92	0,993	28/07/2016
3,91	192	113 099	2 434 678,78	18 723	373 067	0,303	12,22	1,019	06/08/2016
4,00	198	114 598	2 549 276,68	18 975	373 067	0,307	12,53	1,044	16/08/2016
4,09	204	116 114	2 665 390,38	19 226	373 067	0,311	12,84	1,070	25/08/2016
4,18	210	117 682	2 783 072,68	19 483	373 067	0,315	13,16	1,096	04/09/2016
4,27	216	119 300	2 902 372,38	19 749	373 067	0,320	13,48	1,123	13/09/2016
4,36	222	120 929	3 023 301,58	20 019	373 067	0,324	13,80	1,150	23/09/2016
4,45	228	122 539	3 145 840,38	20 289	373 067	0,328	14,13	1,177	03/10/2016
4,55	234	124 115	3 269 955,48	20 554	373 067	0,333	14,46	1,205	13/10/2016
4,64	240	125 689	3 395 644,88	20 817	373 067	0,337	14,80	1,233	24/10/2016
4,73	246	127 302	3 522 947,08	21 083	373 067	0,341	15,14	1,262	03/11/2016
4,82	252	128 957	3 651 903,78	21 355	373 067	0,346	15,49	1,290	14/11/2016
4,91	258	130 656	3 782 559,28	21 634	373 067	0,350	15,84	1,320	24/11/2016
5,00	264	132 373	3 914 932,68	21 919	373 067	0,355	16,19	1,349	05/12/2016
5,09	270	134 069	4 049 001,78	22 204	373 067	0,359	16,55	1,379	16/12/2016
5,18	276	135 732	4 184 734,08	22 483	373 067	0,364	16,91	1,410	27/12/2016
5,27	282	137 399	4 322 133,38	22 761	373 067	0,368	17,28	1,440	07/01/2017
5,36	288	139 097	4 461 229,98	23 041	373 067	0,373	17,66	1,471	19/01/2017
5,45	294	140 834	4 602 063,88	23 328	373 067	0,378	18,03	1,503	30/01/2017
5,55	300	142 615	4 744 678,58	23 621	497 422	0,287	18,32	1,527	08/02/2017
5,64	306	144 413	4 889 091,68	23 919	497 422	0,290	18,61	1,551	17/02/2017
5,73	312	146 209	5 035 300,48	24 218	497 422	0,294	18,90	1,575	25/02/2017
5,82	318	147 998	5 183 298,08	24 517	497 422	0,298	19,20	1,600	07/03/2017
5,91	324	149 791	5 333 088,78	24 816	497 422	0,301	19,50	1,625	16/03/2017
6,00	330	151 583	5 484 671,78	25 114	497 422	0,305	19,81	1,651	25/03/2017



# Jones & Wagener

Engineering & Environmental Consultants

59 Bevan Road PO Box 1434 Rivonia 2128 South Africa  
 tel: 0027 11 519 0200 www.jaws.co.za email: post@jaws.co.za

Client:  
 Job Des.

Eskom  
 Conceptual Modelling for Medupi Power station  
 Northern Ash Dump Facility

Job No:  
 Sheet No:  
 Made by:  
 Date:

G145/00  
 1  
 SL  
 23/11/2017

6,09	336	153 345	5 638 016,68	25 411	497 422	0,308	20,12	1,676	03/04/2017
6,18	342	155 069	5 793 085,18	25 701	497 422	0,312	20,43	1,702	13/04/2017
6,27	348	156 801	5 949 886,18	25 989	497 422	0,315	20,74	1,729	22/04/2017
6,36	354	158 628	6 108 513,98	26 286	497 422	0,319	21,06	1,755	02/05/2017
6,45	360	160 567	6 269 080,78	26 600	497 422	0,323	21,38	1,782	12/05/2017
6,55	366	162 543	6 431 623,28	26 926	497 422	0,327	21,71	1,809	22/05/2017
6,64	372	164 490	6 596 113,38	27 253	497 422	0,331	22,04	1,837	01/06/2017
6,73	378	166 415	6 762 528,58	27 575	497 422	0,335	22,38	1,865	11/06/2017
6,82	384	168 329	6 930 857,38	27 895	497 422	0,338	22,71	1,893	21/06/2017
6,91	390	170 213	7 101 070,68	28 212	497 422	0,342	23,06	1,921	02/07/2017
<b>7,00</b>	<b>396</b>	<b>172 074</b>	<b>7 273 144,58</b>	<b>28 524</b>	<b>497 422</b>	<b>0,346</b>	<b>23,40</b>	<b>1,950</b>	<b>12/07/2017</b>
7,09	402	173 969	7 447 113,38	28 837	497 422	0,350	23,75	1,979	23/07/2017
7,18	408	175 951	7 623 064,48	29 160	497 422	0,354	24,11	2,009	03/08/2017
7,27	414	178 024	7 801 088,18	29 498	621 778	0,286	24,39	2,033	11/08/2017
7,36	420	180 132	7 981 219,68	29 846	621 778	0,290	24,68	2,057	20/08/2017
7,45	426	182 222	8 163 441,48	30 196	621 778	0,293	24,98	2,081	29/08/2017
7,55	432	184 330	8 347 771,08	30 546	621 778	0,296	25,27	2,106	07/09/2017
7,64	438	186 501	8 534 272,08	30 903	621 778	0,300	25,57	2,131	16/09/2017
7,73	444	188 723	8 722 995,38	31 269	621 778	0,304	25,87	2,156	26/09/2017
7,82	450	190 947	8 913 942,68	31 639	621 778	0,307	26,18	2,182	05/10/2017
7,91	456	193 150	9 107 093,08	32 008	621 778	0,311	26,49	2,208	14/10/2017
<b>8,00</b>	<b>462</b>	<b>195 336</b>	<b>9 302 428,78</b>	<b>32 374</b>	<b>621 778</b>	<b>0,314</b>	<b>26,81</b>	<b>2,234</b>	<b>24/10/2017</b>
8,09	468	197 546	9 499 974,58	32 740	621 778	0,318	27,12	2,260	03/11/2017
8,18	474	199 833	9 699 807,08	33 115	621 778	0,321	27,45	2,287	12/11/2017
8,27	480	202 162	9 901 968,68	33 500	621 778	0,325	27,77	2,314	22/11/2017
8,36	486	204 439	10 106 407,78	33 883	621 778	0,329	28,10	2,342	02/12/2017
8,45	492	206 628	10 313 036,08	34 256	621 778	0,332	28,43	2,369	12/12/2017
8,55	498	208 758	10 521 794,08	34 616	621 778	0,336	28,77	2,397	23/12/2017
8,64	504	210 866	10 732 660,08	34 969	621 778	0,339	29,11	2,426	02/01/2018
8,73	510	213 027	10 945 687,08	35 324	621 778	0,343	29,45	2,454	12/01/2018
8,82	516	215 288	11 160 975,08	35 693	621 778	0,346	29,80	2,483	23/01/2018
8,91	522	217 592	11 378 567,08	36 073	621 778	0,350	30,15	2,512	02/02/2018
<b>9,00</b>	<b>528</b>	<b>219 870</b>	<b>11 598 437,08</b>	<b>36 455</b>	<b>746 133</b>	<b>0,295</b>	<b>30,44</b>	<b>2,537</b>	<b>11/02/2018</b>
9,09	534	222 115	11 820 552,08	36 832	746 133	0,298	30,74	2,562	20/02/2018
9,18	540	224 338	12 044 890,08	37 204	746 133	0,301	31,04	2,587	02/03/2018
9,27	546	226 548	12 271 438,08	37 574	746 133	0,304	31,34	2,612	11/03/2018
9,36	552	228 733	12 500 171,08	37 940	746 133	0,307	31,65	2,637	20/03/2018
9,45	558	230 883	12 731 054,08	38 301	746 133	0,309	31,96	2,663	30/03/2018
9,55	564	233 023	12 964 077,08	38 659	746 133	0,312	32,27	2,689	08/04/2018
9,64	570	235 200	13 199 277,08	39 019	746 133	0,315	32,59	2,716	18/04/2018
9,73	576	237 436	13 436 713,08	39 386	746 133	0,318	32,90	2,742	27/04/2018
9,82	582	239 698	13 676 411,08	39 761	746 133	0,321	33,23	2,769	07/05/2018
9,91	588	241 946	13 918 357,08	40 137	746 133	0,324	33,55	2,796	17/05/2018
<b>10,00</b>	<b>594</b>	<b>244 198</b>	<b>14 162 555,08</b>	<b>40 512</b>	<b>746 133</b>	<b>0,327</b>	<b>33,88</b>	<b>2,823</b>	<b>27/05/2018</b>



# Jones & Wagener

Engineering & Environmental Consultants

59 Bevan Road PO Box 1434 Rivonia 2128 South Africa  
tel:0027 11 519 0200 www.jaws.co.za email:post@jaws.co.za

Client:  
Job Des.

Eskom  
Conceptual Modelling for Medupi Power station  
Northern Ash Dump Facility

Job No:  
Sheet No:  
Made by:  
Date:

G145/00  
1  
SL  
23/11/2017

10,09	600	246 499	14 409 054,08	40 891	746 133	0,330	34,21	2,851	06/06/2018
10,18	606	248 853	14 657 907,08	41 279	746 133	0,334	34,54	2,878	16/06/2018
10,27	612	251 221	14 909 128,08	41 673	746 133	0,337	34,88	2,906	26/06/2018
10,36	618	253 538	15 162 666,08	42 063	746 133	0,340	35,22	2,935	07/07/2018
10,45	624	255 777	15 418 443,08	42 443	746 133	0,343	35,56	2,963	17/07/2018
10,55	630	257 961	15 676 404,08	42 812	746 133	0,346	35,91	2,992	28/07/2018
10,64	636	260 176	15 936 580,08	43 178	746 133	0,349	36,25	3,021	07/08/2018
10,73	642	262 492	16 199 072,08	43 556	746 133	0,352	36,61	3,051	18/08/2018
10,82	648	264 850	16 463 922,08	43 945	746 133	0,355	36,96	3,080	29/08/2018
10,91	654	267 157	16 731 079,08	44 334	746 133	0,358	37,32	3,110	09/09/2018
<b>11,00</b>	<b>660</b>	<b>269 388</b>	<b>17 000 467,08</b>	<b>44 712</b>	<b>746 133</b>	<b>0,361</b>	<b>37,68</b>	<b>3,140</b>	<b>20/09/2018</b>
11,10	666	271 594	17 272 061,08	45 082	746 133	0,364	38,04	3,170	01/10/2018
11,20	672	273 830	17 545 891,08	45 452	746 133	0,367	38,41	3,201	12/10/2018
11,30	678	276 113	17 822 004,08	45 829	746 133	0,370	38,78	3,232	23/10/2018
11,40	684	278 425	18 100 429,08	46 212	746 133	0,373	39,15	3,263	03/11/2018
11,50	690	280 763	18 381 192,08	46 599	746 133	0,376	39,53	3,294	15/11/2018
11,60	696	283 168	18 664 360,08	46 994	746 133	0,380	39,91	3,326	26/11/2018
11,70	702	285 637	18 949 997,08	47 400	746 133	0,383	40,29	3,358	08/12/2018
11,80	708	288 082	19 238 079,08	47 810	746 133	0,386	40,68	3,390	20/12/2018
11,90	714	290 426	19 528 505,08	48 209	746 133	0,389	41,07	3,422	01/01/2019
<b>12,00</b>	<b>720</b>	<b>292 680</b>	<b>19 821 185,08</b>	<b>48 592</b>	<b>746 133</b>	<b>0,392</b>	<b>41,46</b>	<b>3,455</b>	<b>13/01/2019</b>
12,10	726	294 907	20 116 092,08	48 966	746 133	0,395	41,86	3,488	25/01/2019
12,20	732	297 144	20 413 236,08	49 338	746 133	0,398	42,25	3,521	06/02/2019
12,30	738	299 377	20 712 613,08	49 710	746 133	0,401	42,66	3,555	18/02/2019
12,40	744	301 576	21 014 189,08	50 079	746 133	0,404	43,06	3,588	02/03/2019
12,50	750	303 715	21 317 904,08	50 441	746 133	0,407	43,47	3,622	15/03/2019
12,60	756	305 819	21 623 723,08	50 795	746 133	0,410	43,88	3,656	27/03/2019
12,70	762	307 891	21 931 614,08	51 143	746 133	0,413	44,29	3,691	09/04/2019
12,80	768	309 895	22 241 509,08	51 482	746 133	0,415	44,70	3,725	21/04/2019
12,90	774	311 767	22 553 276,08	51 805	746 133	0,418	45,12	3,760	04/05/2019
<b>13,00</b>	<b>780</b>	<b>313 522</b>	<b>22 866 798,08</b>	<b>52 107</b>	<b>746 133</b>	<b>0,420</b>	<b>45,54</b>	<b>3,795</b>	<b>17/05/2019</b>
13,10	786	315 241	23 182 039,08	52 397	746 133	0,422	45,97	3,830	30/05/2019
13,20	792	316 965	23 499 004,08	52 684	746 133	0,425	46,39	3,866	12/06/2019
13,30	798	318 691	23 817 695,08	52 971	746 133	0,427	46,82	3,901	25/06/2019
13,40	804	320 396	24 138 091,08	53 257	746 133	0,429	47,25	3,937	08/07/2019
13,50	810	322 066	24 460 157,08	53 539	746 133	0,432	47,68	3,973	21/07/2019
13,60	816	323 696	24 783 853,08	53 814	746 133	0,434	48,11	4,009	03/08/2019
13,70	822	325 301	25 109 154,08	54 083	746 133	0,436	48,55	4,046	16/08/2019
13,80	828	326 891	25 436 045,08	54 349	746 133	0,438	48,99	4,082	30/08/2019
13,90	834	328 472	25 764 517,08	54 614	746 133	0,440	49,43	4,119	12/09/2019
<b>14,00</b>	<b>840</b>	<b>330 040</b>	<b>26 094 557,08</b>	<b>54 876</b>	<b>746 133</b>	<b>0,442</b>	<b>49,87</b>	<b>4,156</b>	<b>25/09/2019</b>
14,10	846	331 609	26 426 166,08	55 137	746 133	0,444	50,31	4,193	09/10/2019
14,20	852	333 196	26 759 362,08	55 400	746 133	0,447	50,76	4,230	22/10/2019
14,30	858	334 788	27 094 150,08	55 665	746 133	0,449	51,21	4,267	05/11/2019
14,40	864	336 374	27 430 524,08	55 930	746 133	0,451	51,66	4,305	19/11/2019
14,50	870	337 983	27 768 507,08	56 196	746 133	0,453	52,11	4,343	03/12/2019
14,60	876	339 595	28 108 102,08	56 465	746 133	0,455	52,57	4,381	16/12/2019
14,70	882	341 174	28 449 276,08	56 731	746 133	0,457	53,02	4,419	30/12/2019
14,80	888	342 753	28 792 029,08	56 994	746 133	0,459	53,48	4,457	13/01/2020
14,90	894	344 364	29 136 393,08	57 260	746 133	0,462	53,95	4,495	27/01/2020
<b>15,00</b>	<b>900</b>	<b>345 958</b>	<b>29 482 351,08</b>	<b>57 527</b>	<b>746 133</b>	<b>0,464</b>	<b>54,41</b>	<b>4,534</b>	<b>10/02/2020</b>
15,10	906	347 473	29 829 824,08	57 786	746 133	0,466	54,88	4,573	25/02/2020
15,20	912	348 951	30 178 775,08	58 035	746 133	0,468	55,34	4,612	10/03/2020



# Jones & Wagener

Engineering & Environmental Consultants

59 Bevan Road PO Box 1434 Rivonia 2128 South Africa  
 tel: 0027 11 519 0200 www.jaws.co.za email: post@jaws.co.za

Client:  
Job Des.

Eskom  
 Conceptual Modelling for Medupi Power station  
 Northern Ash Dump Facility

Job No:  
Sheet No:  
Made by:  
Date:

G145/00  
1  
SL  
23/11/2017

15,30	918	350 507	30 529 282,08	58 288	746 133	0,470	55,81	4,651	24/03/2020
15,40	924	352 154	30 881 436,08	58 555	746 133	0,472	56,28	4,690	07/04/2020
15,50	930	353 792	31 235 228,08	58 829	746 133	0,474	56,76	4,730	22/04/2020
15,60	936	355 365	31 590 593,08	59 096	746 133	0,476	57,23	4,770	06/05/2020
15,70	942	356 914	31 947 507,08	59 357	746 133	0,478	57,71	4,809	21/05/2020
15,80	948	358 492	32 305 999,08	59 617	746 133	0,480	58,19	4,849	05/06/2020
15,90	954	360 082	32 666 081,08	59 881	746 133	0,483	58,68	4,890	19/06/2020
<b>16,00</b>	<b>960</b>	<b>361 666</b>	<b>33 027 747,08</b>	<b>60 146</b>	<b>746 133</b>	<b>0,485</b>	<b>59,16</b>	<b>4,930</b>	<b>04/07/2020</b>
16,10	966	363 250	33 390 997,08	60 410	746 133	0,487	59,65	4,971	19/07/2020
16,20	972	364 832	33 755 829,08	60 674	746 133	0,489	60,14	5,011	03/08/2020
16,30	978	366 373	34 122 202,08	60 934	746 133	0,491	60,63	5,052	18/08/2020
16,40	984	367 844	34 490 046,08	61 185	746 133	0,493	61,12	5,093	02/09/2020
16,50	990	369 262	34 859 308,08	61 426	746 133	0,495	61,62	5,135	17/09/2020
16,60	996	370 630	35 229 938,08	61 658	746 133	0,497	62,11	5,176	02/10/2020
16,70	1002	371 952	35 601 890,08	61 882	746 133	0,499	62,61	5,218	17/10/2020
16,80	1008	373 252	35 975 142,08	62 100	746 133	0,500	63,11	5,259	01/11/2020
16,90	1014	374 549	36 349 691,08	62 317	746 133	0,502	63,61	5,301	16/11/2020
<b>17,00</b>	<b>1020</b>	<b>375 839</b>	<b>36 725 530,08</b>	<b>62 532</b>	<b>746 133</b>	<b>0,504</b>	<b>64,12</b>	<b>5,343</b>	<b>02/12/2020</b>
17,10	1026	376 944	37 102 474,08	62 732	746 133	0,505	64,62	5,385	17/12/2020
17,20	1032	377 653	37 480 127,08	62 883	746 133	0,506	65,13	5,427	01/01/2021
17,30	1038	378 002	37 858 129,08	62 971	746 133	0,507	65,63	5,470	17/01/2021
17,40	1044	378 227	38 236 356,08	63 019	746 133	0,507	66,14	5,512	01/02/2021
17,50	1050	378 478	38 614 834,08	63 059	746 133	0,507	66,65	5,554	17/02/2021
17,60	1056	378 712	38 993 546,08	63 099	746 133	0,508	67,16	5,596	04/03/2021
17,70	1062	378 926	39 372 472,08	63 137	746 133	0,508	67,66	5,639	20/03/2021
17,80	1068	379 141	39 751 613,08	63 172	746 133	0,508	68,17	5,681	04/04/2021
17,90	1074	379 382	40 130 995,08	63 210	746 133	0,508	68,68	5,723	20/04/2021
<b>18,00</b>	<b>1080</b>	<b>379 636</b>	<b>40 510 631,08</b>	<b>63 252</b>	<b>746 133</b>	<b>0,509</b>	<b>69,19</b>	<b>5,766</b>	<b>05/05/2021</b>
18,10	1086	379 884	40 890 515,08	63 293	746 133	0,509	69,70	5,808	21/05/2021
18,20	1092	380 139	41 270 654,08	63 335	746 133	0,509	70,21	5,851	05/06/2021
18,30	1098	380 382	41 651 036,08	63 377	746 133	0,510	70,72	5,893	21/06/2021
18,40	1104	380 568	42 031 604,08	63 413	746 133	0,510	71,23	5,936	06/07/2021
18,50	1110	380 684	42 412 288,08	63 438	746 133	0,510	71,74	5,978	22/07/2021
18,60	1116	380 801	42 793 089,08	63 457	783 604	0,486	72,22	6,019	05/08/2021
18,70	1122	380 987	43 174 076,08	63 482	783 604	0,486	72,71	6,059	20/08/2021
18,80	1128	381 226	43 555 302,08	63 518	783 604	0,487	73,20	6,100	04/09/2021
18,90	1134	381 451	43 936 753,08	63 556	783 604	0,487	73,68	6,140	19/09/2021
<b>19,00</b>	<b>1140</b>	<b>381 652</b>	<b>44 318 405,08</b>	<b>63 592</b>	<b>783 604</b>	<b>0,487</b>	<b>74,17</b>	<b>6,181</b>	<b>04/10/2021</b>
19,10	1146	381 869	44 700 274,08	63 627	783 604	0,487	74,66	6,222	18/10/2021
19,20	1152	382 129	45 082 403,08	63 667	783 604	0,488	75,15	6,262	02/11/2021
19,30	1158	382 389	45 464 792,08	63 710	783 604	0,488	75,63	6,303	17/11/2021
19,40	1164	382 580	45 847 372,08	63 747	783 604	0,488	76,12	6,344	02/12/2021
19,50	1 170	382 711	46 230 083,08	63 774	783 604	0,488	76,61	6,384	17/12/2021
19,60	1176	382 857	46 612 940,08	63 797	783 604	0,489	77,10	6,425	01/01/2022
19,70	1182	383 066	46 996 006,08	63 827	783 604	0,489	77,59	6,466	15/01/2022
19,80	1188	383 273	47 379 279,08	63 862	821 075	0,467	78,06	6,505	30/01/2022
19,90	1194	383 396	47 762 675,08	63 889	821 075	0,467	78,52	6,543	13/02/2022
<b>20,00</b>	<b>1200</b>	<b>383 439</b>	<b>48 146 114,08</b>	<b>63 903</b>	<b>821 075</b>	<b>0,467</b>	<b>78,99</b>	<b>6,582</b>	<b>27/02/2022</b>
20,10	1206	383 469	48 529 583,08	63 909	821 075	0,467	79,46	6,621	13/03/2022
20,20	1212	383 520	48 913 103,08	63 916	821 075	0,467	79,92	6,660	27/03/2022
20,30	1218	383 583	49 296 686,08	63 925	821 075	0,467	80,39	6,699	11/04/2022
20,40	1224	383 678	49 680 364,08	63 938	821 075	0,467	80,86	6,738	25/04/2022
20,50	1230	383 822	50 064 186,08	63 958	821 075	0,467	81,32	6,777	09/05/2022



# Jones & Wagener

Engineering & Environmental Consultants

59 Bevan Road PO Box 1434 Rivonia 2128 South Africa  
 tel: 0027 11 519 0200 www.jaws.co.za email: post@jaws.co.za

Client:  
Job Des.

Eskom  
 Conceptual Modelling for Medupi Power station  
 Northern Ash Dump Facility

Job No:  
Sheet No:  
Made by:  
Date:

G145/00  
1  
SL  
23/11/2017

20,60	1236	384 005	50 448 191,08	63 986	821 075	0,468	81,79	6,816	23/05/2022
20,70	1242	384 157	50 832 348,08	64 014	821 075	0,468	82,26	6,855	07/06/2022
20,80	1248	384 256	51 216 604,08	64 034	821 075	0,468	82,73	6,894	21/06/2022
20,90	1254	384 354	51 600 958,08	64 051	821 075	0,468	83,20	6,933	05/07/2022
<b>21,00</b>	<b>1260</b>	<b>384 463</b>	<b>51 985 421,08</b>	<b>64 068</b>	<b>821 075</b>	<b>0,468</b>	<b>83,66</b>	<b>6,972</b>	<b>19/07/2022</b>
21,10	1266	384 560	52 369 981,08	64 085	858 546	0,448	84,11	7,009	02/08/2022
21,20	1272	384 655	52 754 636,08	64 101	858 546	0,448	84,56	7,047	16/08/2022
21,30	1278	384 778	53 139 414,08	64 119	858 546	0,448	85,01	7,084	29/08/2022
21,40	1284	384 899	53 524 313,08	64 140	858 546	0,448	85,46	7,121	12/09/2022
21,50	1290	384 954	53 909 267,08	64 154	858 546	0,448	85,91	7,159	25/09/2022
21,60	1296	384 930	54 294 197,08	64 157	858 546	0,448	86,35	7,196	09/10/2022
21,70	1302	384 893	54 679 090,08	64 152	858 546	0,448	86,80	7,234	23/10/2022
21,80	1308	384 939	55 064 029,08	64 153	858 546	0,448	87,25	7,271	05/11/2022
21,90	1314	385 055	55 449 084,08	64 166	858 546	0,448	87,70	7,308	19/11/2022
<b>22,00</b>	<b>1320</b>	<b>385 124</b>	<b>55 834 208,08</b>	<b>64 182</b>	<b>858 546</b>	<b>0,449</b>	<b>88,15</b>	<b>7,346</b>	<b>03/12/2022</b>
22,10	1326	385 088	56 219 296,08	64 184	858 546	0,449	88,60	7,383	16/12/2022
22,20	1332	385 039	56 604 335,08	64 177	858 546	0,448	89,04	7,420	30/12/2022
22,30	1338	385 059	56 989 394,08	64 175	858 546	0,449	89,49	7,458	13/01/2023
22,40	1344	385 135	57 374 529,08	64 183	858 546	0,449	89,94	7,495	26/01/2023
22,50	1350	385 206	57 759 735,08	64 195	896 017	0,430	90,37	7,531	08/02/2023
22,60	1356	385 207	58 144 942,08	64 201	896 017	0,430	90,80	7,567	21/02/2023
22,70	1362	385 119	58 530 061,08	64 194	896 017	0,430	91,23	7,603	06/03/2023
22,80	1368	384 991	58 915 052,08	64 176	896 017	0,430	91,66	7,638	20/03/2023
22,90	1374	384 894	59 299 946,08	64 157	896 017	0,430	92,09	7,674	02/04/2023
<b>23,00</b>	<b>1380</b>	<b>384 864</b>	<b>59 684 810,08</b>	<b>64 147</b>	<b>896 017</b>	<b>0,430</b>	<b>92,52</b>	<b>7,710</b>	<b>15/04/2023</b>
23,10	1386	384 882	60 069 692,08	64 146	896 017	0,430	92,95	7,746	28/04/2023
23,20	1392	384 940	60 454 632,08	64 152	896 017	0,430	93,38	7,782	11/05/2023
23,30	1398	385 076	60 839 708,08	64 168	896 017	0,430	93,81	7,817	24/05/2023
23,40	1404	385 248	61 224 956,08	64 194	896 017	0,430	94,24	7,853	06/06/2023
23,50	1410	385 325	61 610 281,08	64 214	896 017	0,430	94,67	7,889	19/06/2023
23,60	1416	385 295	61 995 576,08	64 218	896 017	0,430	95,10	7,925	02/07/2023
23,70	1422	385 263	62 380 839,08	64 213	896 017	0,430	95,53	7,961	15/07/2023
23,80	1428	385 290	62 766 129,08	64 213	896 017	0,430	95,96	7,997	28/07/2023
23,90	1434	385 379	63 151 508,08	64 222	933 488	0,413	96,37	8,031	10/08/2023
<b>24,00</b>	<b>1440</b>	<b>385 523</b>	<b>63 537 031,08</b>	<b>64 242</b>	<b>933 488</b>	<b>0,413</b>	<b>96,79</b>	<b>8,065</b>	<b>22/08/2023</b>
24,10	1446	385 672	63 922 703,08	64 266	933 488	0,413	97,20	8,100	04/09/2023
24,20	1452	385 761	64 308 464,08	64 286	933 488	0,413	97,61	8,134	17/09/2023
24,30	1458	385 763	64 694 227,08	64 294	933 488	0,413	98,02	8,169	29/09/2023
24,40	1464	385 713	65 079 940,08	64 290	933 488	0,413	98,44	8,203	12/10/2023
24,50	1470	385 674	65 465 614,08	64 282	933 488	0,413	98,85	8,238	24/10/2023
24,60	1476	385 689	65 851 303,08	64 280	933 488	0,413	99,26	8,272	06/11/2023
24,70	1482	385 735	66 237 038,08	64 285	933 488	0,413	99,68	8,306	18/11/2023
24,80	1488	385 789	66 622 827,08	64 294	933 488	0,413	100,09	8,341	01/12/2023
24,90	1494	385 866	67 008 693,08	64 305	933 488	0,413	100,50	8,375	13/12/2023
<b>25,00</b>	<b>1500</b>	<b>385 948</b>	<b>67 394 641,08</b>	<b>64 318</b>	<b>933 488</b>	<b>0,413</b>	<b>100,92</b>	<b>8,410</b>	<b>26/12/2023</b>
25,10	1506	385 995	67 780 636,08	64 329	933 488	0,413	101,33	8,444	08/01/2024
25,20	1512	386 037	68 166 673,08	64 336	933 488	0,414	101,74	8,479	20/01/2024
25,30	1518	386 106	68 552 779,08	64 345	970 958	0,398	102,14	8,512	01/02/2024
25,40	1524	386 223	68 939 002,08	64 361	970 958	0,398	102,54	8,545	13/02/2024
25,50	1530	386 403	69 325 405,08	64 386	970 958	0,398	102,94	8,578	26/02/2024
25,60	1536	386 634	69 712 039,08	64 420	970 958	0,398	103,34	8,611	09/03/2024
25,70	1542	386 840	70 098 879,08	64 456	970 958	0,398	103,73	8,645	21/03/2024
25,80	1548	386 980	70 485 859,08	64 485	970 958	0,399	104,13	8,678	02/04/2024



# Jones & Wagener

Engineering & Environmental Consultants

59 Bevan Road PO Box 1434 Rivonia 2128 South Africa  
 tel:0027 11 519 0200 www.jaws.co.za email:post@jaws.co.za

Client:  
Job Des.

Eskom  
 Conceptual Modelling for Medupi Power station  
 Northern Ash Dump Facility

Job No:  
Sheet No:  
Made by:  
Date:

G145/00  
1  
SL  
23/11/2017

25,90	1554	387 093	70 872 952,08	64 506	970 958	0,399	104,53	8,711	14/04/2024
<b>26,00</b>	<b>1560</b>	<b>387 197</b>	<b>71 260 149,08</b>	<b>64 524</b>	<b>970 958</b>	<b>0,399</b>	<b>104,93</b>	<b>8,744</b>	<b>26/04/2024</b>
26,10	1566	387 309	71 647 458,08	64 542	970 958	0,399	105,33	8,777	08/05/2024
26,20	1572	387 460	72 034 918,08	64 564	970 958	0,399	105,73	8,811	20/05/2024
26,30	1578	387 662	72 422 580,08	64 594	970 958	0,399	106,13	8,844	02/06/2024
26,40	1584	387 907	72 810 487,08	64 631	970 958	0,400	106,53	8,877	14/06/2024
26,50	1590	388 136	73 198 623,08	64 670	970 958	0,400	106,93	8,911	26/06/2024
26,60	1596	388 305	73 586 928,08	64 703	970 958	0,400	107,33	8,944	08/07/2024
26,70	1602	388 464	73 975 392,08	64 731	970 958	0,400	107,73	8,977	20/07/2024
26,80	1608	388 671	74 364 063,08	64 761	970 958	0,400	108,13	9,011	01/08/2024
26,90	1614	388 938	74 753 001,08	64 801	970 958	0,401	108,53	9,044	14/08/2024
<b>27,00</b>	<b>1620</b>	<b>389 227</b>	<b>75 142 228,08</b>	<b>64 847</b>	<b>970 958</b>	<b>0,401</b>	<b>108,93</b>	<b>9,077</b>	<b>26/08/2024</b>
27,10	1626	389 489	75 531 717,08	64 893	970 958	0,401	109,33	9,111	07/09/2024
27,20	1632	389 695	75 921 412,08	64 932	970 958	0,401	109,73	9,144	19/09/2024
27,30	1638	389 903	76 311 315,08	64 967	970 958	0,402	110,13	9,178	01/10/2024
27,40	1644	390 151	76 701 466,08	65 005	970 958	0,402	110,53	9,211	14/10/2024
27,50	1650	390 416	77 091 882,08	65 047	970 958	0,402	110,94	9,245	26/10/2024
27,60	1656	390 651	77 482 533,08	65 089	970 958	0,402	111,34	9,278	07/11/2024
27,70	1662	390 880	77 873 413,08	65 128	970 958	0,403	111,74	9,312	19/11/2024
27,80	1668	391 189	78 264 602,08	65 172	970 958	0,403	112,14	9,345	02/12/2024
27,90	1674	391 565	78 656 167,08	65 230	970 958	0,403	112,55	9,379	14/12/2024
<b>28,00</b>	<b>1680</b>	<b>391 912</b>	<b>79 048 079,08</b>	<b>65 290</b>	<b>970 958</b>	<b>0,404</b>	<b>112,95</b>	<b>9,413</b>	<b>26/12/2024</b>
28,10	1686	392 178	79 440 257,08	65 341	970 958	0,404	113,36	9,446	07/01/2025
28,20	1692	392 410	79 832 667,08	65 382	970 958	0,404	113,76	9,480	20/01/2025
28,30	1698	392 678	80 225 345,08	65 424	970 958	0,404	114,16	9,514	01/02/2025
28,40	1704	393 013	80 618 358,08	65 474	970 958	0,405	114,57	9,547	13/02/2025
28,50	1710	393 377	81 011 735,08	65 533	970 958	0,405	114,97	9,581	26/02/2025
28,60	1716	393 726	81 405 461,08	65 592	970 958	0,406	115,38	9,615	10/03/2025
28,70	1722	394 055	81 799 516,08	65 648	970 958	0,406	115,79	9,649	22/03/2025
28,80	1728	394 388	82 193 904,08	65 704	970 958	0,406	116,19	9,683	04/04/2025
28,90	1734	394 754	82 588 658,08	65 762	970 958	0,407	116,60	9,716	16/04/2025
<b>29,00</b>	<b>1740</b>	<b>395 156</b>	<b>82 983 814,08</b>	<b>65 826</b>	<b>970 958</b>	<b>0,407</b>	<b>117,00</b>	<b>9,750</b>	<b>28/04/2025</b>
29,10	1746	395 554	83 379 368,08	65 893	970 958	0,407	117,41	9,784	11/05/2025
29,20	1752	395 907	83 775 275,08	65 955	970 958	0,408	117,82	9,818	23/05/2025
29,30	1758	396 228	84 171 503,08	66 011	970 958	0,408	118,23	9,852	05/06/2025
29,40	1764	396 560	84 568 063,08	66 066	970 958	0,408	118,64	9,886	17/06/2025
29,50	1770	396 923	84 964 986,08	66 124	970 958	0,409	119,05	9,920	29/06/2025
29,60	1776	397 290	85 362 276,08	66 184	970 958	0,409	119,45	9,955	12/07/2025
29,70	1 782	397 678	85 759 954,08	66 247	970 958	0,410	119,86	9,989	24/07/2025
29,80	1788	398 089	86 158 043,08	66 314	970 958	0,410	120,27	10,023	06/08/2025
29,90	1794	398 434	86 556 477,08	66 377	970 958	0,410	120,68	10,057	18/08/2025
<b>30,00</b>	<b>1800</b>	<b>398 636</b>	<b>86 955 113,08</b>	<b>66 423</b>	<b>970 958</b>	<b>0,411</b>	<b>121,09</b>	<b>10,091</b>	<b>31/08/2025</b>
30,10	1806	398 735	87 353 848,08	66 448	970 958	0,411	121,51	10,125	12/09/2025
30,20	1812	398 844	87 752 692,08	66 465	970 958	0,411	121,92	10,160	25/09/2025
30,30	1818	399 000	88 151 692,08	66 487	970 958	0,411	122,33	10,194	07/10/2025
30,40	1824	399 166	88 550 858,08	66 514	970 958	0,411	122,74	10,228	20/10/2025
30,50	1830	399 325	88 950 183,08	66 541	970 958	0,411	123,15	10,262	01/11/2025
30,60	1836	399 507	89 349 690,08	66 569	970 958	0,411	123,56	10,297	14/11/2025
30,70	1842	399 763	89 749 453,08	66 606	970 958	0,412	123,97	10,331	26/11/2025
30,80	1848	400 124	90 149 577,08	66 657	970 958	0,412	124,38	10,365	09/12/2025
30,90	1854	400 522	90 550 099,08	66 721	970 958	0,413	124,80	10,400	21/12/2025
<b>31,00</b>	<b>1860</b>	<b>400 882</b>	<b>90 950 981,08</b>	<b>66 784</b>	<b>970 958</b>	<b>0,413</b>	<b>125,21</b>	<b>10,434</b>	<b>03/01/2026</b>
31,10	1866	401 177	91 352 158,08	66 838	970 958	0,413	125,62	10,469	16/01/2026





# Jones & Wagener

Engineering & Environmental Consultants

59 Bevan Road PO Box 1434 Rivonia 2128 South Africa  
 tel:0027 11 519 0200 www.jaws.co.za email:post@jaws.co.za

Client:  
 Job Des.

Eskom  
 Conceptual Modelling for Medupi Power station  
 Northern Ash Dump Facility

Job No:  
 Sheet No:  
 Made by:  
 Date:

G145/00  
 1  
 SL  
 23/11/2017

31,20	1872	401 471	91 753 629,08	66 887	970 958	0,413	126,04	10,503	28/01/2026
31,30	1878	401 785	92 155 414,08	66 938	970 958	0,414	126,45	10,538	10/02/2026
31,40	1884	402 068	92 557 482,08	66 988	970 958	0,414	126,86	10,572	22/02/2026
31,50	1890	402 327	92 959 809,08	67 033	970 958	0,414	127,28	10,607	07/03/2026
31,60	1896	402 606	93 362 415,08	67 078	970 958	0,415	127,69	10,641	20/03/2026
31,70	1902	402 908	93 765 323,08	67 126	970 958	0,415	128,11	10,676	01/04/2026
31,80	1908	403 236	94 168 559,08	67 179	970 958	0,415	128,52	10,710	14/04/2026
31,90	1914	403 602	94 572 161,08	67 237	970 958	0,416	128,94	10,745	26/04/2026
<b>32,00</b>	<b>1920</b>	<b>403 984</b>	<b>94 976 145,08</b>	<b>67 299</b>	<b>970 958</b>	<b>0,416</b>	<b>129,36</b>	<b>10,780</b>	<b>09/05/2026</b>
32,10	1926	404 325	95 380 470,08	67 359	970 958	0,416	129,77	10,814	22/05/2026
32,20	1932	404 585	95 785 055,08	67 409	970 958	0,417	130,19	10,849	03/06/2026
32,30	1938	404 771	96 189 826,08	67 446	970 958	0,417	130,61	10,884	16/06/2026
32,40	1944	404 915	96 594 741,08	67 474	970 958	0,417	131,02	10,919	29/06/2026
32,50	1950	405 084	96 999 825,08	67 500	970 958	0,417	131,44	10,953	11/07/2026
32,60	1956	405 319	97 405 144,08	67 534	970 958	0,417	131,86	10,988	24/07/2026
32,70	1962	405 592	97 810 736,08	67 576	970 958	0,418	132,28	11,023	06/08/2026
32,80	1 968	405 835	98 216 571,08	67 619	970 958	0,418	132,69	11,058	19/08/2026
32,90	1974	406 023	98 622 594,08	67 655	970 958	0,418	133,11	11,093	31/08/2026
<b>33,00</b>	<b>1980</b>	<b>406 198</b>	<b>99 028 792,08</b>	<b>67 685</b>	<b>970 958</b>	<b>0,418</b>	<b>133,53</b>	<b>11,127</b>	<b>13/09/2026</b>
33,10	1986	406 418	99 435 210,08	67 718	970 958	0,419	133,95	11,162	26/09/2026
33,20	1992	406 679	99 841 889,08	67 758	970 958	0,419	134,37	11,197	09/10/2026
33,30	1998	406 968	100 248 857,08	67 804	970 958	0,419	134,79	11,232	21/10/2026
33,40	2004	407 292	100 656 149,08	67 855	970 958	0,419	135,21	11,267	03/11/2026
33,50	2010	407 680	101 063 829,08	67 914	970 958	0,420	135,63	11,302	16/11/2026
33,60	2016	408 060	101 471 889,08	67 978	970 958	0,420	136,05	11,337	29/11/2026
33,70	2022	408 348	101 880 237,08	68 034	970 958	0,421	136,47	11,372	11/12/2026
33,80	2028	408 581	102 288 818,08	68 077	970 958	0,421	136,89	11,407	24/12/2026
33,90	2034	408 815	102 697 633,08	68 116	970 958	0,421	137,31	11,442	06/01/2027
<b>34,00</b>	<b>2040</b>	<b>409 037</b>	<b>103 106 670,08</b>	<b>68 154</b>	<b>970 958</b>	<b>0,421</b>	<b>137,73</b>	<b>11,477</b>	<b>19/01/2027</b>
34,10	2046	409 218	103 515 888,08	68 188	970 958	0,421	138,15	11,513	01/02/2027
34,20	2052	409 381	103 925 269,08	68 217	970 958	0,422	138,57	11,548	13/02/2027
34,30	2058	409 571	104 334 840,08	68 246	970 958	0,422	138,99	11,583	26/02/2027
34,40	2064	409 843	104 744 683,08	68 285	970 958	0,422	139,42	11,618	11/03/2027
34,50	2070	410 162	105 154 845,08	68 334	970 958	0,422	139,84	11,653	24/03/2027
34,60	2076	410 438	105 565 283,08	68 383	970 958	0,423	140,26	11,688	06/04/2027
34,70	2082	410 658	105 975 941,08	68 425	970 958	0,423	140,68	11,724	19/04/2027
34,80	2088	410 863	106 386 804,08	68 460	970 958	0,423	141,11	11,759	02/05/2027
34,90	2094	411 066	106 797 870,08	68 494	970 958	0,423	141,53	11,794	14/05/2027
<b>35,00</b>	<b>2100</b>	<b>411 277</b>	<b>107 209 147,08</b>	<b>68 529</b>	<b>970 958</b>	<b>0,424</b>	<b>141,95</b>	<b>11,830</b>	<b>27/05/2027</b>
35,10	2106	411 502	107 620 649,08	68 565	970 958	0,424	142,38	11,865	09/06/2027
35,20	2112	411 759	108 032 408,08	68 605	970 958	0,424	142,80	11,900	22/06/2027
35,30	2118	412 059	108 444 467,08	68 652	970 958	0,424	143,23	11,936	05/07/2027
35,40	2124	412 384	108 856 851,08	68 704	970 958	0,425	143,65	11,971	18/07/2027
35,50	2130	412 714	109 269 565,08	68 758	970 958	0,425	144,08	12,006	31/07/2027
35,60	2136	413 074	109 682 639,08	68 816	970 958	0,425	144,50	12,042	13/08/2027
35,70	2142	413 481	110 096 120,08	68 880	970 958	0,426	144,93	12,077	26/08/2027
35,80	2148	413 917	110 510 037,08	68 950	970 958	0,426	145,35	12,113	08/09/2027
35,90	2154	414 369	110 924 406,08	69 024	970 958	0,427	145,78	12,148	21/09/2027
<b>36,00</b>	<b>2160</b>	<b>414 853</b>	<b>111 339 259,08</b>	<b>69 102</b>	<b>970 958</b>	<b>0,427</b>	<b>146,21</b>	<b>12,184</b>	<b>04/10/2027</b>
36,10	2166	415 364	111 754 623,08	69 185	970 958	0,428	146,64	12,220	17/10/2027
36,20	2172	415 815	112 170 438,08	69 265	970 958	0,428	147,06	12,255	30/10/2027
36,30	2178	416 136	112 586 574,08	69 329	970 958	0,429	147,49	12,291	12/11/2027
36,40	2184	416 350	113 002 924,08	69 374	970 958	0,429	147,92	12,327	25/11/2027



# Jones & Wagener

Engineering & Environmental Consultants

59 Bevan Road PO Box 1434 Rivonia 2128 South Africa  
 tel: 0027 11 519 0200 www.jaws.co.za email: post@jaws.co.za

Client:  
 Job Des.

Eskom  
 Conceptual Modelling for Medupi Power station  
 Northern Ash Dump Facility

Job No:  
 Sheet No:  
 Made by:  
 Date:

G145/00  
 1  
 SL  
 23/11/2017

36,50	2190	416 498	113 419 422,08	69 404	970 958	0,429	148,35	12,363	08/12/2027
36,60	2196	416 584	113 836 006,08	69 424	970 958	0,429	148,78	12,398	21/12/2027
36,70	2202	416 631	114 252 637,08	69 435	970 958	0,429	149,21	12,434	03/01/2028
36,80	2208	416 656	114 669 293,08	69 441	970 958	0,429	149,64	12,470	16/01/2028
36,90	2214	416 666	115 085 959,08	69 444	970 958	0,429	150,07	12,506	29/01/2028
<b>37,00</b>	<b>2220</b>	<b>416 685</b>	<b>115 502 644,08</b>	<b>69 446</b>	<b>970 958</b>	<b>0,429</b>	<b>150,50</b>	<b>12,541</b>	<b>11/02/2028</b>
37,10	2226	416 762	115 919 406,08	69 454	970 958	0,429	150,93	12,577	24/02/2028
37,20	2232	416 878	116 336 284,08	69 470	970 958	0,429	151,35	12,613	08/03/2028
37,30	2238	416 949	116 753 233,08	69 486	970 958	0,429	151,78	12,649	21/03/2028
37,40	2244	416 874	117 170 107,08	69 485	970 958	0,429	152,21	12,684	03/04/2028
37,50	2250	416 627	117 586 734,08	69 458	970 958	0,429	152,64	12,720	16/04/2028
37,60	2256	416 323	118 003 057,08	69 413	970 958	0,429	153,07	12,756	29/04/2028
37,70	2262	416 174	118 419 231,08	69 375	970 958	0,429	153,50	12,792	12/05/2028
37,80	2268	416 130	118 835 361,08	69 359	970 958	0,429	153,93	12,827	25/05/2028
37,90	2274	415 988	119 251 349,08	69 343	970 958	0,428	154,36	12,863	08/06/2028
<b>38,00</b>	<b>2280</b>	<b>415 786</b>	<b>119 667 135,08</b>	<b>69 315</b>	<b>970 958</b>	<b>0,428</b>	<b>154,79</b>	<b>12,899</b>	<b>21/06/2028</b>
38,10	2286	415 598	120 082 733,08	69 282	970 958	0,428	155,21	12,934	04/07/2028
38,20	2292	415 416	120 498 149,08	69 251	970 958	0,428	155,64	12,970	17/07/2028
38,30	2298	415 174	120 913 323,08	69 216	970 958	0,428	156,07	13,006	30/07/2028
38,40	2304	414 807	121 328 130,08	69 165	970 958	0,427	156,50	13,041	12/08/2028
38,50	2310	414 371	121 742 501,08	69 098	970 958	0,427	156,92	13,077	25/08/2028
38,60	2316	413 875	122 156 376,08	69 021	970 958	0,426	157,35	13,112	07/09/2028
38,70	2322	413 255	122 569 631,08	68 928	970 958	0,426	157,77	13,148	19/09/2028
38,80	2328	412 473	122 982 104,08	68 811	970 958	0,425	158,20	13,183	02/10/2028
38,90	2334	411 573	123 393 677,08	68 671	970 958	0,424	158,62	13,219	15/10/2028
<b>39,00</b>	<b>2340</b>	<b>410 640</b>	<b>123 804 317,08</b>	<b>68 518</b>	<b>970 958</b>	<b>0,423</b>	<b>159,05</b>	<b>13,254</b>	<b>28/10/2028</b>
39,10	2346	409 705	124 214 022,08	68 362	970 958	0,422	159,47	13,289	10/11/2028
39,20	2352	408 784	124 622 806,08	68 207	970 958	0,421	159,89	13,324	23/11/2028
39,30	2358	407 825	125 030 631,08	68 051	970 958	0,420	160,31	13,359	06/12/2028
39,40	2364	406 786	125 437 417,08	67 884	970 958	0,419	160,73	13,394	18/12/2028
39,50	2370	405 616	125 843 033,08	67 700	970 958	0,418	161,15	13,429	31/12/2028
39,60	2376	404 311	126 247 344,08	67 494	970 958	0,416	161,56	13,464	13/01/2029
39,70	2382	402 938	126 650 282,08	67 271	970 958	0,415	161,98	13,498	25/01/2029
39,80	2388	401 531	127 051 813,08	67 039	970 958	0,414	162,39	13,533	07/02/2029
39,90	2394	400 068	127 451 881,08	66 800	970 958	0,412	162,80	13,567	19/02/2029
<b>40,00</b>	<b>2400</b>	<b>398 486</b>	<b>127 850 367,08</b>	<b>66 546</b>	<b>970 958</b>	<b>0,410</b>	<b>163,21</b>	<b>13,601</b>	<b>04/03/2029</b>
40,10	2406	396 748	128 247 115,08	66 270	970 958	0,409	163,62	13,635	16/03/2029
40,20	2412	394 851	128 641 966,08	65 967	970 958	0,407	164,03	13,669	29/03/2029
40,30	2418	392 815	129 034 781,08	65 639	970 958	0,405	164,43	13,703	10/04/2029
40,40	2424	390 674	129 425 455,08	65 291	970 958	0,402	164,84	13,736	22/04/2029
40,50	2430	388 460	129 813 915,08	64 928	970 958	0,400	165,24	13,770	04/05/2029
40,60	2436	386 247	130 200 162,08	64 559	970 958	0,398	165,63	13,803	17/05/2029
40,70	2442	384 042	130 584 204,08	64 191	970 958	0,396	166,03	13,836	29/05/2029
40,80	2448	381 783	130 965 987,08	63 819	970 958	0,393	166,42	13,869	10/06/2029
40,90	2454	379 373	131 345 360,08	63 430	970 958	0,391	166,81	13,901	21/06/2029
<b>41,00</b>	<b>2460</b>	<b>376 736</b>	<b>131 722 096,08</b>	<b>63 009</b>	<b>970 958</b>	<b>0,388</b>	<b>167,20</b>	<b>13,933</b>	<b>03/07/2029</b>
41,10	2466	373 929	132 096 025,08	62 555	970 958	0,385	167,59	13,966	15/07/2029
41,20	2472	371 085	132 467 110,08	62 085	970 958	0,382	167,97	13,997	27/07/2029
41,30	2478	368 234	132 835 344,08	61 610	970 958	0,379	168,35	14,029	07/08/2029
41,40	2484	365 347	133 200 691,08	61 132	970 958	0,376	168,72	14,060	19/08/2029
41,50	2490	362 392	133 563 083,08	60 645	970 958	0,373	169,10	14,091	30/08/2029
41,60	2496	359 330	133 922 413,08	60 144	970 958	0,370	169,47	14,122	10/09/2029
41,70	2502	356 115	134 278 528,08	59 620	970 958	0,367	169,83	14,153	21/09/2029



# Jones & Wagener

Engineering & Environmental Consultants

59 Bevan Road PO Box 1434 Rivonia 2128 South Africa  
 tel: 0027 11 519 0200 www.jaws.co.za email: post@jaws.co.za

Client:  
Job Des.

Eskom  
 Conceptual Modelling for Medupi Power station  
 Northern Ash Dump Facility

Job No:  
Sheet No:  
Made by:  
Date:

G145/00  
1  
SL  
23/11/2017

41,80	2508	352 780	134 631 308,08	59 075	970 958	0,363	170,20	14,183	02/10/2029
41,90	2514	349 412	134 980 720,08	58 516	970 958	0,360	170,56	14,213	13/10/2029
<b>42,00</b>	<b>2520</b>	<b>346 049</b>	<b>135 326 769,08</b>	<b>57 955</b>	<b>970 958</b>	<b>0,356</b>	<b>170,91</b>	<b>14,243</b>	<b>24/10/2029</b>
42,10	2 526	342 877	135 669 646,08	57 411	970 958	0,353	171,27	14,272	04/11/2029
42,20	2532	340 094	136 009 740,08	56 914	970 958	0,350	171,62	14,301	15/11/2029
42,30	2538	337 577	136 347 317,08	56 473	970 958	0,348	171,96	14,330	25/11/2029
42,40	2544	335 104	136 682 421,08	56 057	970 958	0,345	172,31	14,359	06/12/2029
42,50	2550	332 644	137 015 065,08	55 646	970 958	0,343	172,65	14,388	16/12/2029
42,60	2556	330 263	137 345 328,08	55 242	970 958	0,340	172,99	14,416	26/12/2029
42,70	2562	328 008	137 673 336,08	54 856	970 958	0,338	173,33	14,444	06/01/2030
42,80	2568	325 818	137 999 154,08	54 486	970 958	0,336	173,67	14,472	16/01/2030
42,90	2574	323 643	138 322 797,08	54 122	970 958	0,333	174,00	14,500	26/01/2030
<b>43,00</b>	<b>2580</b>	<b>321 506</b>	<b>138 644 303,08</b>	<b>53 762</b>	<b>970 958</b>	<b>0,331</b>	<b>174,33</b>	<b>14,528</b>	<b>05/02/2030</b>
43,10	2586	319 509	138 963 812,08	53 418	970 958	0,329	174,66	14,555	15/02/2030
43,20	2592	317 685	139 281 497,08	53 100	970 958	0,327	174,99	14,582	25/02/2030
43,30	2598	315 941	139 597 438,08	52 802	970 958	0,325	175,31	14,609	07/03/2030
43,40	2604	314 265	139 911 703,08	52 517	970 958	0,324	175,64	14,636	17/03/2030
43,50	2610	312 757	140 224 460,08	52 252	970 958	0,322	175,96	14,663	27/03/2030
43,60	2616	311 465	140 535 925,08	52 019	970 958	0,321	176,28	14,690	05/04/2030
43,70	2622	310 284	140 846 209,08	51 812	970 958	0,320	176,60	14,716	15/04/2030
43,80	2628	309 076	141 155 285,08	51 613	970 958	0,318	176,92	14,743	25/04/2030
43,90	2634	307 842	141 463 127,08	51 410	970 958	0,317	177,23	14,769	04/05/2030
<b>44,00</b>	<b>2640</b>	<b>306 678</b>	<b>141 769 805,08</b>	<b>51 210</b>	<b>970 958</b>	<b>0,316</b>	<b>177,55</b>	<b>14,796</b>	<b>14/05/2030</b>
44,10	2646	305 627	142 075 432,08	51 025	970 958	0,315	177,86	14,822	24/05/2030
44,20	2652	304 684	142 380 116,08	50 859	970 958	0,314	178,18	14,848	02/06/2030
44,30	2658	303 867	142 683 983,08	50 713	970 958	0,313	178,49	14,874	12/06/2030
44,40	2664	303 200	142 987 183,08	50 589	970 958	0,312	178,80	14,900	21/06/2030
44,50	2670	302 663	143 289 846,08	50 489	970 958	0,312	179,11	14,926	01/07/2030
44,60	2676	302 221	143 592 067,08	50 407	970 958	0,311	179,43	14,952	10/07/2030
44,70	2682	301 874	143 893 941,08	50 341	970 958	0,311	179,74	14,978	19/07/2030
44,80	2688	301 633	144 195 574,08	50 292	970 958	0,311	180,05	15,004	29/07/2030
44,90	2694	301 521	144 497 095,08	50 263	970 958	0,311	180,36	15,030	07/08/2030
<b>45,00</b>	<b>2700</b>	<b>301 531</b>	<b>144 798 626,08</b>	<b>50 254</b>	<b>970 958</b>	<b>0,311</b>	<b>180,67</b>	<b>15,056</b>	<b>17/08/2030</b>
45,10	2706	301 587	145 100 213,08	50 260	970 958	0,311	180,98	15,082	26/08/2030
45,20	2712	301 595	145 401 808,08	50 265	970 958	0,311	181,29	15,107	05/09/2030
45,30	2718	301 525	145 703 333,08	50 260	970 958	0,311	181,60	15,133	14/09/2030
45,40	2724	301 399	146 004 732,08	50 244	970 958	0,310	181,91	15,159	24/09/2030
45,50	2730	301 266	146 305 998,08	50 222	970 958	0,310	182,22	15,185	03/10/2030
45,60	2736	301 154	146 607 152,08	50 202	970 958	0,310	182,53	15,211	12/10/2030
45,70	2742	301 092	146 908 244,08	50 187	970 958	0,310	182,84	15,237	22/10/2030
45,80	2748	301 130	147 209 374,08	50 185	970 958	0,310	183,15	15,263	31/10/2030
45,90	2754	301 304	147 510 678,08	50 203	970 958	0,310	183,46	15,288	10/11/2030
<b>46,00</b>	<b>2760</b>	<b>301 592</b>	<b>147 812 270,08</b>	<b>50 241</b>	<b>970 958</b>	<b>0,311</b>	<b>183,77</b>	<b>15,314</b>	<b>19/11/2030</b>
46,10	2766	301 937	148 114 207,08	50 294	970 958	0,311	184,08	15,340	29/11/2030
46,20	2772	302 255	148 416 462,08	50 349	970 958	0,311	184,39	15,366	08/12/2030
46,30	2778	302 456	148 718 918,08	50 393	970 958	0,312	184,71	15,392	18/12/2030
46,40	2784	302 504	149 021 422,08	50 413	970 958	0,312	185,02	15,418	27/12/2030
46,50	2790	302 424	149 323 846,08	50 411	970 958	0,311	185,33	15,444	06/01/2031
46,60	2796	302 304	149 626 150,08	50 394	970 958	0,311	185,64	15,470	15/01/2031
46,70	2802	302 250	149 928 400,08	50 380	970 958	0,311	185,95	15,496	25/01/2031
46,80	2808	302 255	150 230 655,08	50 375	970 958	0,311	186,26	15,522	03/02/2031
46,90	2814	302 252	150 532 907,08	50 376	970 958	0,311	186,57	15,548	12/02/2031
<b>47,00</b>	<b>2820</b>	<b>302 240</b>	<b>150 835 147,08</b>	<b>50 374</b>	<b>970 958</b>	<b>0,311</b>	<b>186,89</b>	<b>15,574</b>	<b>22/02/2031</b>



# Jones & Wagener

Engineering & Environmental Consultants

59 Bevan Road PO Box 1434 Rivonia 2128 South Africa  
tel:0027 11 519 0200 www.jaws.co.za email:post@jaws.co.za

Client:  
Job Des.

Eskom  
Conceptual Modelling for Medupi Power station  
Northern Ash Dump Facility

Job No:  
Sheet No:  
Made by:  
Date:

G145/00  
1  
SL  
23/11/2017

47,10	2826	302 242	151 137 389,08	50 374	970 958	0,311	187,20	15,600	03/03/2031
47,20	2832	302 265	151 439 654,08	50 376	970 958	0,311	187,51	15,626	13/03/2031
47,30	2838	302 290	151 741 944,08	50 380	970 958	0,311	187,82	15,652	22/03/2031
47,40	2844	302 294	152 044 238,08	50 382	970 958	0,311	188,13	15,678	01/04/2031
47,50	2850	302 282	152 346 520,08	50 381	970 958	0,311	188,44	15,704	10/04/2031
47,60	2856	302 273	152 648 793,08	50 380	970 958	0,311	188,75	15,729	20/04/2031
47,70	2862	302 273	152 951 066,08	50 379	970 958	0,311	189,06	15,755	29/04/2031
47,80	2868	302 279	153 253 345,08	50 379	970 958	0,311	189,38	15,781	09/05/2031
47,90	2874	302 259	153 555 604,08	50 378	970 958	0,311	189,69	15,807	18/05/2031
<b>48,00</b>	<b>2880</b>	<b>302 198</b>	<b>153 857 802,08</b>	<b>50 371</b>	<b>970 958</b>	<b>0,311</b>	<b>190,00</b>	<b>15,833</b>	<b>28/05/2031</b>
48,10	2886	302 111	154 159 913,08	50 359	970 958	0,311	190,31	15,859	06/06/2031
48,20	2892	302 044	154 461 957,08	50 346	970 958	0,311	190,62	15,885	16/06/2031
48,30	2 898	301 971	154 763 928,08	50 335	970 958	0,311	190,93	15,911	25/06/2031
48,40	2904	301 866	155 065 794,08	50 320	970 958	0,311	191,24	15,937	04/07/2031
48,50	2910	301 748	155 367 542,08	50 301	970 958	0,311	191,55	15,963	14/07/2031
48,60	2916	301 652	155 669 194,08	50 283	970 958	0,311	191,86	15,989	23/07/2031
48,70	2922	301 597	155 970 791,08	50 271	970 958	0,311	192,17	16,015	02/08/2031
48,80	2928	301 578	156 272 369,08	50 265	970 958	0,311	192,49	16,040	11/08/2031
48,90	2934	301 585	156 573 954,08	50 264	970 958	0,311	192,80	16,066	21/08/2031
<b>49,00</b>	<b>2940</b>	<b>301 582</b>	<b>156 875 536,08</b>	<b>50 264</b>	<b>970 958</b>	<b>0,311</b>	<b>193,11</b>	<b>16,092</b>	<b>30/08/2031</b>
49,10	2946	301 528	157 177 064,08	50 259	970 958	0,311	193,42	16,118	09/09/2031
49,20	2952	301 437	157 478 501,08	50 247	970 958	0,310	193,73	16,144	18/09/2031
49,30	2958	301 385	157 779 886,08	50 235	970 958	0,310	194,04	16,170	27/09/2031
49,40	2964	301 396	158 081 282,08	50 232	970 958	0,310	194,35	16,196	07/10/2031
49,50	2970	301 443	158 382 725,08	50 237	970 958	0,310	194,66	16,222	16/10/2031
49,60	2976	301 525	158 684 250,08	50 247	970 958	0,311	194,97	16,247	26/10/2031
49,70	2982	301 670	158 985 920,08	50 266	970 958	0,311	195,28	16,273	04/11/2031
49,80	2988	301 825	159 287 745,08	50 291	970 958	0,311	195,59	16,299	14/11/2031
49,90	2994	301 893	159 589 638,08	50 310	970 958	0,311	195,90	16,325	23/11/2031
<b>50,00</b>	<b>3000</b>	<b>301 878</b>	<b>159 891 516,08</b>	<b>50 314</b>	<b>970 958</b>	<b>0,311</b>	<b>196,21</b>	<b>16,351</b>	<b>03/12/2031</b>
50,10	3006	301 853	160 193 369,08	50 311	970 958	0,311	196,52	16,377	12/12/2031
50,20	3012	301 873	160 495 242,08	50 311	970 958	0,311	196,83	16,403	22/12/2031
50,30	3018	301 938	160 797 180,08	50 318	970 958	0,311	197,15	16,429	31/12/2031
50,40	3024	302 021	161 099 201,08	50 330	970 958	0,311	197,46	16,455	09/01/2032
50,50	3030	302 113	161 401 314,08	50 345	970 958	0,311	197,77	16,481	19/01/2032
50,60	3036	302 271	161 703 585,08	50 365	970 958	0,311	198,08	16,507	28/01/2032
50,70	3042	302 538	162 006 123,08	50 401	970 958	0,312	198,39	16,533	07/02/2032
50,80	3048	302 839	162 308 962,08	50 448	970 958	0,312	198,70	16,559	16/02/2032
50,90	3054	303 053	162 612 015,08	50 491	970 958	0,312	199,01	16,585	26/02/2032
<b>51,00</b>	<b>3060</b>	<b>303 167</b>	<b>162 915 182,08</b>	<b>50 518</b>	<b>970 958</b>	<b>0,312</b>	<b>199,33</b>	<b>16,611</b>	<b>06/03/2032</b>
51,10	3066	303 246	163 218 428,08	50 534	970 958	0,312	199,64	16,637	16/03/2032
51,20	3 072	303 320	163 521 748,08	50 547	970 958	0,312	199,95	16,663	25/03/2032
51,30	3078	303 403	163 825 151,08	50 560	970 958	0,312	200,26	16,689	04/04/2032
51,40	3084	303 539	164 128 690,08	50 579	970 958	0,313	200,58	16,715	13/04/2032
51,50	3090	303 754	164 432 444,08	50 608	970 958	0,313	200,89	16,741	23/04/2032
51,60	3096	304 014	164 736 458,08	50 647	970 958	0,313	201,20	16,767	02/05/2032
51,70	3102	304 250	165 040 708,08	50 689	970 958	0,313	201,52	16,793	12/05/2032
51,80	3108	304 466	165 345 174,08	50 726	970 958	0,314	201,83	16,819	21/05/2032
51,90	3114	304 691	165 649 865,08	50 763	970 958	0,314	202,14	16,845	31/05/2032
<b>52,00</b>	<b>3120</b>	<b>304 909</b>	<b>165 954 774,08</b>	<b>50 800</b>	<b>970 958</b>	<b>0,314</b>	<b>202,46</b>	<b>16,871</b>	<b>10/06/2032</b>
52,10	3126	305 097	166 259 871,08	50 834	970 958	0,314	202,77	16,898	19/06/2032
52,20	3132	305 261	166 565 132,08	50 863	970 958	0,314	203,09	16,924	29/06/2032
52,30	3138	305 403	166 870 535,08	50 889	970 958	0,315	203,40	16,950	08/07/2032



# Jones & Wagener

Engineering & Environmental Consultants

59 Bevan Road PO Box 1434 Rivonia 2128 South Africa  
 tel: 0027 11 519 0200 www.jaws.co.za email: post@jaws.co.za

Client:  
 Job Des.

Eskom  
 Conceptual Modelling for Medupi Power station  
 Northern Ash Dump Facility

Job No:  
 Sheet No:  
 Made by:  
 Date:

G145/00  
 1  
 SL  
 23/11/2017

52,40	3144	305 508	167 176 043,08	50 909	970 958	0,315	203,72	16,976	18/07/2032
52,50	3150	305 574	167 481 617,08	50 924	970 958	0,315	204,03	17,003	27/07/2032
52,60	3156	305 640	167 787 257,08	50 935	970 958	0,315	204,34	17,029	06/08/2032
52,70	3162	305 767	168 093 024,08	50 951	970 958	0,315	204,66	17,055	16/08/2032
52,80	3168	305 945	168 398 969,08	50 976	970 958	0,315	204,97	17,081	25/08/2032
52,90	3174	306 113	168 705 082,08	51 005	970 958	0,315	205,29	17,108	04/09/2032
<b>53,00</b>	<b>3180</b>	<b>306 241</b>	<b>169 011 323,08</b>	<b>51 030</b>	<b>970 958</b>	<b>0,315</b>	<b>205,61</b>	<b>17,134</b>	<b>13/09/2032</b>
53,10	3186	306 363	169 317 686,08	51 050	970 958	0,316	205,92	17,160	23/09/2032
53,20	3192	306 539	169 624 225,08	51 075	970 958	0,316	206,24	17,186	03/10/2032
53,30	3198	306 788	169 931 013,08	51 111	970 958	0,316	206,55	17,213	12/10/2032
53,40	3204	307 070	170 238 083,08	51 155	970 958	0,316	206,87	17,239	22/10/2032
53,50	3210	307 369	170 545 452,08	51 203	970 958	0,317	207,19	17,265	31/10/2032
53,60	3216	307 688	170 853 140,08	51 255	970 958	0,317	207,50	17,292	10/11/2032
53,70	3222	307 989	171 161 129,08	51 306	970 958	0,317	207,82	17,318	20/11/2032
53,80	3228	308 276	171 469 405,08	51 355	970 958	0,317	208,14	17,345	29/11/2032
53,90	3234	308 585	171 777 990,08	51 405	970 958	0,318	208,45	17,371	09/12/2032
<b>54,00</b>	<b>3240</b>	<b>308 912</b>	<b>172 086 902,08</b>	<b>51 458</b>	<b>970 958</b>	<b>0,318</b>	<b>208,77</b>	<b>17,398</b>	<b>19/12/2032</b>
54,10	3246	309 201	172 396 103,08	51 509	970 958	0,318	209,09	17,424	28/12/2032
54,20	3252	309 391	172 705 494,08	51 549	970 958	0,319	209,41	17,451	07/01/2033
54,30	3258	309 502	173 014 996,08	51 574	970 958	0,319	209,73	17,477	17/01/2033
54,40	3264	309 611	173 324 607,08	51 593	970 958	0,319	210,05	17,504	26/01/2033
54,50	3270	309 771	173 634 378,08	51 615	970 958	0,319	210,37	17,531	05/02/2033
54,60	3276	309 938	173 944 316,08	51 642	970 958	0,319	210,69	17,557	15/02/2033
54,70	3282	310 031	174 254 347,08	51 664	970 958	0,319	211,01	17,584	25/02/2033
54,80	3288	310 048	174 564 395,08	51 673	970 958	0,319	211,32	17,610	06/03/2033
54,90	3294	310 059	174 874 454,08	51 676	970 958	0,319	211,64	17,637	16/03/2033
<b>55,00</b>	<b>3300</b>	<b>310 127</b>	<b>175 184 581,08</b>	<b>51 682</b>	<b>970 958</b>	<b>0,319</b>	<b>211,96</b>	<b>17,664</b>	<b>26/03/2033</b>
55,10	3306	310 224	175 494 805,08	51 696	970 958	0,320	212,28	17,690	04/04/2033
55,20	3312	310 270	175 805 075,08	51 708	970 958	0,320	212,60	17,717	14/04/2033
55,30	3318	310 271	176 115 346,08	51 712	970 958	0,320	212,92	17,744	24/04/2033
55,40	3324	310 305	176 425 651,08	51 715	970 958	0,320	213,24	17,770	04/05/2033
55,50	3330	310 435	176 736 086,08	51 728	970 958	0,320	213,56	17,797	13/05/2033
55,60	3336	310 640	177 046 726,08	51 756	970 958	0,320	213,88	17,823	23/05/2033
55,70	3342	310 842	177 357 568,08	51 790	970 958	0,320	214,20	17,850	02/06/2033
55,80	3348	310 951	177 668 519,08	51 816	970 958	0,320	214,52	17,877	12/06/2033
55,90	3354	310 927	177 979 446,08	51 823	970 958	0,320	214,84	17,903	21/06/2033
<b>56,00</b>	<b>3360</b>	<b>310 844</b>	<b>178 290 290,08</b>	<b>51 814</b>	<b>970 958</b>	<b>0,320</b>	<b>215,16</b>	<b>17,930</b>	<b>01/07/2033</b>
56,10	3366	310 823	178 601 113,08	51 806	970 958	0,320	215,48	17,957	11/07/2033
56,20	3372	310 927	178 912 040,08	51 813	970 958	0,320	215,80	17,984	20/07/2033
56,30	3378	311 096	179 223 136,08	51 835	970 958	0,320	216,12	18,010	30/07/2033
56,40	3384	311 257	179 534 393,08	51 863	970 958	0,321	216,44	18,037	09/08/2033
56,50	3390	311 364	179 845 757,08	51 885	970 958	0,321	216,76	18,064	19/08/2033
56,60	3396	311 406	180 157 163,08	51 898	970 958	0,321	217,08	18,090	28/08/2033
56,70	3402	311 389	180 468 552,08	51 900	970 958	0,321	217,41	18,117	07/09/2033
56,80	3408	311 377	180 779 929,08	51 897	970 958	0,321	217,73	18,144	17/09/2033
56,90	3414	311 454	181 091 383,08	51 903	970 958	0,321	218,05	18,171	27/09/2033
<b>57,00</b>	<b>3420</b>	<b>311 606</b>	<b>181 402 989,08</b>	<b>51 922</b>	<b>970 958</b>	<b>0,321</b>	<b>218,37</b>	<b>18,197</b>	<b>07/10/2033</b>
57,10	3426	311 732	181 714 721,08	51 945	970 958	0,321	218,69	18,224	16/10/2033
57,20	3 432	311 791	182 026 512,08	51 960	970 958	0,321	219,01	18,251	26/10/2033
57,30	3438	311 805	182 338 317,08	51 966	970 958	0,321	219,33	18,278	05/11/2033
57,40	3444	310 848	182 649 165,08	51 888	970 958	0,320	219,65	18,304	15/11/2033
57,50	3450	308 862	182 958 027,08	51 643	970 958	0,318	219,97	18,331	24/11/2033
57,60	3456	306 745	183 264 772,08	51 301	970 958	0,316	220,29	18,357	04/12/2033



# Jones & Wagener

Engineering & Environmental Consultants

59 Bevan Road PO Box 1434 Rivonia 2128 South Africa  
 tel: 0027 11 519 0200 www.jaws.co.za email: post@jaws.co.za

Client:  
 Job Des.

Eskom  
 Conceptual Modelling for Medupi Power station  
 Northern Ash Dump Facility

Job No:  
 Sheet No:  
 Made by:  
 Date:

G145/00  
 1  
 SL  
 23/11/2017

57,70	3462	304 569	183 569 341,08	50 943	970 958	0,314	220,60	18,383	13/12/2033
57,80	3468	302 373	183 871 714,08	50 579	970 958	0,311	220,91	18,409	23/12/2033
57,90	3474	300 135	184 171 849,08	50 209	970 958	0,309	221,22	18,435	01/01/2034
<b>58,00</b>	<b>3480</b>	<b>297 790</b>	<b>184 469 639,08</b>	<b>49 827</b>	<b>970 958</b>	<b>0,307</b>	<b>221,53</b>	<b>18,461</b>	<b>11/01/2034</b>
58,10	3486	295 319	184 764 958,08	49 426	970 958	0,304	221,83	18,486	20/01/2034
58,20	3492	292 738	185 057 696,08	49 005	970 958	0,301	222,13	18,511	29/01/2034
58,30	3498	290 047	185 347 743,08	48 565	970 958	0,299	222,43	18,536	07/02/2034
58,40	3504	286 712	185 634 455,08	48 063	970 958	0,295	222,73	18,560	16/02/2034
58,50	3510	282 756	185 917 211,08	47 456	970 958	0,291	223,02	18,585	25/02/2034
58,60	3516	278 734	186 195 945,08	46 791	970 958	0,287	223,30	18,609	06/03/2034
58,70	3522	274 646	186 470 591,08	46 115	970 958	0,283	223,59	18,632	14/03/2034
58,80	3528	270 474	186 741 065,08	45 427	970 958	0,279	223,87	18,655	23/03/2034
58,90	3534	266 208	187 007 273,08	44 724	970 958	0,274	224,14	18,678	31/03/2034
<b>59,00</b>	<b>3540</b>	<b>261 832</b>	<b>187 269 105,08</b>	<b>44 003</b>	<b>970 958</b>	<b>0,270</b>	<b>224,41</b>	<b>18,701</b>	<b>08/04/2034</b>
	3546	257 353	187 526 458,08	43 265	970 958	0,265	224,67	18,723	16/04/2034
	3552	252 826	187 779 284,08	42 515	970 958	0,260	224,93	18,745	24/04/2034
	3558	248 243	188 027 527,08	41 756	970 958	0,256	225,19	18,766	02/05/2034
	3564	243 516	188 271 043,08	40 980	970 958	0,251	225,44	18,787	10/05/2034
	3570	238 650	188 509 693,08	40 181	970 958	0,246	225,69	18,807	17/05/2034
	3576	233 729	188 743 422,08	39 365	970 958	0,241	225,93	18,827	24/05/2034
	3582	228 786	188 972 208,08	38 543	970 958	0,236	226,16	18,847	01/06/2034
	3588	223 795	189 196 003,08	37 715	970 958	0,230	226,39	18,866	08/06/2034
	3594	218 739	189 414 742,08	36 878	970 958	0,225	226,62	18,885	15/06/2034
	3600	213 597	189 628 339,08	36 028	970 958	0,220	226,84	18,903	21/06/2034
	3606	208 350	189 836 689,08	35 162	970 958	0,215	227,05	18,921	28/06/2034
	3612	202 983	190 039 672,08	34 278	970 958	0,209	227,26	18,939	04/07/2034
	3618	197 535	190 237 207,08	33 377	970 958	0,203	227,47	18,956	10/07/2034
	3624	192 066	190 429 273,08	32 467	970 958	0,198	227,66	18,972	16/07/2034
	3630	186 548	190 615 821,08	31 551	970 958	0,192	227,86	18,988	22/07/2034
	3636	180 951	190 796 772,08	30 625	970 958	0,186	228,04	19,004	28/07/2034
	3642	175 260	190 972 032,08	29 684	970 958	0,181	228,22	19,019	02/08/2034
	3648	169 445	191 141 477,08	28 725	970 958	0,175	228,40	19,033	08/08/2034
	3654	163 509	191 304 986,08	27 746	970 958	0,168	228,57	19,047	13/08/2034
	3660	157 509	191 462 495,08	26 752	970 958	0,162	228,73	19,061	18/08/2034
	3666	151 536	191 614 031,08	25 754	970 958	0,156	228,88	19,074	22/08/2034
	3672	145 633	191 759 664,08	24 764	970 958	0,150	229,03	19,086	27/08/2034
	3678	139 747	191 899 411,08	23 782	970 958	0,144	229,18	19,098	31/08/2034
	3684	133 761	192 033 172,08	22 792	970 958	0,138	229,32	19,110	05/09/2034
	3690	127 584	192 160 756,08	21 779	970 958	0,131	229,45	19,121	09/09/2034
	3696	121 234	192 281 990,08	20 735	970 958	0,125	229,57	19,131	12/09/2034
	3702	114 731	192 396 721,08	19 664	970 958	0,118	229,69	19,141	16/09/2034
	3708	108 110	192 504 831,08	18 570	970 958	0,111	229,80	19,150	19/09/2034
	3714	101 456	192 606 287,08	17 464	970 958	0,104	229,91	19,159	22/09/2034
	3720	94 822	192 701 109,08	16 357	970 958	0,098	230,00	19,167	25/09/2034
	3726	88 189	192 789 298,08	15 251	970 958	0,091	230,09	19,175	28/09/2034
	3732	81 488	192 870 786,08	14 140	970 958	0,084	230,18	19,182	01/10/2034
	3738	74 646	192 945 432,08	13 011	970 958	0,077	230,26	19,188	03/10/2034
	3744	67 674	193 013 106,08	11 860	970 958	0,070	230,33	19,194	05/10/2034
	3750	60 616	193 073 722,08	10 691	970 958	0,062	230,39	19,199	07/10/2034
	3756	53 477	193 127 199,08	9 508	970 958	0,055	230,44	19,204	09/10/2034
	3762	46 242	193 173 441,08	8 310	970 958	0,048	230,49	19,208	10/10/2034
	3768	38 947	193 212 388,08	7 099	970 958	0,040	230,53	19,211	11/10/2034
	3774	31 853	193 244 241,08	5 900	970 958	0,033	230,56	19,214	12/10/2034



# Jones & Wagener

Engineering & Environmental Consultants

59 Bevan Road PO Box 1434 Rivonia 2128 South Africa  
 tel:0027 11 519 0200 www.jaws.co.za email:post@jaws.co.za

Client:  
Job Des.

Eskom  
 Conceptual Modelling for Medupi Power station  
 Northern Ash Dump Facility

Job No:  
Sheet No:  
Made by:  
Date:

G145/00  
1  
SL  
23/11/2017

3780	25 149	193 269 390,08	4 750	970 958	0,026	230,59	19,216	13/10/2034
3786	18 858	193 288 248,08	3 667	970 958	0,019	230,61	19,217	14/10/2034
3792	13 169	193 301 417,08	2 669	970 958	0,014	230,62	19,219	14/10/2034
3798	8 247	193 309 664	1 785	970 958	0,008	230,63	19,219	15/10/2034
3804	4 216	193 313 880,08	1 039	970 958	0,004	230,63	19,220	15/10/2034
3810	1 225	193 315 105,08	453	970 958	0,001	230,64	19,220	15/10/2034

## Northern stacker

										Volume per shift
35,90	2154		53918990,24							
<b>36,00</b>	<b>2160</b>	<b>402 120</b>	<b>54 321 110,24</b>	<b>601 994</b>	<b>0,668</b>	<b>146,21</b>	<b>12,184</b>	<b>04/10/2027</b>		
36,10	2166	201 462	54 522 572,24	50 299	601 994	0,335	146,54	12,212	14/10/2027	
36,20	2172	201 662	54 724 234,24	33 594	601 994	0,335	146,88	12,240	27/10/2027	
36,30	2178	201 770	54 926 004,24	33 619	601 994	0,335	147,21	12,268	06/11/2027	
36,40	2184	201 859	55 127 863,24	33 636	601 994	0,335	147,55	12,296	16/11/2027	
36,50	2190	201 989	55 329 852,24	33 654	601 994	0,336	147,88	12,324	26/11/2027	
36,60	2196	202 150	55 532 002,24	33 678	601 994	0,336	148,22	12,352	07/12/2027	
36,70	2202	202 323	55 734 325,24	33 706	601 994	0,336	148,56	12,380	17/12/2027	
36,80	2208	202 484	55 936 809,24	33 734	601 994	0,336	148,89	12,408	27/12/2027	
36,90	2214	202 616	56 139 425,24	33 758	601 994	0,337	149,23	12,436	06/01/2028	
<b>37,00</b>	<b>2220</b>	<b>202 742</b>	<b>56 342 167,24</b>	<b>33 780</b>	<b>601 994</b>	<b>0,337</b>	<b>149,57</b>	<b>17/01/2028</b>	<b>2021057</b>	
37,10	2226	202 915	56 545 082,24	33 805	601 994	0,337	149,90	12,492	27/01/2028	
37,20	2232	203 148	56 748 230,24	33 839	601 994	0,337	150,24	12,520	06/02/2028	
37,30	2238	203 381	56 951 611,24	33 877	601 994	0,338	150,58	12,548	16/02/2028	
37,40	2244	203 523	57 155 134,24	33 909	601 994	0,338	150,92	12,576	27/02/2028	
37,50	2250	203 560	57 358 694,24	33 924	601 994	0,338	151,25	12,605	08/03/2028	
37,60	2256	203 567	57 562 261,24	33 927	601 994	0,338	151,59	12,633	18/03/2028	
37,70	2262	203 601	57 765 862,24	33 931	601 994	0,338	151,93	12,661	29/03/2028	
37,80	2268	203 651	57 969 513,24	33 938	601 994	0,338	152,27	12,689	08/04/2028	
37,90	2274	203 697	58 173 210,24	33 946	601 994	0,338	152,61	12,717	18/04/2028	
<b>38,00</b>	<b>2280</b>	<b>203 762</b>	<b>58 376 972,24</b>	<b>33 955</b>	<b>601 994</b>	<b>0,338</b>	<b>152,95</b>	<b>28/04/2028</b>	<b>2034805</b>	
38,10	2286	203 902	58 580 874,24	33 972	601 994	0,339	153,28	12,774	09/05/2028	
38,20	2292	204 114	58 784 988,24	34 001	601 994	0,339	153,62	12,802	19/05/2028	
38,30	2298	204 352	58 989 340,24	34 039	601 994	0,339	153,96	12,830	29/05/2028	
38,40	2304	204 559	59 193 899,24	34 076	601 994	0,340	154,30	12,859	09/06/2028	
38,50	2310	204 755	59 398 654,24	34 110	601 994	0,340	154,64	12,887	19/06/2028	
38,60	2316	204 930	59 603 584,24	34 140	601 994	0,340	154,98	12,915	29/06/2028	
38,70	2322	205 037	59 808 621,24	34 164	601 994	0,341	155,32	12,944	10/07/2028	
38,80	2328	205 055	60 013 676,24	34 174	601 994	0,341	155,66	12,972	20/07/2028	
38,90	2334	205 047	60 218 723,24	34 175	601 994	0,341	156,01	13,000	30/07/2028	
<b>39,00</b>	<b>2340</b>	<b>205 085</b>	<b>60 423 808,24</b>	<b>34 178</b>	<b>601 994</b>	<b>0,341</b>	<b>156,35</b>	<b>13,029</b>	<b>10/08/2028</b>	<b>2046836</b>
39,10	2 346	205 181	60 628 989,24	34 189	601 994	0,341	156,69	13,057	20/08/2028	
39,20	2352	205 353	60 834 342,24	34 211	601 994	0,341	157,03	13,086	31/08/2028	
39,30	2358	205 569	61 039 911,24	34 244	601 994	0,341	157,37	13,114	10/09/2028	
39,40	2364	205 791	61 245 702,24	34 280	601 994	0,342	157,71	13,143	20/09/2028	
39,50	2370	205 958	61 451 660,24	34 312	601 994	0,342	158,05	13,171	01/10/2028	
39,60	2376	206 059	61 657 719,24	34 335	601 994	0,342	158,40	13,200	11/10/2028	
39,70	2382	206 141	61 863 860,24	34 350	601 994	0,342	158,74	13,228	22/10/2028	
39,80	2388	206 261	62 070 121,24	34 367	601 994	0,343	159,08	13,257	01/11/2028	
39,90	2394	206 421	62 276 542,24	34 390	601 994	0,343	159,42	13,285	11/11/2028	
<b>40,00</b>	<b>2400</b>	<b>206 558</b>	<b>62 483 100,24</b>	<b>34 415</b>	<b>601 994</b>	<b>0,343</b>	<b>159,77</b>	<b>13,314</b>	<b>22/11/2028</b>	<b>2059292</b>



# Jones & Wagener

Engineering & Environmental Consultants

59 Bevan Road PO Box 1434 Rivonia 2128 South Africa  
 tel: 0027 11 519 0200 www.jaws.co.za email: post@jaws.co.za

Client:  
 Job Des.

Eskom  
 Conceptual Modelling for Medupi Power station  
 Northern Ash Dump Facility

Job No:  
 Sheet No:  
 Made by:  
 Date:

G145/00  
 1  
 SL  
 23/11/2017

40,10	2406	206 591	62 689 691,24	34 429	601 994	0,343	160,11	13,342	02/12/2028	
40,20	2412	206 481	62 896 172,24	34 423	601 994	0,343	160,45	13,371	13/12/2028	
40,30	2418	206 275	63 102 447,24	34 396	601 994	0,343	160,80	13,400	23/12/2028	
40,40	2424	206 045	63 308 492,24	34 360	601 994	0,342	161,14	13,428	03/01/2029	
40,50	2430	205 846	63 514 338,24	34 324	601 994	0,342	161,48	13,457	13/01/2029	
40,60	2436	205 748	63 720 086,24	34 300	601 994	0,342	161,82	13,485	23/01/2029	
40,70	2442	205 778	63 925 864,24	34 294	601 994	0,342	162,16	13,514	03/02/2029	
40,80	2448	205 885	64 131 749,24	34 305	601 994	0,342	162,51	13,542	13/02/2029	
40,90	2454	205 962	64 337 711,24	34 321	601 994	0,342	162,85	13,571	24/02/2029	
<b>41,00</b>	<b>2460</b>	<b>205 935</b>	<b>64 543 646,24</b>	<b>34 325</b>	601 994	<b>0,342</b>	<b>163,19</b>	<b>13,599</b>	<b>06/03/2029</b>	<b>2060546</b>
41,10	2466	205 847	64 749 493,24	34 315	601 994	0,342	163,53	13,628	16/03/2029	
41,20	2472	205 779	64 955 272,24	34 302	601 994	0,342	163,87	13,656	27/03/2029	
41,30	2478	205 747	65 161 019,24	34 294	601 994	0,342	164,22	13,685	06/04/2029	
41,40	2484	205 751	65 366 770,24	34 292	601 994	0,342	164,56	13,713	17/04/2029	
41,50	2490	205 776	65 572 546,24	34 294	601 994	0,342	164,90	13,742	27/04/2029	
41,60	2496	205 778	65 778 324,24	34 296	601 994	0,342	165,24	13,770	07/05/2029	
41,70	2502	205 683	65 984 007,24	34 288	601 994	0,342	165,58	13,799	18/05/2029	
41,80	2508	205 494	66 189 501,24	34 265	601 994	0,341	165,92	13,827	28/05/2029	
41,90	2514	205 320	66 394 821,24	34 235	601 994	0,341	166,26	13,855	08/06/2029	
<b>42,00</b>	<b>2520</b>	<b>205 235</b>	<b>66 600 056,24</b>	<b>34 213</b>	601 994	<b>0,341</b>	<b>166,61</b>	<b>13,884</b>	<b>18/06/2029</b>	<b>2056410</b>
42,10	2526	205 269	66 805 325,24	34 209	601 994	0,341	166,95	13,912	28/06/2029	
42,20	2532	205 383	67 010 708,24	34 221	601 994	0,341	167,29	13,941	09/07/2029	
42,30	2538	205 484	67 216 192,24	34 239	601 994	0,341	167,63	13,969	19/07/2029	
42,40	2544	205 516	67 421 708,24	34 250	601 994	0,341	167,97	13,998	29/07/2029	
42,50	2550	205 512	67 627 220,24	34 252	601 994	0,341	168,31	14,026	09/08/2029	
42,60	2556	205 545	67 832 765,24	34 255	601 994	0,341	168,65	14,054	19/08/2029	
42,70	2562	205 639	68 038 404,24	34 265	601 994	0,342	168,99	14,083	30/08/2029	
42,80	2568	205 729	68 244 133,24	34 281	601 994	0,342	169,34	14,111	09/09/2029	
42,90	2574	205 756	68 449 889,24	34 290	601 994	0,342	169,68	14,140	19/09/2029	
<b>43,00</b>	<b>2580</b>	<b>205 726</b>	<b>68 655 615,24</b>	<b>34 290</b>	601 994	<b>0,342</b>	<b>170,02</b>	<b>14,168</b>	<b>30/09/2029</b>	<b>2055559</b>
43,10	2586	205 704	68 861 319,24	34 286	601 994	0,342	170,36	14,197	10/10/2029	
43,20	2592	205 743	69 067 062,24	34 287	601 994	0,342	170,70	14,225	21/10/2029	
43,30	2598	205 805	69 272 867,24	34 296	601 994	0,342	171,05	14,254	31/10/2029	
43,40	2604	205 885	69 478 752,24	34 308	601 994	0,342	171,39	14,282	10/11/2029	
43,50	2610	206 026	69 684 778,24	34 326	601 994	0,342	171,73	14,311	21/11/2029	
43,60	2616	206 223	69 891 001,24	34 354	601 994	0,343	172,07	14,339	01/12/2029	
43,70	2622	206 386	70 097 387,24	34 384	601 994	0,343	172,42	14,368	12/12/2029	
43,80	2628	206 436	70 303 823,24	34 402	601 994	0,343	172,76	14,397	22/12/2029	
43,90	2634	206 397	70 510 220,24	34 403	601 994	0,343	173,10	14,425	01/01/2030	
<b>44,00</b>	<b>2640</b>	<b>206 348</b>	<b>70 716 568,24</b>	<b>34 395</b>	601 994	<b>0,343</b>	<b>173,44</b>	<b>14,454</b>	<b>12/01/2030</b>	<b>2060953</b>
44,10	2646	206 326	70 922 894,24	34 390	601 994	0,343	173,79	14,482	22/01/2030	
44,20	2652	206 310	71 129 204,24	34 386	601 994	0,343	174,13	14,511	02/02/2030	
44,30	2658	206 289	71 335 493,24	34 383	601 994	0,343	174,47	14,539	12/02/2030	
44,40	2664	206 277	71 541 770,24	34 381	601 994	0,343	174,81	14,568	23/02/2030	
44,50	2670	206 258	71 748 028,24	34 378	601 994	0,343	175,16	14,596	05/03/2030	
44,60	2676	206 223	71 954 251,24	34 373	601 994	0,343	175,50	14,625	15/03/2030	
44,70	2682	206 178	72 160 429,24	34 367	601 994	0,342	175,84	14,654	26/03/2030	
44,80	2688	206 132	72 366 561,24	34 359	601 994	0,342	176,18	14,682	05/04/2030	
44,90	2694	206 103	72 572 664,24	34 353	601 994	0,342	176,53	14,711	16/04/2030	
<b>45,00</b>	<b>2700</b>	<b>206 139</b>	<b>72 778 803,24</b>	<b>34 354</b>	601 994	<b>0,342</b>	<b>176,87</b>	<b>14,739</b>	<b>26/04/2030</b>	<b>2062235</b>
45,10	2706	206 226	72 985 029,24	34 364	601 994	0,343	177,21	14,768	07/05/2030	
45,20	2712	206 289	73 191 318,24	34 376	601 994	0,343	177,55	14,796	17/05/2030	
45,30	2718	206 267	73 397 585,24	34 380	601 994	0,343	177,90	14,825	27/05/2030	





# Jones & Wagener

Engineering & Environmental Consultants

59 Bevan Road PO Box 1434 Rivonia 2128 South Africa  
 tel: 0027 11 519 0200 www.jaws.co.za email: post@jaws.co.za

Client:  
 Job Des.

Eskom  
 Conceptual Modelling for Medupi Power station  
 Northern Ash Dump Facility

Job No:  
 Sheet No:  
 Made by:  
 Date:

G145/00  
 1  
 SL  
 23/11/2017

45,40	2724	206 182	73 603 767,24	34 371	601 994	0,342	178,24	14,853	07/06/2030	
45,50	2730	206 090	73 809 857,24	34 356	601 994	0,342	178,58	14,882	17/06/2030	
45,60	2736	206 013	74 015 870,24	34 342	601 994	0,342	178,92	14,910	28/06/2030	
45,70	2742	205 979	74 221 849,24	34 333	601 994	0,342	179,27	14,939	08/07/2030	
45,80	2748	206 043	74 427 892,24	34 335	601 994	0,342	179,61	14,967	18/07/2030	
45,90	2754	206 238	74 634 130,24	34 357	601 994	0,343	179,95	14,996	29/07/2030	
<b>46,00</b>	<b>2760</b>	<b>206 524</b>	<b>74 840 654,24</b>	<b>34 397</b>	<b>601 994</b>	<b>0,343</b>	<b>180,29</b>	<b>15,025</b>	<b>08/08/2030</b>	<b>2061851</b>
46,10	2766	206 848	75 047 502,24	34 448	601 994	0,344	180,64	15,053	19/08/2030	
46,20	2772	207 128	75 254 630,24	34 498	601 994	0,344	180,98	15,082	29/08/2030	
46,30	2778	207 302	75 461 932,24	34 536	601 994	0,344	181,33	15,111	09/09/2030	
46,40	2784	207 353	75 669 285,24	34 555	601 994	0,344	181,67	15,139	19/09/2030	
46,50	2790	207 296	75 876 581,24	34 554	601 994	0,344	182,02	15,168	30/09/2030	
46,60	2796	207 189	76 083 770,24	34 540	601 994	0,344	182,36	15,197	10/10/2030	
46,70	2802	207 099	76 290 869,24	34 524	601 994	0,344	182,70	15,225	21/10/2030	
46,80	2808	207 010	76 497 879,24	34 509	601 994	0,344	183,05	15,254	31/10/2030	
46,90	2814	206 896	76 704 775,24	34 492	601 994	0,344	183,39	15,283	10/11/2030	
<b>47,00</b>	<b>2820</b>	<b>206 795</b>	<b>76 911 570,24</b>	<b>34 474</b>	<b>601 994</b>	<b>0,344</b>	<b>183,73</b>	<b>15,311</b>	<b>21/11/2030</b>	<b>2070916</b>
47,10	2826	206 730	77 118 300,24	34 460	601 994	0,343	184,08	15,340	01/12/2030	
47,20	2832	206 696	77 324 996,24	34 452	601 994	0,343	184,42	15,368	12/12/2030	
47,30	2838	206 695	77 531 691,24	34 449	601 994	0,343	184,76	15,397	22/12/2030	
47,40	2844	206 730	77 738 421,24	34 452	601 994	0,343	185,11	15,426	02/01/2031	
47,50	2850	206 789	77 945 210,24	34 460	601 994	0,344	185,45	15,454	12/01/2031	
47,60	2856	206 833	78 152 043,24	34 469	601 994	0,344	185,80	15,483	23/01/2031	
47,70	2862	206 838	78 358 881,24	34 473	601 994	0,344	186,14	15,512	02/02/2031	
47,80	2868	206 834	78 565 715,24	34 473	601 994	0,344	186,48	15,540	13/02/2031	
47,90	2874	206 823	78 772 538,24	34 471	601 994	0,344	186,83	15,569	23/02/2031	
<b>48,00</b>	<b>2880</b>	<b>206 777</b>	<b>78 979 315,24</b>	<b>34 467</b>	<b>601 994</b>	<b>0,343</b>	<b>187,17</b>	<b>15,597</b>	<b>05/03/2031</b>	<b>2067745</b>
48,10	2886	206 680	79 185 995,24	34 455	601 994	0,343	187,51	15,626	16/03/2031	
48,20	2892	206 573	79 392 568,24	34 438	601 994	0,343	187,86	15,655	26/03/2031	
48,30	2 898	206 470	79 599 038,24	34 420	601 994	0,343	188,20	15,683	06/04/2031	
48,40	2904	206 357	79 805 395,24	34 402	601 994	0,343	188,54	15,712	16/04/2031	
48,50	2910	206 233	80 011 628,24	34 383	601 994	0,343	188,88	15,740	27/04/2031	
48,60	2916	206 112	80 217 740,24	34 362	601 994	0,342	189,23	15,769	07/05/2031	
48,70	2922	206 034	80 423 774,24	34 346	601 994	0,342	189,57	15,797	17/05/2031	
48,80	2928	205 999	80 629 773,24	34 336	601 994	0,342	189,91	15,826	28/05/2031	
48,90	2934	205 986	80 835 759,24	34 332	601 994	0,342	190,25	15,854	07/06/2031	
<b>49,00</b>	<b>2940</b>	<b>205 953</b>	<b>81 041 712,24</b>	<b>34 328</b>	<b>601 994</b>	<b>0,342</b>	<b>190,60</b>	<b>15,883</b>	<b>18/06/2031</b>	<b>2062397</b>
49,10	2946	205 875	81 247 587,24	34 319	601 994	0,342	190,94	15,911	28/06/2031	
49,20	2952	205 781	81 453 368,24	34 305	601 994	0,342	191,28	15,940	08/07/2031	
49,30	2958	205 730	81 659 098,24	34 293	601 994	0,342	191,62	15,968	19/07/2031	
49,40	2964	205 714	81 864 812,24	34 287	601 994	0,342	191,96	15,997	29/07/2031	
49,50	2970	205 694	82 070 506,24	34 284	601 994	0,342	192,30	16,025	09/08/2031	
49,60	2976	205 686	82 276 192,24	34 282	601 994	0,342	192,65	16,054	19/08/2031	
49,70	2982	205 744	82 481 936,24	34 286	601 994	0,342	192,99	16,082	29/08/2031	
49,80	2988	205 837	82 687 773,24	34 298	601 994	0,342	193,33	16,111	09/09/2031	
49,90	2994	205 866	82 893 639,24	34 309	601 994	0,342	193,67	16,139	19/09/2031	
<b>50,00</b>	<b>3000</b>	<b>205 830</b>	<b>83 099 469,24</b>	<b>34 308</b>	<b>601 994</b>	<b>0,342</b>	<b>194,01</b>	<b>16,168</b>	<b>30/09/2031</b>	<b>2057757</b>
50,10	3006	205 806	83 305 275,24	34 303	601 994	0,342	194,36	16,196	10/10/2031	
50,20	3012	205 832	83 511 107,24	34 303	601 994	0,342	194,70	16,225	20/10/2031	
50,30	3018	205 902	83 717 009,24	34 311	601 994	0,342	195,04	16,253	31/10/2031	
50,40	3024	205 973	83 922 982,24	34 323	601 994	0,342	195,38	16,282	10/11/2031	
50,50	3030	206 016	84 128 998,24	34 332	601 994	0,342	195,72	16,310	21/11/2031	
50,60	3036	206 095	84 335 093,24	34 343	601 994	0,342	196,07	16,339	01/12/2031	



# Jones & Wagener

Engineering & Environmental Consultants

59 Bevan Road PO Box 1434 Rivonia 2128 South Africa  
 tel: 0027 11 519 0200 www.jaws.co.za email: post@jaws.co.za

Client:  
 Job Des.

Eskom  
 Conceptual Modelling for Medupi Power station  
 Northern Ash Dump Facility

Job No:  
 Sheet No:  
 Made by:  
 Date:

G145/00  
 1  
 SL  
 23/11/2017

50,70	3042	206 279	84 541 372,24	34 365	601 994	0,343	196,41	16,367	11/12/2031	
50,80	3048	206 515	84 747 887,24	34 400	601 994	0,343	196,75	16,396	22/12/2031	
50,90	3054	206 689	84 954 576,24	34 434	601 994	0,343	197,10	16,425	01/01/2032	
<b>51,00</b>	<b>3060</b>	<b>206 775</b>	<b>85 161 351,24</b>	<b>34 455</b>	<b>601 994</b>	<b>0,343</b>	<b>197,44</b>	<b>16,453</b>	<b>12/01/2032</b>	<b>2061882</b>
51,10	3066	206 832	85 368 183,24	34 467	601 994	0,344	197,78	16,482	22/01/2032	
51,20	3 072	206 892	85 575 075,24	34 477	601 994	0,344	198,13	16,510	02/02/2032	
51,30	3078	206 964	85 782 039,24	34 488	601 994	0,344	198,47	16,539	12/02/2032	
51,40	3084	207 068	85 989 107,24	34 503	601 994	0,344	198,81	16,568	23/02/2032	
51,50	3090	207 202	86 196 309,24	34 523	601 994	0,344	199,16	16,596	04/03/2032	
51,60	3096	207 332	86 403 641,24	34 545	601 994	0,344	199,50	16,625	15/03/2032	
51,70	3102	207 440	86 611 081,24	34 564	601 994	0,345	199,85	16,654	25/03/2032	
51,80	3108	207 564	86 818 645,24	34 584	601 994	0,345	200,19	16,683	04/04/2032	
51,90	3114	207 711	87 026 356,24	34 606	601 994	0,345	200,54	16,711	15/04/2032	
<b>52,00</b>	<b>3120</b>	<b>207 829</b>	<b>87 234 185,24</b>	<b>34 628</b>	<b>601 994</b>	<b>0,345</b>	<b>200,88</b>	<b>16,740</b>	<b>25/04/2032</b>	<b>2072834</b>
52,10	3126	207 911	87 442 096,24	34 645	601 994	0,345	201,23	16,769	06/05/2032	
52,20	3132	208 001	87 650 097,24	34 659	601 994	0,346	201,57	16,798	17/05/2032	
52,30	3138	208 110	87 858 207,24	34 676	601 994	0,346	201,92	16,827	27/05/2032	
52,40	3144	208 211	88 066 418,24	34 693	601 994	0,346	202,26	16,855	07/06/2032	
52,50	3150	208 297	88 274 715,24	34 709	601 994	0,346	202,61	16,884	17/06/2032	
52,60	3156	208 387	88 483 102,24	34 724	601 994	0,346	202,96	16,913	28/06/2032	
52,70	3162	208 516	88 691 618,24	34 742	601 994	0,346	203,30	16,942	08/07/2032	
52,80	3168	208 670	88 900 288,24	34 766	601 994	0,347	203,65	16,971	19/07/2032	
52,90	3174	208 800	89 109 088,24	34 789	601 994	0,347	204,00	17,000	29/07/2032	
<b>53,00</b>	<b>3180</b>	<b>208 891</b>	<b>89 317 979,24</b>	<b>34 808</b>	<b>601 994</b>	<b>0,347</b>	<b>204,34</b>	<b>17,029</b>	<b>09/08/2032</b>	<b>2083794</b>
53,10	3186	208 976	89 526 955,24	34 822	601 994	0,347	204,69	17,058	19/08/2032	
53,20	3192	209 071	89 736 026,24	34 837	601 994	0,347	205,04	17,086	30/08/2032	
53,30	3198	209 187	89 945 213,24	34 855	601 994	0,347	205,39	17,115	09/09/2032	
53,40	3204	209 307	90 154 520,24	34 875	601 994	0,348	205,73	17,144	20/09/2032	
53,50	3210	209 427	90 363 947,24	34 895	601 994	0,348	206,08	17,173	01/10/2032	
53,60	3216	209 556	90 573 503,24	34 915	601 994	0,348	206,43	17,202	11/10/2032	
53,70	3222	209 664	90 783 167,24	34 935	601 994	0,348	206,78	17,231	22/10/2032	
53,80	3228	209 764	90 992 931,24	34 952	601 994	0,348	207,13	17,260	01/11/2032	
53,90	3234	209 922	91 202 853,24	34 974	601 994	0,349	207,47	17,290	12/11/2032	
<b>54,00</b>	<b>3240</b>	<b>210 167</b>	<b>91 413 020,24</b>	<b>35 007</b>	<b>601 994</b>	<b>0,349</b>	<b>207,82</b>	<b>17,319</b>	<b>23/11/2032</b>	<b>2095041</b>
54,10	3246	210 436	91 623 456,24	35 050	601 994	0,350	208,17	17,348	03/12/2032	
54,20	3252	210 633	91 834 089,24	35 089	601 994	0,350	208,52	17,377	14/12/2032	
54,30	3258	210 746	92 044 835,24	35 115	601 994	0,350	208,87	17,406	25/12/2032	
54,40	3264	210 835	92 255 670,24	35 132	601 994	0,350	209,22	17,435	04/01/2033	
54,50	3270	210 961	92 466 631,24	35 150	601 994	0,350	209,57	17,464	15/01/2033	
54,60	3276	211 093	92 677 724,24	35 171	601 994	0,351	209,92	17,494	26/01/2033	
54,70	3282	211 155	92 888 879,24	35 187	601 994	0,351	210,28	17,523	05/02/2033	
54,80	3288	211 131	93 100 010,24	35 191	601 994	0,351	210,63	17,552	16/02/2033	
54,90	3294	211 077	93 311 087,24	35 184	601 994	0,351	210,98	17,581	27/02/2033	
<b>55,00</b>	<b>3300</b>	<b>211 057</b>	<b>93 522 144,24</b>	<b>35 178</b>	<b>601 994</b>	<b>0,351</b>	<b>211,33</b>	<b>17,611</b>	<b>09/03/2033</b>	<b>2109124</b>
55,10	3306	211 090	93 733 234,24	35 179	601 994	0,351	211,68	17,640	20/03/2033	
55,20	3312	211 133	93 944 367,24	35 185	601 994	0,351	212,03	17,669	31/03/2033	
55,30	3318	211 146	94 155 513,24	35 190	601 994	0,351	212,38	17,698	10/04/2033	
55,40	3324	211 152	94 366 665,24	35 192	601 994	0,351	212,73	17,727	21/04/2033	
55,50	3330	211 209	94 577 874,24	35 197	601 994	0,351	213,08	17,757	02/05/2033	
55,60	3336	211 358	94 789 232,24	35 214	601 994	0,351	213,43	17,786	12/05/2033	
55,70	3342	211 573	95 000 805,24	35 244	601 994	0,351	213,78	17,815	23/05/2033	
55,80	3348	211 746	95 212 551,24	35 277	601 994	0,352	214,14	17,845	03/06/2033	
55,90	3354	211 790	95 424 341,24	35 295	601 994	0,352	214,49	17,874	13/06/2033	



# Jones & Wagener

Engineering & Environmental Consultants

59 Bevan Road PO Box 1434 Rivonia 2128 South Africa  
 tel: 0027 11 519 0200 www.jaws.co.za email: post@jaws.co.za

Client:  
Job Des.

Eskom  
 Conceptual Modelling for Medupi Power station  
 Northern Ash Dump Facility

Job No:  
Sheet No:  
Made by:  
Date:

G145/00  
1  
SL  
23/11/2017

<b>56,00</b>	<b>3360</b>	<b>211 741</b>	<b>95 636 082,24</b>	<b>35 294</b>	601 994	<b>0,352</b>	<b>214,84</b>	<b>17,903</b>	<b>24/06/2033</b>	<b>2113938</b>
56,10	3366	211 714	95 847 796,24	35 288	601 994	0,352	215,19	17,933	05/07/2033	
56,20	3372	211 796	96 059 592,24	35 293	601 994	0,352	215,54	17,962	15/07/2033	
56,30	3378	211 957	96 271 549,24	35 313	601 994	0,352	215,89	17,991	26/07/2033	
56,40	3384	212 120	96 483 669,24	35 340	601 994	0,352	216,25	18,021	06/08/2033	
56,50	3390	212 225	96 695 894,24	35 362	601 994	0,353	216,60	18,050	17/08/2033	
56,60	3396	212 250	96 908 144,24	35 373	601 994	0,353	216,95	18,079	27/08/2033	
56,70	3402	212 227	97 120 371,24	35 373	601 994	0,353	217,30	18,109	07/09/2033	
56,80	3408	212 240	97 332 611,24	35 372	601 994	0,353	217,66	18,138	18/09/2033	
56,90	3414	212 341	97 544 952,24	35 382	601 994	0,353	218,01	18,167	28/09/2033	
<b>57,00</b>	<b>3420</b>	<b>212 470</b>	<b>97 757 422,24</b>	<b>35 401</b>	601 994	<b>0,353</b>	<b>218,36</b>	<b>18,197</b>	<b>09/10/2033</b>	<b>2121340</b>
57,10	3426	212 538	97 969 960,24	35 417	601 994	0,353	218,72	18,226	20/10/2033	
57,20	3 432	212 551	98 182 511,24	35 424	601 994	0,353	219,07	18,256	31/10/2033	
57,30	3438	212 565	98 395 076,24	35 426	601 994	0,353	219,42	18,285	10/11/2033	
57,40	3444	211 658	98 606 734,24	35 352	601 994	0,352	219,77	18,314	21/11/2033	
57,50	3450	209 751	98 816 485,24	35 117	601 994	0,348	220,12	18,343	02/12/2033	
57,60	3456	207 733	99 024 218,24	34 790	601 994	0,345	220,47	18,372	12/12/2033	
57,70	3462	205 660	99 229 878,24	34 449	601 994	0,342	220,81	18,401	23/12/2033	
57,80	3468	203 541	99 433 419,24	34 100	601 994	0,338	221,15	18,429	02/01/2034	
57,90	3474	201 349	99 634 768,24	33 741	601 994	0,334	221,48	18,457	12/01/2034	
<b>58,00</b>	<b>3480</b>	<b>199 021</b>	<b>99 833 789,24</b>	<b>33 364</b>	601 994	<b>0,331</b>	<b>221,81</b>	<b>18,484</b>	<b>22/01/2034</b>	<b>2076367</b>
58,10	3486	196 545	100 030 334,24	32 964	601 994	0,326	222,14	18,512	01/02/2034	
58,20	3492	193 945	100 224 279,24	32 541	601 994	0,322	222,46	18,538	11/02/2034	
58,30	3498	191 241	100 415 520,24	32 099	601 994	0,318	222,78	18,565	20/02/2034	
58,40	3504	188 358	100 603 878,24	31 633	601 994	0,313	223,09	18,591	02/03/2034	
58,50	3510	185 327	100 789 205,24	31 140	601 994	0,308	223,40	18,617	11/03/2034	
58,60	3516	182 267	100 971 472,24	30 633	601 994	0,303	223,70	18,642	21/03/2034	
58,70	3522	179 168	101 150 640,24	30 120	601 994	0,298	224,00	18,667	30/03/2034	
58,80	3528	175 996	101 326 636,24	29 597	601 994	0,292	224,29	18,691	08/04/2034	
58,90	3534	172 754	101 499 390,24	29 063	601 994	0,287	224,58	18,715	16/04/2034	
<b>59,00</b>	<b>3540</b>	<b>169 446</b>	<b>101 668 836,24</b>	<b>28 517</b>	601 994	<b>0,281</b>	<b>224,86</b>	<b>18,738</b>	<b>25/04/2034</b>	<b>1835047</b>
toe	3810	12	105 342 862,24	26	601 994	0,000	230,96	19,247	27/10/2034	3674026

### Southern stacker

36,00	2160		57 018 067,08		368 964	0,000	146,21	12,184	04/10/2027	
37,00	2220	1 695 509		28 258	368 964	4,595	150,80	12,567	20/02/2028	
38,00	2280	1 695 509		28 258	368 964	4,595	155,40	12,950	09/07/2028	
39,00	2340	1 695 509		28 258	368 964	4,595	159,99	13,333	26/11/2028	
40,00	2400	1 695 509		28 258	368 964	4,595	164,59	13,716	15/04/2029	
41,00	2460	1 695 509		28 258	368 964	4,595	169,19	14,099	02/09/2029	
42,00	2520	1 695 509		28 258	368 964	4,595	173,78	14,482	19/01/2030	
43,00	2580	1 695 509		28 258	368 964	4,595	178,38	14,865	08/06/2030	
44,00	2640	1 695 509		28 258	368 964	4,595	182,97	15,248	26/10/2030	
45,00	2700	1 695 509		28 258	368 964	4,595	187,57	15,631	15/03/2031	
46,00	2760	1 695 509		28 258	368 964	4,595	192,16	16,013	01/08/2031	
toe	3810	14 206 777			368 964	38,504	230,67	19,222	16/10/2034	

**ESKOM HOLDINGS SOC LIMITED**

MEDUPI POWER STATION  
NORTHERN ASH & GYPSUM DISPOSAL FACILITY  
CONCEPT DESIGN REPORT

Report: JW158/17/G145 – Rev 1

## **APPENDIX D**

# **LIFE CYCLE COST ESTIMATE**



# Jones & Wagener

Engineering & Environmental Consultants  
 59 Bevan Road PO Box 1434 Rivonia 2128 South Africa  
 tel:0027 11 519 0200 www.jaws.co.za email:post@jaws.co.za

Client:	<u>Eskom</u>	Job No:	<u>G145</u>
Job Des.:	<u>Conceptual Modelling for Medupi Power station</u>	Sheet No:	<u>1</u>
	<u>Northern ash dump</u>	Made by:	<u>SL</u>
		Date:	<u>23/11/2017</u>

## Model Information

<b>North</b>	<b>Volume</b>	194 000 000,00 m <sup>3</sup>			
	<b>Final elevation</b>	983,75 m.a.s.l			
	<b>Final Height</b>	72 m			
	<b>Life</b>	19,2 years			
	<b>No. of Shifts</b>	59			
	<b>Shift length</b>			<b>No. of Shifts in group</b>	
	Northern stacker			59	
	Southern stacker (parallel)			36	
	Southern stacker (radial)			10	46
	<b>Extendable length</b>				
	Initial	476 m	Ongoing		3540 m
	<b>Plan area</b>				
	Approach area (shift 4 to 20)	676 000 m <sup>2</sup>			
	Top of NADF (shift 21 to end)	1 180 000 m <sup>2</sup>			
	<b>Sloped areas</b>				
	Approach area (shift 4 to 20)	442 000 m <sup>2</sup>			
	Front Stack - Normal SS area	1 484 000 m <sup>2</sup>			
	Back Stack - Normal SS area	249 000 m <sup>2</sup>			
	Final area	265 000 m <sup>2</sup>			
(shift 21 to end)	Sub Total	1 998 000 m <sup>2</sup>			
(shift 4 to 20)	Front Stack - Extendable SS area	122 000 m <sup>2</sup>			
(shift 21 to end)	Front Stack - Extendable SS area	239 000 m <sup>2</sup>			
	Total area	4 657 000 m <sup>2</sup>			
	<b>Final NPV</b>	<b>R</b>	<b>1 186 059 338,63</b>		

<b>Lining cost</b>	4 - 8 year area	959 550 m <sup>2</sup>	
Class C liner	8 - 12 year area	1 045 892 m <sup>2</sup>	
R400/m2	12 - 16 year area	214 624 m <sup>2</sup>	
	Dam 3	103 765 m <sup>2</sup>	4 - 8 year
	Dam 3B	21 678 m <sup>2</sup>	12 - 16 year

<b>Rehab (post power station operations)</b>				Shift at which rehab takes place
R/m <sup>3</sup> 100	Dam D1	18 300 m <sup>3</sup>		56
	Dam D2	48 700 m <sup>3</sup>		56
	Dam D2B	45 000 m <sup>3</sup>		56
	PCD D4	69 000 m <sup>3</sup>		end
	PCD D5	30 540 m <sup>3</sup>		end
	Dam D3	260 000 m <sup>3</sup>		57
	Dam D3B	55 000 m <sup>3</sup>		58
	PCD D6	138 600 m <sup>3</sup>		59
	PCD D7	151 700 m <sup>3</sup>		59
	PCD D8	151 700 m <sup>3</sup>		59
R/m 150	Storm water canals	2 435 m	Dam D1 & D2	56
		1 226 m	Dam D2B	56
		1 065 m	Dam D3	57
		1 464 m	Dam D3B	58
		1 095 m	PCD D5	end
		962 m	PCD D4	end
		738 m	PCD D6, D7 & D8	59



**Jones & Wagener** Client:  
 Engineering & Environmental Consultants Job Des.  
 59 Bevan Road PO Box 1434 Rivonia 2128 South Africa  
 tel:027 11 519 0200 www.joneswagener.co.za email:pen@joneswagener.co.za

Eskom  
 Conceptual modelling for Medupi Power station  
 Northern ash dump

Job No: G145  
 Sheet No: 1  
 Made by: SL  
 Date: 23/11/2017

**Northern Dump**

NPV Assumptions  
 Discount Rate 8,4% (Eskom real rate)

Shift No.	CHAIN	Life	Date	Northern Extendable conveyor	Southern Extendable conveyor	Northern Shift Price	Southern Shift Price	Southern Load & Haul	Slope rehab	Slope rehab	Plan Area rehab	Lining and Rehab costs	Total	NPV
m	Years			R 80 600	R 80 600				Normal (R54/m <sup>2</sup> )	Extendable SS (R90/m <sup>2</sup> )	(R36/m <sup>2</sup> )			
<b>Northern and Southern Stackers combined</b>														
1	0	0,50	01/08/2015			R 2 121 242,85	R 2 121 242,85						R 4 242 485,70	R 4 242 485,70
2	66	0,20	12/10/2015	R 5 319 600,00	R 5 319 600,00	R 2 121 242,85	R 2 121 242,85						R 14 881 685,70	R 14 881 685,70
3	132	0,68	03/04/2016	R 5 319 600,00	R 5 319 600,00	R 2 121 242,85	R 2 121 242,85						R 14 881 685,70	R 14 881 685,70
4	198	1,04	16/08/2016	R 5 319 600,00	R 5 319 600,00	R 2 121 242,85	R 2 121 242,85						R 17 079 877,65	R 17 079 877,65
5	264	1,35	05/12/2016	R 5 319 600,00	R 5 319 600,00	R 2 121 242,85	R 2 121 242,85		R 1 491 750,00	R 686 250,00	R 1 521 000,00		R 18 580 685,70	R 18 580 685,70
6	330	1,65	25/03/2017	R 5 319 600,00	R 5 319 600,00	R 2 121 242,85	R 2 121 242,85		R 1 491 750,00	R 686 250,00	R 1 521 000,00		R 18 580 685,70	R 18 580 685,70
7	396	1,95	12/07/2017	R 5 319 600,00	R 5 319 600,00	R 2 121 242,85	R 2 121 242,85		R 1 491 750,00	R 686 250,00	R 1 521 000,00		R 18 580 685,70	R 18 580 685,70
8	462	2,23	24/10/2017	R 5 319 600,00	R 5 319 600,00	R 2 121 242,85	R 2 121 242,85		R 1 491 750,00	R 686 250,00	R 1 521 000,00		R 18 580 685,70	R 18 580 685,70
9	528	2,54	11/02/2018	R 5 319 600,00	R 5 319 600,00	R 2 121 242,85	R 2 121 242,85		R 1 491 750,00	R 686 250,00	R 1 521 000,00	R 425 326 000,00	R 443 906 685,70	R 361 769 793,47
10	594	2,82	27/05/2018	R 5 319 600,00	R 5 319 600,00	R 2 121 242,85	R 2 121 242,85		R 1 491 750,00	R 686 250,00	R 1 521 000,00		R 14 796 899,27	R 14 796 899,27
11	660	3,14	20/09/2018	R 5 319 600,00	R 5 319 600,00	R 2 121 242,85	R 2 121 242,85		R 1 491 750,00	R 686 250,00	R 1 521 000,00		R 18 580 685,70	R 18 580 685,70
12	726	3,46	13/01/2019	R 4 836 000,00	R 4 836 000,00	R 2 121 242,85	R 2 121 242,85		R 1 491 750,00	R 686 250,00	R 1 521 000,00		R 17 613 485,70	R 17 613 485,70
13	792	3,80	17/05/2019	R 4 836 000,00	R 4 836 000,00	R 2 121 242,85	R 2 121 242,85		R 1 491 750,00	R 686 250,00	R 1 521 000,00		R 17 613 485,70	R 17 613 485,70
14	858	4,16	25/09/2019	R 4 836 000,00	R 4 836 000,00	R 2 121 242,85	R 2 121 242,85		R 1 491 750,00	R 686 250,00	R 1 521 000,00		R 17 613 485,70	R 17 613 485,70
15	924	4,53	10/02/2020	R 4 836 000,00	R 4 836 000,00	R 2 121 242,85	R 2 121 242,85		R 1 491 750,00	R 686 250,00	R 1 521 000,00		R 17 613 485,70	R 17 613 485,70
16	990	4,93	04/07/2020	R 4 836 000,00	R 4 836 000,00	R 2 121 242,85	R 2 121 242,85		R 1 491 750,00	R 686 250,00	R 1 521 000,00		R 17 613 485,70	R 17 613 485,70
17	1020	5,34	02/12/2020	R 4 836 000,00	R 4 836 000,00	R 2 121 242,85	R 2 121 242,85		R 1 491 750,00	R 686 250,00	R 1 521 000,00		R 17 613 485,70	R 17 613 485,70
18	1080	5,77	05/05/2021	R 4 836 000,00	R 4 836 000,00	R 2 121 242,85	R 2 121 242,85		R 1 491 750,00	R 686 250,00	R 1 521 000,00		R 17 613 485,70	R 17 613 485,70
19	1140	6,18	04/10/2021	R 4 836 000,00	R 4 836 000,00	R 2 121 242,85	R 2 121 242,85		R 1 491 750,00	R 686 250,00	R 1 521 000,00		R 17 613 485,70	R 17 613 485,70
20	1200	6,58	27/02/2022	R 4 836 000,00	R 4 836 000,00	R 2 121 242,85	R 2 121 242,85		R 1 491 750,00	R 686 250,00	R 1 521 000,00		R 17 613 485,70	R 17 613 485,70
21	1260	6,97	19/07/2022	R 4 836 000,00	R 4 836 000,00	R 2 121 242,85	R 2 121 242,85		R 2 697 300,00	R 551 538,46	R 1 089 230,77	R 418 356 800,00	R 436 609 354,93	R 248 809 102,55
22	1320	7,35	03/01/2023	R 4 836 000,00	R 4 836 000,00	R 2 121 242,85	R 2 121 242,85		R 2 697 300,00	R 551 538,46	R 1 089 230,77		R 18 252 554,93	R 10 092 779,51
23	1380	7,71	15/04/2023	R 4 836 000,00	R 4 836 000,00	R 2 121 242,85	R 2 121 242,85		R 2 697 300,00	R 551 538,46	R 1 089 230,77		R 18 252 554,93	R 9 800 472,25
24	1440	8,07	22/08/2023	R 4 836 000,00	R 4 836 000,00	R 2 121 242,85	R 2 121 242,85		R 2 697 300,00	R 551 538,46	R 1 089 230,77		R 18 252 554,93	R 9 523 526,10
25	1500	8,41	26/12/2023	R 4 836 000,00	R 4 836 000,00	R 2 121 242,85	R 2 121 242,85		R 2 697 300,00	R 551 538,46	R 1 089 230,77		R 18 252 554,93	R 9 262 637,16
26	1560	8,74	26/04/2024	R 4 836 000,00	R 4 836 000,00	R 2 121 242,85	R 2 121 242,85		R 2 697 300,00	R 551 538,46	R 1 089 230,77		R 18 252 554,93	R 9 016 129,69
27	1620	9,08	26/08/2024	R 4 836 000,00	R 4 836 000,00	R 2 121 242,85	R 2 121 242,85		R 2 697 300,00	R 551 538,46	R 1 089 230,77		R 18 252 554,93	R 8 777 058,60
28	1680	9,41	26/12/2024	R 4 836 000,00	R 4 836 000,00	R 2 121 242,85	R 2 121 242,85		R 2 697 300,00	R 551 538,46	R 1 089 230,77		R 18 252 554,93	R 8 542 920,74
29	1740	9,75	23/04/2025	R 4 836 000,00	R 4 836 000,00	R 2 121 242,85	R 2 121 242,85		R 2 697 300,00	R 551 538,46	R 1 089 230,77		R 18 252 554,93	R 8 313 308,79
30	1800	10,09	31/08/2025	R 4 836 000,00	R 4 836 000,00	R 2 121 242,85	R 2 121 242,85		R 2 697 300,00	R 551 538,46	R 1 089 230,77		R 18 252 554,93	R 8 087 876,80
31	1860	10,43	03/01/2026	R 4 836 000,00	R 4 836 000,00	R 2 121 242,85	R 2 121 242,85		R 2 697 300,00	R 551 538,46	R 1 089 230,77		R 18 252 554,93	R 7 867 219,69
32	1920	10,78	09/05/2026	R 4 836 000,00	R 4 836 000,00	R 2 121 242,85	R 2 121 242,85		R 2 697 300,00	R 551 538,46	R 1 089 230,77		R 18 252 554,93	R 7 651 030,83
33	1980	11,13	13/09/2026	R 4 836 000,00	R 4 836 000,00	R 2 121 242,85	R 2 121 242,85		R 2 697 300,00	R 551 538,46	R 1 089 230,77		R 18 252 554,93	R 7 439 367,29
34	2040	11,48	19/01/2027	R 4 836 000,00	R 4 836 000,00	R 2 121 242,85	R 2 121 242,85		R 2 697 300,00	R 551 538,46	R 1 089 230,77	R 94 520 800,00	R 112 773 354,93	R 44 684 719,02
35	2100	11,83	27/05/2027	R 4 836 000,00	R 4 836 000,00	R 2 121 242,85	R 2 121 242,85		R 2 697 300,00	R 551 538,46	R 1 089 230,77		R 18 252 554,93	R 7 029 791,34
36	2160	12,18	04/10/2027	R 4 836 000,00	R 4 836 000,00	R 2 121 242,85	R 2 121 242,85		R 2 697 300,00	R 551 538,46	R 1 089 230,77		R 18 252 554,93	R 6 831 649,72
<b>Northern and South Stacker separately</b>														
37	2220	12,46	17/01/2028	R 4 836 000,00	R 4 836 000,00	R 2 121 242,85	R 1 484 870,00		R 2 697 300,00	R 551 538,46	R 1 089 230,77		R 12 780 182,08	R 4 676 691,67
38	2280	12,75	28/04/2028	R 4 836 000,00	R 4 836 000,00	R 2 121 242,85	R 1 484 870,00		R 2 697 300,00	R 551 538,46	R 1 089 230,77		R 12 780 182,08	R 4 571 638,11
39	2340	13,03	10/08/2028	R 4 836 000,00	R 4 836 000,00	R 2 121 242,85	R 1 484 870,00		R 2 697 300,00	R 551 538,46	R 1 089 230,77		R 12 780 182,08	R 4 468 344,11
40	2400	13,31	22/11/2028	R 4 836 000,00	R 4 836 000,00	R 2 121 242,85	R 1 484 870,00		R 2 697 300,00	R 551 538,46	R 1 089 230,77		R 12 780 182,08	R 4 366 776,63
41	2460	13,60	06/03/2029	R 4 836 000,00	R 4 836 000,00	R 2 121 242,85	R 1 484 870,00		R 2 697 300,00	R 551 538,46	R 1 089 230,77		R 12 780 182,08	R 4 267 458,08
42	2520	13,98	18/06/2029	R 4 836 000,00	R 4 836 000,00	R 2 121 242,85	R 1 484 870,00		R 2 697 300,00	R 551 538,46	R 1 089 230,77		R 12 780 182,08	R 4 170 591,04
43	2580	14,17	30/09/2029	R 4 836 000,00	R 4 836 000,00	R 2 121 242,85	R 1 484 870,00		R 2 697 300,00	R 551 538,46	R 1 089 230,77		R 12 780 182,08	R 4 075 961,50
44	2640	14,45	12/01/2030	R 4 836 000,00	R 4 836 000,00	R 2 121 242,85	R 1 484 870,00		R 2 697 300,00	R 551 538,46	R 1 089 230,77		R 12 780 182,08	R 3 983 239,19
45	2700	14,74	26/04/2030	R 4 836 000,00	R 4 836 000,00	R 2 121 242,85	R 1 484 870,00		R 2 697 300,00	R 551 538,46	R 1 089 230,77		R 12 780 182,08	R 3 892 570,46
46	2760	15,02	08/08/2030	R 4 836 000,00	R 4 836 000,00	R 2 121 242,85	R 1 484 870,00		R 2 697 300,00	R 551 538,46	R 1 089 230,77		R 12 780 182,08	R 3 803 981,88
47	2820	15,31	21/11/2030	R 4 836 000,00	R 4 836 000,00	R 2 121 242,85	R 1 484 870,00	R 16 419 506,07	R 2 697 300,00	R 551 538,46	R 1 089 230,77		R 12 780 182,08	R 3 714 818,15
48	2880	15,60	05/03/2031	R 4 836 000,00	R 4 836 000,00	R 2 121 242,85	R 1 484 870,00	R 16 394 364,42	R 2 697 300,00	R 551 538,46	R 1 089 230,77		R 12 780 182,08	R 3 629 563,78
49	2940	15,88	18/06/2031	R 4 836 000,00	R 4 836 000,00	R 2 121 242,85	R 1 484 870,00	R 16 351 962,16	R 2 697 300,00	R 551 538,46	R 1 089 230,77		R 12 780 182,08	R 3 549 841,80
50	3000	16,17	03/09/2031	R 4 836 000,00	R 4 836 000,00	R 2 121 242,85	R 1 484 870,00	R 16 315 173,96	R 2 697 300,00	R 551 538,46	R 1 089 230,77		R 12 780 182,08	R 3 474 245,93
51	3060	16,45	12/01/2032	R 4 836 000,00	R 4 836 000,00	R 2 121 242,85								



Client: Eskom  
Job Des: Conceptual modelling for Medupi Power station  
Northern ash dump

Job No: G145  
Sheet No: 1  
Made by: SL  
Date: 23/11/2017

**NPV Assumptions**

Discount Rate 8,4%  
Discount Date 31/10/2017

Ash dry density 800 kg/m<sup>3</sup>

Volume to be trucked 14 206 776,93 m3  
Date Started 08/08/2030  
Date Ended 27/10/2034  
Days 1542  
Total haul hours per shift 12336  
Trucking efficiency 80% (Assumption)  
Number of 8 hour shifts 1 per day (Assumption)  
Size of truck 30 ton  
38 m3  
Number of loads per shift 473 560  
Number of loads per hour 38,39 (40 loads per hour)  
Average Round trip duration 26 minutes Top Stacker Shiftable length approximately 1640m  
Number of trucks per hour 17,00 Average trip  
Number of loaders per day 3 Load 7,5 min  
Volume per day 9 213 m3 Travel 9,84 min  
Total Rate per day Haul R 133 280,00 Deposit 5,00 min  
Total Rate per day Load R 23 640,00 Wait in line 3 min  
Total 25,34 min

**Eskom / Roshcon Provided Rates**

Articulated truck - haul R 980,00  
Operator Incl  
Diesel Incl  
Total per hour rate R 980,00  
  
Front end loader R 985,00  
Operator Incl  
Diesel Incl  
Total per hour rate R 985,00  
  
Loader  
Service per truck 7,50 min  
No. of trucks 8,00 Trucks per hour

Ash	Days	Life	Date	Haul		load		Total	NPV
Volume		Years		R	133 280,00	R	23 640,00		
964 037	104,64	15,31	21/11/2030	R	13 945 907,27	R	2 473 598,80	R 16 419 506,07	R 4 775 507,03
962 561	104,48	15,60	05/03/2031	R	13 924 553,21	R	2 469 811,21	R 16 394 364,42	R 4 659 371,75
960 071	104,21	15,88	18/06/2031	R	13 888 538,85	R	2 463 423,31	R 16 351 962,16	R 4 541 527,64
957 911	103,97	16,17	30/09/2031	R	13 857 292,29	R	2 457 881,07	R 16 315 173,36	R 4 428 387,24
959 832	104,18	16,45	12/01/2032	R	13 885 070,75	R	2 462 808,17	R 16 347 878,92	R 4 336 278,01
964 930	104,73	16,74	25/04/2032	R	13 958 823,42	R	2 475 889,75	R 16 434 713,16	R 4 259 577,61
970 032	105,29	17,03	09/08/2032	R	14 032 629,96	R	2 488 980,88	R 16 521 610,84	R 4 183 621,15
975 267	105,86	17,32	23/11/2032	R	14 108 369,20	R	2 502 414,83	R 16 610 784,03	R 4 108 952,41
981 823	106,57	17,61	09/03/2033	R	14 203 206,57	R	2 519 236,22	R 16 722 442,78	R 4 040 298,26
984 064	106,81	17,90	24/06/2033	R	14 235 624,88	R	2 524 986,29	R 16 760 611,16	R 3 955 058,79
987 510	107,18	18,20	09/10/2033	R	14 285 471,23	R	2 533 827,58	R 16 819 298,81	R 3 876 006,27
966 574	104,91	18,48	22/01/2034	R	13 982 615,25	R	2 480 109,73	R 16 462 724,98	R 3 706 891,52
854 237	92,72	18,74	25/04/2034	R	12 357 524,55	R	2 191 865,85	R 14 549 390,39	R 3 209 627,97
1 710 304	185,64	19,25	27/10/2034	R	24 741 527,86	R	4 388 428,26	R 29 129 956,12	R 6 167 854,94
								R 241 840 417,20	
								<b>FINAL NPV</b>	<b>R 60 248 960,59</b>

**ESKOM HOLDINGS SOC LIMITED**

MEDUPI POWER STATION  
NORTHERN ASH & GYPSUM DISPOSAL FACILITY  
CONCEPT DESIGN REPORT

Report: JW158/17/G145 – Rev 1

## **APPENDIX E**

### **MINUTES FROM DWS MEETING**





# Jones & Wagener

Engineering & Environmental Consultants  
59 Bevan Road PO Box 1434 Rivonia 2128 South Africa  
tel: 00 27 11 519 0200 www.jaws.co.za email: post@jaws.co.za

**50**  
YEARS EST. 1966

**ESKOM**  
**MEDUPI POWER STATION**  
**NORTHERN ASH DISPOSAL FACILITY**  
**CONCEPT DESIGN**

Distribution Date: 12 October, 2017  
Job No: **G145**  
Our Ref: g145\_min\_r1\_sljscn  
nn\_dwsmeeting\_20  
171009

## **MINUTES OF THE DESIGN APPROVAL MEETING**

Held at **DWS Pretoria** on **9 October 2017**

Next meeting: N/A

### **PRESENT:**

<b><u>NAME:</u></b>	<b><u>COMPANY:</u></b>	<b><u>CELL/LANDLINE</u></b>	<b><u>EMAIL</u></b>
Kelvin Legge (KL)	DWS	012 336 8677	<a href="mailto:leggek@dwa.gov.za">leggek@dwa.gov.za</a>
Michelle Parker (MP)	DWS	012 336 8252	<a href="mailto:parker@dwa.gov.za">parker@dwa.gov.za</a>
Karl Bester (KB)	DWS	012 336 8300	<a href="mailto:besterk2@dws.gov.za">besterk2@dws.gov.za</a>
Tumi Seake (TM)	DWS	012 336 7061	<a href="mailto:seakeb@dwa.gov.za">seakeb@dwa.gov.za</a>
Asa Mbewu (AM)	DWS	012 336 6884	<a href="mailto:Mbewua@dws.gov.za">Mbewua@dws.gov.za</a>
Tshiruruvhela Takalani (TT)	DWS	071 886 4185	<a href="mailto:tshiruruvhelat@dws.gov.za">tshiruruvhelat@dws.gov.za</a>
Jonathan Shamrock (JS)	Jones & Wagener	011 519 0200	<a href="mailto:shamrock@jaws.co.za">shamrock@jaws.co.za</a>
Silke Louw (SL)	Jones & Wagener	011 519 0200	<a href="mailto:silke@jaws.co.za">silke@jaws.co.za</a>
Kerissa Munsamy (KM)	Eskom	076 184 5640	<a href="mailto:munsamyk@eskom.co.za">munsamyk@eskom.co.za</a>
Nireshni Naidoo (NN)	Eskom	083 792 4460	<a href="mailto:naidoonr@eskom.co.za">naidoonr@eskom.co.za</a>
Muhammad Bagus (MB)	Eskom	084 761 1645	<a href="mailto:bagusm@eskom.co.za">bagusm@eskom.co.za</a>
Theuns Blom (TB)	Eskom	076 184 5640	<a href="mailto:blomtf@eskom.co.za">blomtf@eskom.co.za</a>
Felicia Sono (FS)	Eskom	083 297 4318	<a href="mailto:felicia.sono@eskom.co.za">felicia.sono@eskom.co.za</a>
Tobile Bokwe (TB)	Eskom	083 297 4318	<a href="mailto:bokwett@eskom.co.za">bokwett@eskom.co.za</a>

### **APOLOGIES:**

<b><u>NAME:</u></b>	<b><u>COMPANY:</u></b>	<b><u>CELL/LANDLINE</u></b>	<b><u>EMAIL</u></b>
Charl Cilliers	Jones & Wagener	011 519 0200	<a href="mailto:cilliers@jaws.co.za">cilliers@jaws.co.za</a>

### **DISTRIBUTION:**

<b><u>NAME:</u></b>	<b><u>COMPANY:</u></b>	<b><u>CELL</u></b>	<b><u>EMAIL</u></b>
Kelvin Legge (KL)	DWS	012 336 8677	<a href="mailto:leggek@dwa.gov.za">leggek@dwa.gov.za</a>
Michelle Parker (MP)	DWS	012 336 8252	<a href="mailto:parker@dwa.gov.za">parker@dwa.gov.za</a>
Karl Bester (KB)	DWS	012 336 8300	<a href="mailto:besterk2@dws.gov.za">besterk2@dws.gov.za</a>
Tumi Seake (TM)	DWS	012 336 7061	<a href="mailto:seakeb@dwa.gov.za">seakeb@dwa.gov.za</a>
Asa Mbewu (AM)	DWS	012 336 6884	<a href="mailto:Mbewua@dws.gov.za">Mbewua@dws.gov.za</a>
Tshiruruvhela Takalani (TT)	DWS	071 886 4185	<a href="mailto:tshiruruvhelat@dws.gov.za">tshiruruvhelat@dws.gov.za</a>
Jonathan Shamrock (JS)	Jones & Wagener	011 519 0200	<a href="mailto:shamrock@jaws.co.za">shamrock@jaws.co.za</a>
Charl Cilliers	Jones & Wagener	011 519 0200	<a href="mailto:cilliers@jaws.co.za">cilliers@jaws.co.za</a>
Silke Louw (SL)	Jones & Wagener	011 519 0200	<a href="mailto:silke@jaws.co.za">silke@jaws.co.za</a>
Kerissa Munsamy (KM)	Eskom	076 184 5640	<a href="mailto:munsamyk@eskom.co.za">munsamyk@eskom.co.za</a>
Nireshni Naidoo (NN)	Eskom	083 792 4460	<a href="mailto:naidoonr@eskom.co.za">naidoonr@eskom.co.za</a>
Muhammad Bagus (MB)	Eskom	084 761 1645	<a href="mailto:bagusm@eskom.co.za">bagusm@eskom.co.za</a>
Theuns Blom (TB)	Eskom	076 184 5640	<a href="mailto:munsamyk@eskom.co.za">munsamyk@eskom.co.za</a>
Felicia Sono (FS)	Eskom	083 297 4318	<a href="mailto:felicia.sono@eskom.co.za">felicia.sono@eskom.co.za</a>
Tobile Bokwe (TB)	Eskom	083 297 4318	<a href="mailto:bokwett@eskom.co.za">bokwett@eskom.co.za</a>

**MINUTES OF MEETING**

	<b>Action</b>	<b>DATE</b>
<b>1. INTRODUCTION</b>		
1.1	KL welcomed all to the meeting. SL thanked the Department of Water and Sanitation (DWS) civil design division for taking the time to attend the meeting.	Note
<b>2. ATTENDANCE</b>		
2.1	Attendance registers were circulated – see <b>Appendix A</b> . JS offered apologies for Charl Cilliers the Project Manager from J&W as he is on paternity leave.	Note
<b>3. PROJECT PRESENTATION</b>		
3.1	SL presented slides on the background of the concept design of the northern ash disposal facility. The presentation is attached as <b>Appendix B</b> of these minutes.	Note
<b>4. DISCUSSION</b>		
4.1	KL asked what the slope on the base of the facility would be and SL indicated that the natural ground slope would be utilised which is 1:135 (0.75%). KL noted that this is very flat but seeing as it is a Class C liner perhaps the thickness of the leachate collection layer can be increased or more frequently spaced drains could be implemented to assist with drainage of the barrier.	
4.2	KL enquired as to whether the durability of the coarse ash drainage layer has been tested under the equivalent final load. SL stated that since this is still in the concept design phase, only basic tests such foundation indicator and permeability testing has been undertaken. KL recommended that the Los Angeles abrasion test should be conducted. Similarly, KL suggested that the filter compatibility of sieved coarse ash drainage layer with the deposited ash under load be investigated.	
4.3	Regarding the use of BES instead of GCL, KL confirmed that a polymer enriched GCL is not recommended under high load as the polymer can extrude out. KL also stated that cation exchange is less of an issue with GCL which compresses under load and this is not necessarily the case with BES where to an extent the load would be carried by the sand matrix. JS responded that GCL introduces a weak interface under the liner and the barrier package is thin and vulnerable with a GCL composite.	
4.4	KL suggested considering the performance and cost benefits of incorporating a 2mm thick HDPE geomembrane instead of the two layers of 150 mm BES and 1.5mm thick HDPE. JS explained that as per the Class C lining standard a composite system is required and a single geomembrane will not be pursued due to the increased expected 4 to 5 order of magnitude increased leakage rates with geomembrane only lined facilities.	
4.5	TB confirmed that the issue of disposal of gypsum and ash together has been resolved and will be acceptable.	

	Action	DATE
<p>4.6 Furthermore, KL posed the question as to how the disposal of the ash and gypsum together:</p> <ul style="list-style-type: none"> <li>• Will change leachate? Will it form a precipitate and how will this affect the permeability of the coarse ash drainage layer?</li> <li>• Will it affect the permeability of the BES?</li> <li>• Will it affect the durability of the geomembrane?</li> </ul> <p>KL advised that testing with geomembrane coupons in 85°C ash/gypsum leachate could provide some answers to high pH and high salts impact on the liner, along with long term permeability testing of the BES with leachate which will be required.</p>		
<p>4.7 Regarding the geomembrane specification, KL will not support a specified asperity height. SL explained that if a product with a lower asperity height is suggested it will be accepted if it meets the interface shear performance specification. Besides other specified deviations, the geomembrane will meet GRI GM 13 standards, including density.</p>		
<p>4.8 KL stated that the engineering principles of the design are broadly acceptable, although technical issues regarding the combined ash and gypsum leachate, and its impacts on the barrier system, need to be further investigated. At this stage, without a technical address of the chemical and loading performance of the barrier system, KL cannot concur if the final design will be acceptable or not.</p>		
<p><b>5. Closure</b></p> <p>KL indicated that there were no further comments or questions. The meeting was closed at 9:00am.</p>		

Next meeting: N/A

Minuted by:

**Silke Louw**  
for Jones & Wagener

---

Document source: C:\Alljobs\G145\_Medupi\COR\G145\_MIN\_r1\_sljscn\_DWSmeeting\_20171009.docx  
Document template: corMinutes\_17r0